

FLUKE®

1623

Earth/Ground Tester

Users Manual

January 2006

© 2006 Fluke Corporation, All rights reserved. Printed in USA
All product names are trademarks of their respective companies.

LIMITED WARRANTY AND LIMITATION OF LIABILITY

Each Fluke product is warranted to be free from defects in material and workmanship under normal use and service. The warranty period is two years and begins on the date of shipment. Parts, product repairs, and services are warranted for 90 days. This warranty extends only to the original buyer or end-user customer of a Fluke authorized reseller, and does not apply to fuses, disposable batteries, or to any product which, in Fluke's opinion, has been misused, altered, neglected, contaminated, or damaged by accident or abnormal conditions of operation or handling. Fluke warrants that software will operate substantially in accordance with its functional specifications for 90 days and that it has been properly recorded on non-defective media. Fluke does not warrant that software will be error free or operate without interruption.

Fluke authorized resellers shall extend this warranty on new and unused products to end-user customers only but have no authority to extend a greater or different warranty on behalf of Fluke. Warranty support is available only if product is purchased through a Fluke authorized sales outlet or Buyer has paid the applicable international price. Fluke reserves the right to invoice Buyer for importation costs of repair/replacement parts when product purchased in one country is submitted for repair in another country.

Fluke's warranty obligation is limited, at Fluke's option, to refund of the purchase price, free of charge repair, or replacement of a defective product which is returned to a Fluke authorized service center within the warranty period.

To obtain warranty service, contact your nearest Fluke authorized service center to obtain return authorization information, then send the product to that service center, with a description of the difficulty, postage and insurance prepaid (FOB Destination). Fluke assumes no risk for damage in transit. Following warranty repair, the product will be returned to Buyer, transportation prepaid (FOB Destination). If Fluke determines that failure was caused by neglect, misuse, contamination, alteration, accident, or abnormal condition of operation or handling, including overvoltage failures caused by use outside the product's specified rating, or normal wear and tear of mechanical components, Fluke will provide an estimate of repair costs and obtain authorization before commencing the work. Following repair, the product will be returned to the Buyer transportation prepaid and the Buyer will be billed for the repair and return transportation charges (FOB Shipping Point).

THIS WARRANTY IS BUYER'S SOLE AND EXCLUSIVE REMEDY AND IS IN LIEU OF ALL OTHER WARRANTIES, EXPRESS OR IMPLIED, INCLUDING BUT NOT LIMITED TO ANY IMPLIED WARRANTY OF MERCHANTABILITY OR FITNESS FOR A PARTICULAR PURPOSE. FLUKE SHALL NOT BE LIABLE FOR ANY SPECIAL, INDIRECT, INCIDENTAL OR CONSEQUENTIAL DAMAGES OR LOSSES, INCLUDING LOSS OF DATA, ARISING FROM ANY CAUSE OR THEORY.

Since some countries or states do not allow limitation of the term of an implied warranty, or exclusion or limitation of incidental or consequential damages, the limitations and exclusions of this warranty may not apply to every buyer. If any provision of this Warranty is held invalid or unenforceable by a court or other decision-maker of competent jurisdiction, such holding will not affect the validity or enforceability of any other provision.

Fluke Corporation
P.O. Box 9090
Everett, WA 98206-9090
U.S.A.

Fluke Europe B.V.
P.O. Box 1186
5602 BD Eindhoven
The Netherlands

Table of Contents

Title	Page
Introduction	1
Unpacking.....	1
Packing.....	1
Safety Regulations	1
Features	2
Accessories.....	4
Carrying Case.....	4
Models and Accessories.....	5
Setup.....	6
Inserting Batteries.....	6
Operating Instructions.....	7
R _A 2-pole, 3-pole Measurements	7
R _A 4-pole Measurements	9
R _A 3-pole Selective Earth Resistance Measurement with Current Clamp.....	10
R _A 4-pole Selective Earth Resistance Measurement with Current Clamp.....	11
Stakeless Ground Loop Measurement.....	12
Troubleshooting.....	14
Specifications	16
Service	21
Storage.....	21

List of Tables

Table	Title	Page
1.	Features and Functions.....	3
2.	Models and Accessories	5
3.	Troubleshooting.....	14

List of Figures

Figure	Title	Page
1.	Features and Functions.....	3
2.	Inserting Batteries	6
3.	R _A 2-pole Measurement	8
4.	R _A 3-pole Measurement	8
5.	R _A 4-pole Measurements	9
6.	R _A 3-pole Selective Earth Resistance Measurement with Current Clamp	10
7.	R _A 4-pole Selective Earth Resistance Measurement with Current Clamp	11
8.	Stakeless Ground Loop Measurement	13
9.	Troubleshooting.....	15

Earth/Ground Tester

Introduction

This instrument has been manufactured complying with quality assurance system DIN ISO 9001. The compliance with the actual EMC-regulations is documented by the attached CE-sign.

Unpacking

Check delivery for damage during transport. Keep the packing material for later transport and check scope of delivery.

Packing

Use for shipping the original packing only.

Safety Regulations

This instrument is suited for measurements according to IEC 1024, ENV 61024, DIN VDE 0185 and ÖVE-E 49.

This measuring device is only to be installed and operated by qualified personnel and according to the technical data in compliance with the safety precautions and regulations set forth below. Additionally, the use of this equipment requires compliance with all legal and safety regulations pertaining to each specific application. Similar regulations apply to the use of accessories.

Operating electrical devices implies that parts of the device carry dangerous voltages. Disregarding warning notices may lead to serious physical injury and material damage.

It can be assumed that safe operation is no longer possible if the device

- shows visible damage,
- has been exposed to unfavourable conditions (e.g. storage beyond the permissible climatic limits without adaptation to the ambient climate, dewing etc.) or
- has been exposed to major strain during transport (e.g. been dropped from some height without visible external damage etc.).

No measurements must be performed on unprotected measuring circuits.

While a measurement is in progress no earth stake must be touched!

Qualified Personnel are persons familiar with the setting up, installation, starting off and operation of the device and possess a formal qualification required for such activities.

Features

- Earth/ground resistance measurements in different installations (e.g. high voltage pylons, buildings, electrical service grounding systems, mobile communication stations, HF transmitters etc.)
- Monitoring and planning of lightning protection systems
- Resistance measurements with earth electrodes; no separation

Refer to Figure 1 and Table 1 for a complete list of features and functions.

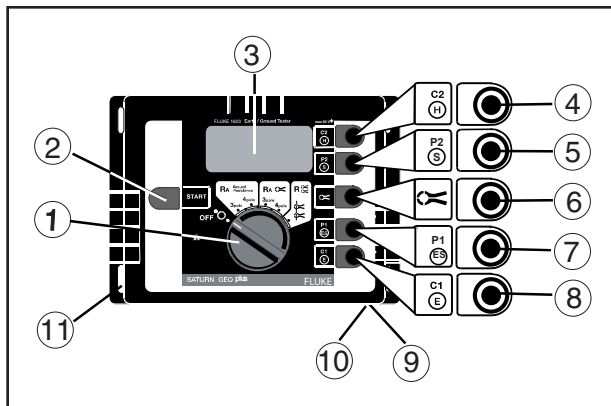

edv001.eps

Figure 1. Features and Functions

Table 1. Features and Functions

Item	Description
①	Rotary switch for selection of measurement functions and ON/OFF.
②	START button for starting the selected measurement function.
③	Liquid crystal display (LCD).
④	Connection "H" for auxiliary earth 4 mm Ø
⑤	Connection "S" for probe 4 mm Ø
⑥	Connection  for sensing current test clamp
⑦	Connection "ES" for earth electrode probe 4 mm Ø
⑧	Connection "E" for the earth/ground electrode to be measured 4 mm Ø
⑨	Battery compartment for 6 alkaline batteries (type AA, LR6) or NiCd
⑩	Batteries (bottom side of instrument)

Accessories

The following standard accessories were shipped with your Tester:

- 6 alkaline AA – type (LR6) batteries
- 2 measuring leads 1,5 m
- 1 connector cable (for RA 2-pole measurements)
- 2 alligator clips
- 1 Users Manual

Carrying Case

The part number for the carrying case for the 1623 Earth/Ground Tester and accessories such as the current probes is 2583565.

Models and Accessories

Table 2 lists the models and accessories.

Table 2. Models and Accessories

Description	Item/Part Number
Earth Ground Tester – Basic (Includes manual, 2 leads and 2 clips)	Fluke-1623
Earth Ground Tester - Fully Loaded (Includes manual, 2 leads and 2 clips, ES162P4, EI-1623)	Fluke-1623 Kit
Service Replacement Kit (Includes 2 Leads, 2 Clips)	Fluke-162x-7001
Stake Set for 3 Pole Measurement (Includes three stakes, one 25 m cable reel, one 50 m cable reel)	ES-162P3
Stake set for 4 Pole Measurement (Includes four stakes, two 25 m cable reels, one 50 m cable reel)	ES-162P4
Selective/Stakeless Clamp Set for 1623, Consists of EI-162X and EI- 162AC	EI-1623
Clip-on Current Transformer (sensing) with shielded cable set	EI-162X
Shielded Cable (Used w/EI-162X Clamp)	2630254
Clip-on Current Transformer (inducing)	EI-162AC
12.7 Inch (320mm) Split Core Transformer	EI-162BN
Earth Stake	2630222
Cable Reel w/25m Wire	2630231
Cable Reel w/50m Wire	2630246
1623 Users Manual	2560327

Setup

⚠ Warning

Please, read carefully the “safety regulations” before powering up the instrument. If you have problems see section “Troubleshooting”.

Inserting Batteries

Refer to Figure 2 and following these steps:

1. Switch off instrument.
2. Disconnect all test leads.
3. Open battery compartment.
4. Insert batteries. Close battery compartment.

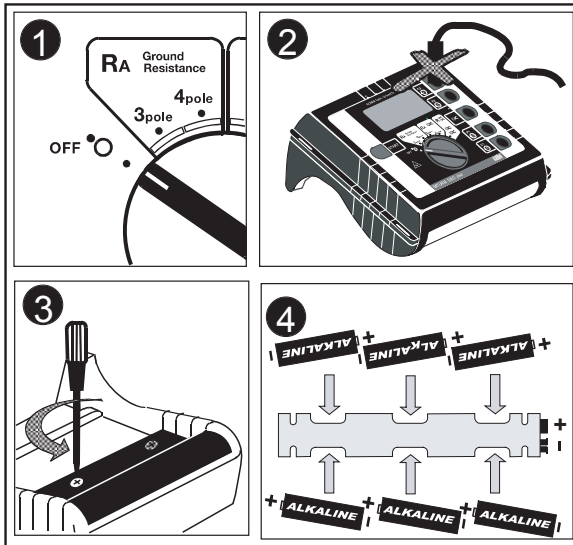

Figure 2. Inserting Batteries

edv002.eps

Operating Instructions

R_A 2-pole, 3-pole Measurements

To make 2-pole or dead-earth measurements, connect a jumper between terminals H/C2 and S/P2 with the supplied connector cable. Refer to Figures 3 and 4. Then follow steps 1 thru 4 except use only earth electrode and the auxiliary earth electrode with minimum distance between them of 20 m.

- ① Select function R_A 3-pole.

Display is as shown below.

- ② Connect test leads

Connect terminal E/C1 to the earth/ground system to be measured with the supplied test lead and clip (1.5 m). Place 2 ground stakes in earth/dirt. Minimum distance between earth electrode (E/C1), probe (S/P2), and auxiliary earth (H/C2) should be at least 20 m!

Connect the stakes with the 25 m and 50 m cable reels to H/C2 and S/P2 as shown below.

- ③ Press START.

The “active” symbol indicates that a measurement is in progress. For a continuous measurement keep START pressed.

- ④ The Symbol “✓” indicates a completed measurement. The result is kept on the display until a new measurement is started or the main switch is turned.

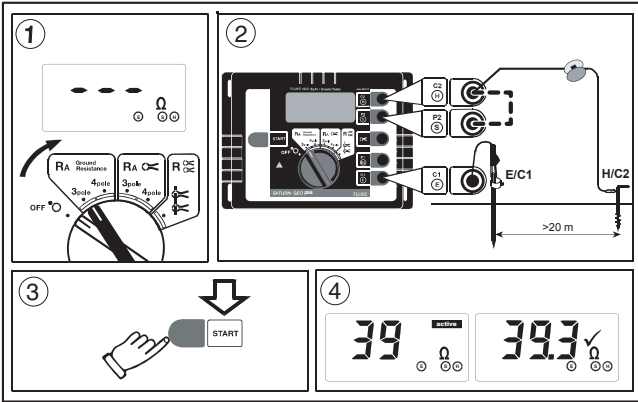

Figure 3. RA 2-pole Measurement

edv003.eps

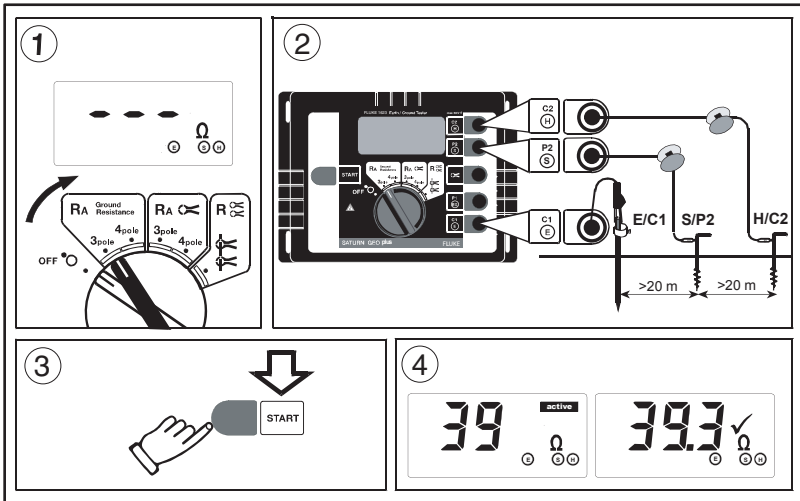

Figure 4. RA 3-pole Measurement

edv003b.eps

R_A 4-pole Measurements

Refer to Figure 5.

- ① Select function R_A 4-pole.
Display as shown below.

- ② Connect test leads.

Connect terminals E/C1 and ES/P1 to the earth system to be measured with the 2 supplied test leads (1.5 m). Place 2 ground stakes in earth/dirt. Minimum distance between earth electrode (E/C1), probe (S/P2), and auxiliary earth (H/C2) should be at least 20 m! The ES test lead eliminates the influence of the test leads.

Connect the stakes with the 25 m and 50 m cable reels to H/C2 and S/P2 as shown below.

- ③ Press START.

The “active” symbol indicates that a measurement is in progress. For a continuous measurement keep START pressed.

- ④ The symbol “✓” indicates a completed measurement. The result is kept on the display until a new measurement is started or the rotary switch is turned.

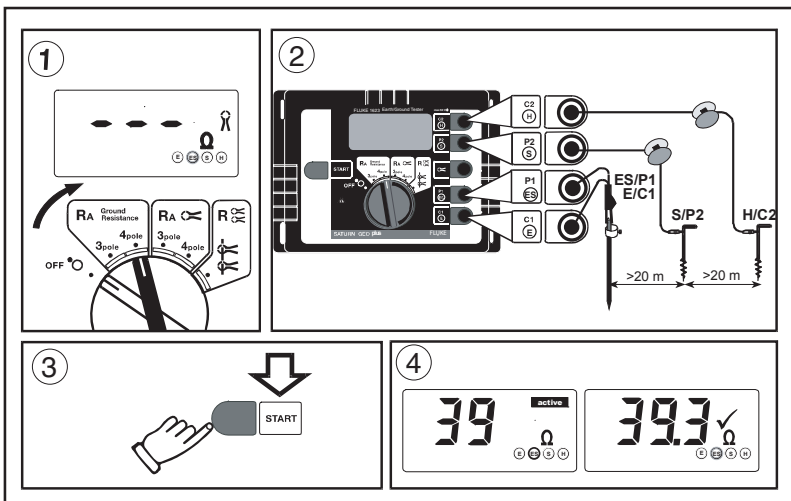



Figure 5. R_A 4-pole Measurements

edv004.eps

R_A 3-pole Selective Earth Resistance Measurement with Current Clamp

The R_A 3-pole Selective Earth Resistance Measurement with Current Clamp procedure is useful for measuring the resistance of different parallel sections of an earth/ground system. Refer to Figure 6.

- ① Select function R_A 3-pole .
Display as shown below.
- ② Connect test leads.
Connect the supplied test lead (1.5 m) to terminal E/C1 and its other end to the ground system to be measured. Place 2 ground stakes in earth/dirt. Minimum distance between earth electrode (E/C1), probe (S/P2) and auxiliary earth (H/C2) should be at least 20 m!
Connect stakes with 25 m and 50 m wires to H/C2 and S/P2 as shown. Connect current clamp with adapter cable as shown.
- ③ Press START.
The “active” symbol indicates that measurement is in progress. For continuous measurement keep START pressed.
- ④ Symbol “✓” indicates completed measurement. The result is kept on display until a new measurement is started or the rotary switch is turned.

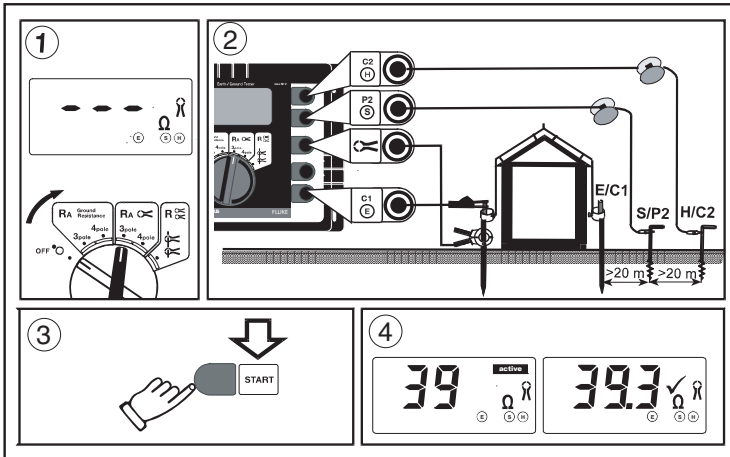

edu005.eps

Figure 6. R_A 3-pole Selective Earth Resistance Measurement with Current Clamp

R_A 4-pole Selective Earth Resistance Measurement with Current Clamp

The R_A 4-pole Selective Earth Resistance Measurement with Current Clamp procedure is useful for measuring the resistance of different parallel sections of an earth/ground system. Refer to Figure 7.

- ① Select function R_A 4-pole  .
Display as shown below.
- ② Connect test leads.
Connect terminals E/C1 and ES/P1 with the supplied safety test leads (1.5 m) to the earth electrode to be measured. Place 2 ground stakes in earth/dirt. Minimum distance between earth electrode (E/C1), probe (S/P2) and auxiliary earth (H/C2) should be at least 20 m! The ES test lead eliminates the influence of the test leads.
Connect stakes with 25 m and 50 m wires to H/C2 and S/P2 as shown.
Connect current clamp with adapter cable as shown.
- ③ Press START.
The “active” symbol indicates that measurement is in progress. For continuous measurement keep START pressed.
- ④ Symbol “✓” indicates completed measurement. The result is kept on display until a new measurement is started or the rotary switch is turned.

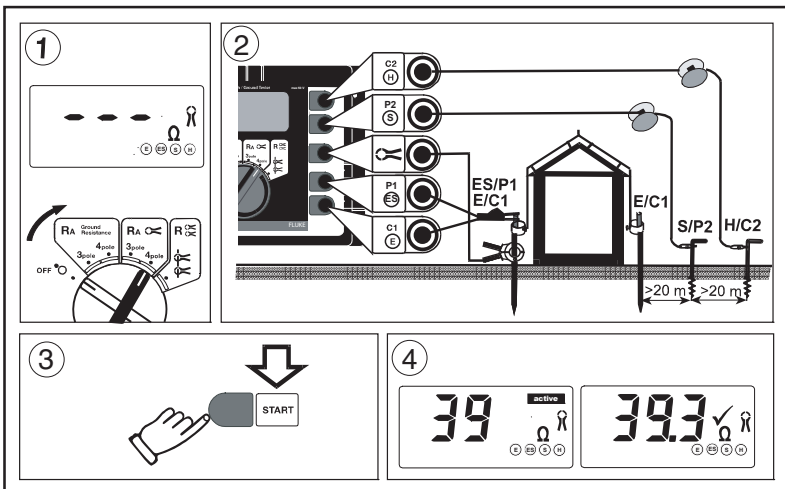

Figure 7. R_A 4-pole Selective Earth Resistance Measurement with Current Clamp

edv006.eps

Stakeless Ground Loop Measurement

Refer to Figure 8.

- ① Select function



Display as shown below.

- ② Connect current clamps.

Connect the inducing clamp (see Recommended Accessories) to terminals H/C2 and E/C1 using the supplied safety test leads (1.5 m) as shown.

Hint: Use the recommended current clamp for inducing only. Other current clamps are not suited.

Connect the second current clamp using the adapter cable (sensing current clamp).

Clamp both current clamps around the earth electrode, which will subsequently be measured.

Hint: Minimum distance between the two current clamps is 10 cm.

- ③ Press START.

The “active” symbol indicates that measurement is in progress. For continuous measurement keep START pressed.

- ④ Symbol “✓” indicates completed measurement. The result is kept on display until a new measurement is started or the rotary switch is turned.

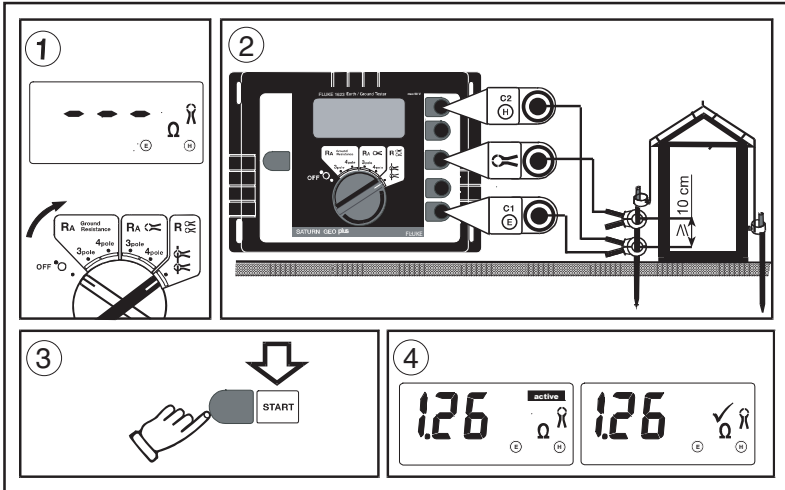

edv007.eps

Figure 8. Stakeless Ground Loop Measurement

Troubleshooting

Follow the steps in Table 3 and refer to Figure 9 for steps 1-5.

Table 3. Troubleshooting

Step	Description
①	<p>External voltage (Uext) too high</p> <p>If the external voltage applied to the instrument is too high, usually from leakage currents in the system under test, no measurement can be started (see “Technical data” for Uext limit).</p> <p><i>Hint: Reposition probe (S/P2) and restart measurement.</i></p>
②	<p>Auxiliary earth electrode resistance (RH) too high</p> <p>If the auxiliary earth electrode resistance is too high it is not possible to drive the current necessary for reliable measurements. The measurement is blocked (see “Technical data” for Rh limit).</p> <p><i>Hint: Check connection of test lead with terminal H/C2, check auxiliary earth stake.</i></p>
③	<p>Probe resistance (Rs) too high</p> <p>If the probe resistance is too high measurements are not reliable. The measurement is blocked (see “Technical data” for Rs limit).</p> <p><i>Hint: Check connection of test lead with terminal S/P2, check probe stake.</i></p>
④	<p>Weak batteries</p> <p>If the batteries are weak the supply voltage may break down during measurement. If there is enough energy to complete the measurement “” symbol is displayed - measuring results are valid. If not, a reset occurs.</p> <p><i>Hint: Replace batteries. Use 6 alkaline AA-type (LR6) batteries.</i></p>
⑤	<p>Is your R_A measurement result reliable?</p> <p>Probe S/P2 must be outside the potential gradient areas of E/C1 and H/C2 for accurate measurements. Normally a probe distance of more than 20m is sufficient. However in some environmental</p>

	<p>conditions (depending mainly on the soil resistivity) this may not suffice. To be sure reposition the probes and take several measurements. If the readings are approx. the same your measuring results are reliable, if not increase the probe distance.</p>
<p>⑥</p>	<p>Is the result of a “Stakeless ground loop measurement” reliable?</p> <p>Ensure that you are using the correct inducing clamp (see “Recommended Accessories”)! The clamp’s parameters are suited for this test method. Using an undefined clamp will render incorrect results.</p> <p>Ensure that the recommended minimum distance between the current clamp is kept. If the clamps are positioned too close together, the magnetic field of the inducing clamp will influence the sensing current clamp. To avoid mutual influencing, the distance between the clamps can be varied and a new test performed. If the measurement values vary only a little or not at all, the value can be regarded as reliable.</p>

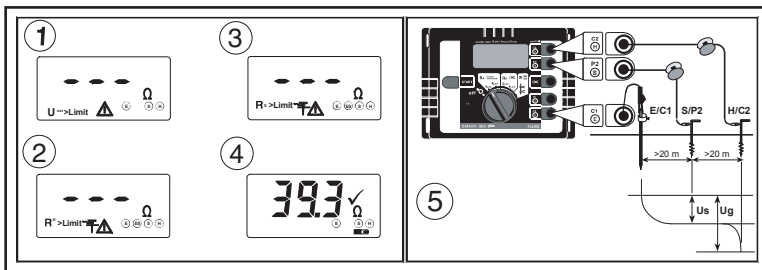

Figure 9. Troubleshooting

edv008.eps

Specifications

Note

Fluke reserves the right to modify specifications without notice for the purpose of product improvement.

Display: 1999 digit LCD	Display with special symbols, digit height 25 mm, fluorescent backlight
User interface:	Instant measurement through TURN and START one button concept. The only operating elements are rotary switch and START button.
Robust and Waterproof	Instrument is designed for tough environmental conditions (rubber protective cover, IP56).
Temperature ranges:	
Working temp.:	-10 °C ... +50 °C (+14 °F ... +122 °F)
Operating temp.:	0 °C ... +35 °C (+32 °F ... +95 °F)
Storage temp.:	-20 °C ... +60 °C (-4 °F ... +140 °F)
Reference temp.:	+23 °C ± 2 °C (+73 °F ± 4 °F)
The chart of four temperature ranges for the instrument exist to satisfy European Standards requirements; the instrument can be used over the full Working temperature range by using the temperature coefficient to calculate accuracy at the ambient temperature of use.	
Temp. coefficient:	± 0.1 % of reading / K
Intrinsic error:	Refers to the reference temperature range and is guaranteed for 1 year.
Operating error:	Refers to the operating temperature range and is guaranteed for 1 year.
Climatic class:	C1 (IEC 654-1), -5 °C...+45 °C, 5 %...95 % RH
Protective type:	IP56 for case, IP40 for battery door according to EN 60529
Safety	Protection by double and/or reinforced insulation. max 50 V to earth
EMC (Emission Immunity):	IEC 61326-1:1997 Class A

Quality system:	developed, designed and manufactured according to DIN ISO 9001
External voltage:	$U_{ext,max} = 24 \text{ V}$ (DC, AC < 400 Hz), measurement inhibited for higher values
Uext rejection:	>120 dB (162/3, 50, 60, 400 Hz)
Measuring time:	typical 6 sec
Max. overload:	250 Vrms (pertains to misuse)
Auxiliary power:	6 x 1.5 V mignon cells alkali-manganese (type AA LR6)
Battery life span:	typical > 3000 measurements
Dimensions:	240 x 180 x 110 mm
Weight:	1.1 kg (including batteries)

R_A 3-pole ground resistance measurement

(IEC 1557-5)

Switch position	Resolution	Measuring range	Intrinsic error	Operating error
R _A 3-pole	0,001 ... 10 Ω	0,001 Ω ... 19,99 kΩ	±(2 % rdg + 3 d)	±(5 % rdg + 3 d)

For 2-pole measurements connect terminals H and S with the supplied connector cable!

Measuring principle: Current and voltage measurement

Measuring voltage:	$U_m = 48 \text{ Vac}$.
Short-circuit current:	> 50 mA
Meas. frequency:	128 Hz (125 Hz on request)
Probe resistance (R _s):	max 100 kΩ
Auxiliary earth electrode resistance (R _h):	max. 100 kΩ
Additional error from R _h and R _s :	$R_h[k\Omega] \cdot R_s[k\Omega]/R_a[\Omega] \cdot 0,2 \%$
Monitoring of R _s and R _h with error indicator.	

Automatic range selection.

Measurement is not performed if the current through the current clamp is too low.

R_A 4-pole ground resistance measurement (IEC 1557-5)

Switch position	Resolution	measuring range	Intrinsic error	Operating error
Ra 4-pole	0,001 ... 10 Ω	0,001 Ω ... 19,99 kΩ	±(2% rdg + 3 d)	±(5% rdg + 3 d)

Measuring principle: Current/voltage measurement

- Measuring voltage: $U_m = 48 \text{ Vac}$.
- Short-circuit current: $> 50 \text{ mA}$
- Measuring frequency: 128 Hz (125 Hz on request)
- Probe resistance (R_s+ Res): $\text{max. } 100 \text{ k}\Omega$
- Auxiliary earth electrode resistance (R_h): $\text{max. } 100 \text{ k}\Omega$
- Additional error from R_h and R_s: $R_h[\text{k}\Omega] \cdot R_s[\text{k}\Omega/\text{Ra}[\Omega]] \cdot 0,2 \%$

Monitoring of R_s, and R_h with error indicator.

Automatic range selection.

R_A 3-pole selective ground resistance measurement with current clamp (R_A )

Switch position	Resolution	Measuring range	Intrinsic error	Operating error
Ra 3-pole 	0.001 ... 10 Ω	0.001 Ω .. 19.99 kΩ	±(7% rdg + 3 d)	± (10% rdg + 5 d)

Measuring principle: Current/voltage measurement (with external current clamp)

- Measuring voltage: $U_m = 48 \text{ VAC}$.
- Short-circuit current: $> 50 \text{ mA}$
- Measuring frequency: 128 Hz (125 Hz on request)

Probe resistance (Rs): max. 100 kΩ

Auxiliary earth electrode resistance (Rh): max. 100 kΩ

Monitoring of Rs, and Rh with error indicator.

Measurement is not performed if the current through the current clamp is too low.

Automatic range selection.

R_A 4- pole selective ground resistance measurement with current clamp (R_A )

Switch position	Resolution	Measuring range	Intrinsic error	Operating error
Ra 4-pole 	0.001 ... 10 Ω	0.001 Ω .. 19.99 kΩ	±(7% rdg + 3 d)	± (10% rdg + 5 d)

Measuring principle: Current/voltage measurement (with external current clamp)

Measuring voltage: Um = 48 VAC.

Short-circuit current: > 50 mA

Measuring frequency: 128 Hz (125 Hz on request)

Probe resistance (Rs): max. 100 kΩ

Auxiliary earth electrode resistance (Rh): max. 100 kΩ

Monitoring of Rs, and Rh with error indicator.

Measurement is not performed if the current through the current clamp is too low.

Automatic range selection.

Stakeless ground loop measurement ()

Switch position	Resolution	Measuring range	Intrinsic error	Operating error
Ra 4-pole 	0.001 ... 0.1 Ω	0.001 Ω .. 199.9 Ω	±(7% rdg + 3 d)	± (10% rdg + 5 d)

Measuring principle: Stakeless measurement of resistance in closed loops using two current transformers

Measuring voltage: $U_m = 48 \text{ VAC (primary)}$

Measuring frequency: 128 Hz (125 Hz on request)

Noise current (I_{ext}): max. I_{ext} = 10 A (AC) (R_a < 20 Ω)

max. I_{ext} = 2 A (AC) (R_a > 20 Ω)

Automatic range selection

The information regarding stakeless ground loop measurements is only valid when used in conjunction with the recommended current clamps at the minimum distance specified.

Service

If you suspect that the tester has failed, review this manual to make sure you are operating it correctly. If the meter still fails to operate properly, pack it securely (in its original container if available) and forward it, postage paid, to the nearest Fluke Service Center. Include a brief description of the problem. Fluke assumes NO responsibility for damage in transit.

To locate an authorized service center, call Fluke using any of the phone numbers listed below:

USA: 1-888-99-FLUKE (1-888-993-5853)

Canada: 1-800-36-FLUKE (1-800-363-5853)

Europe: +31 402-678-200

Japan: +81-3-3434-0181

Singapore: +65-738-5655

Anywhere in the world: +1-425-446-5500

Or, visit us on the World Wide Web: www.fluke.com. To register your product, visit register.fluke.com

Storage

In case the instrument is either not used or stored for a longer period, remove batteries and keep them stored separately to avoid possible damage by leaking battery electrolyte.

