

SIRCO M and MV

Universal load break switches
from 16 to 160 A



4 pole **SIRCO M**
direct operation



4 pole **SIRCO MV**
direct operation

The solution for

- > Main incoming load break
- > Distribution load break
- > Machine control
- > Local safety load break



Strong points

- > Total integration
- > A wide range of accessories
- > Upgradeability
- > Compliance with major certifications and approvals
- > Specific characteristics

Conformity to standards

- > IEC 60947-3



- > Other standards available



*See pages SIRCO UL and CSA range

Approvals and certifications⁽¹⁾



(1) Product reference on request.

Function

SIRCO M and **MV** are manually operated modifiable and modular multipolar load break switches.

They make and break under load conditions and provide safety isolation for any low voltage circuit, particularly for machine control circuits.

Through the use of accessories, **SIRCO M** can be transformed into multipolar load break or 3/4 pole changeover switches. **SIRCO M** changeover switches provide on load changeover switching between two sources or two low voltage power circuits, as well as their safety isolation.

Advantages

Total integration

The **SIRCO M** and **MV** fully integrate isolation, breaking and switching functions.

Within a single product, **SIRCO M** offers front, right side or left side operation. Their highly functional design enables the product to be easily transformed from a load break switch to a changeover switch, offering a highly innovative modular solution for numerous applications.

A wide range of accessories

A single standard module, which can be complemented with a choice of accessories, offers a range of advantages:

- Simplicity when choosing the device.
- Flexibility to adapt to the most varied applications.
- Reduction in the cost of management and storage.

Upgradeability

Its wide range of accessories means that the **SIRCO M** can be upgraded even after it has been commissioned, enabling future requirements to be met.

Compliance with major certifications and approvals

The **SIRCO M** and **MV** range of load break switches have been designed, qualified and tested according to the criteria defined by standards IEC 60947-3, UL508 and UL98.

This process guarantees a high quality level for the product which is fully adapted to arduous operating environments.

General characteristics

- Double break per pole.
- Mounting options: DIN rail, panel or modular panel with 45 mm front cut out.
- IP20 accessories and device.
- Severe utilisation categories (AC-22 and AC-23).

Specific characteristics

SIRCO M:

- Positive break indication.
- Contact point technology.
- Product can be mounted directly on the door or panel side; see "Door mounting kit" in the accessory section.

SIRCO MV:

- Visible double breaking based on a sliding contact system (**SIRCO** type, see page
- Positive break indication.

What you need to know

SIRCO M

- SIRCO M can be operated in 3 different ways:



Complete switch body for toggle operation



Direct front operation with handle



External operation
 front, left side or right side

- The SIRCO M is a **3 pole** load break switch which is available from **16 to 125 A**. It can be combined with a switched 4th pole, an unswitched neutral or PE pole and pre-break and signalling auxiliary contacts.

page 726).

- From **16 to 125 A**, through the wide range of available accessories, it is possible to convert a 3 pole load break switch into a **4, 6 or 8 pole load break switch** or a **3/4 pole changeover switch**. Through use of its door mounting kit, SIRCO M load break switches can be mounted on the panel door.



Changeover switches I - 0 - II

SIRCO MV

- 3 operations are available:



Direct front operation



External **right side** operation

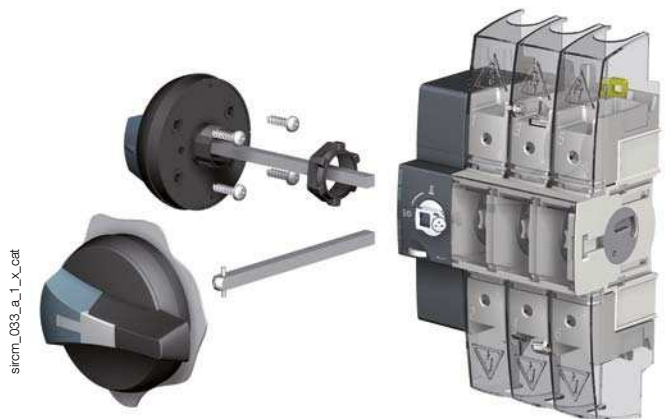

External **front and left side** operation

- SIRCO MV can be ordered in **3 or 4 pole** from **100 to 160 A**.
- Two types of auxiliary contacts are available:
 - U-type pre-break,
 - M-type for signalisation.

SIRCO M and MV

Universal load break switches

from 16 to 160 A

References

SIRCO M

SIRCO M - from 16 to 125 A									
Rating (A) / Frame size	No. of poles	Complete switch body toggle operation	Switch body	Direct handle	Door interlocked external front and right side handle ⁽⁸⁾	External left side handle ⁽⁶⁾	Front external handle for changeover switches ⁽⁶⁾	Shaft for external front and side handle ⁽⁶⁾	4 th pole
16 A / M1	3 P	2205 3000	2200 3000 ⁽¹⁾⁽²⁾⁽³⁾						2200 1000
20 A / M1	3 P	2205 3001	2200 3001 ⁽¹⁾⁽²⁾⁽³⁾						2200 1001
25 A / M1	3 P	2205 3002	2200 3002 ⁽¹⁾⁽²⁾⁽³⁾						2200 1002
32 A / M1	3 P	2205 3003	2200 3003 ⁽¹⁾⁽²⁾⁽³⁾	M00 type Blue 2299 5012 Red 2299 5013	S00 type I-0 Black IP55 1471 1111 ⁽⁴⁾ Black IP65 1473 1111 ⁽⁴⁾ Red/Yellow IP65 1474 1111 ⁽⁴⁾	S00 type I-0 Black IP65 147A 5111 Red/Yellow IP65 147B 5111	S00 type I-0-II Black IP65 1473 1113 ⁽⁴⁾ I-I+II-II Black IP65 1473 1114 ⁽⁴⁾	SO, S00 type 150 mm 1407 0515 200 mm 1407 0520 320 mm 1407 0532	2200 1003 2200 1004 2200 1004 2200 1006
40 A / M1	3 P	2205 3004	2200 3004 ⁽¹⁾⁽²⁾⁽³⁾						2200 1004
63 A / M2	3 P	2205 3006	2200 3006 ⁽¹⁾⁽²⁾⁽³⁾						2200 1006
80 A / M2	3 P	2205 3008	2200 3008 ⁽¹⁾⁽²⁾⁽³⁾						2200 1008
100 A / M3	3 P		2200 3010 ⁽¹⁾⁽²⁾⁽³⁾	M01 type Blue 2299 5032	S0 type I-0 Black IP55 1481 1111 ⁽⁴⁾ Black IP65 1483 1111 ⁽⁴⁾ Red/Yellow IP65 1484 1111 ⁽⁴⁾	S0 type I-0 Black IP65 148A 5111 Red/Yellow IP65 148B 5111	S00 type I-0-II Black IP65 1473 0113 I-I+II-II Black IP65 1473 0114		2200 1010 2200 1011
125 A / M3	3 P		2200 3011 ⁽¹⁾⁽²⁾⁽³⁾						2200 1011

(1) Front and side operation.

(2) For a 6-pole device in direct operation, order 2 x 3 pole device + conversion kit (for external operation, add the shaft + the handle).

(3) For an 8-pole device in direct operation, order 2 x 3 pole device + 2 x 4th poles + conversion kit (for external operation, add the shaft + the handle).

(4) Defeatable handle.

(5) Top and bottom.

(6) Delivered with a direct handle.

(7) Delivered with a shaft.

(8) Other handles are available. Please see accessory pages.

SIRCO M

SIRCO M - from 16 to 125 A

Rating (A) / Frame size	No. of poles	Complete switch body toggle operation	Switch body	Unswitched neutral pole	Unswitched protective earth module	Auxiliary contact	Terminal shrouds	Door mounting kit
16 A / M1	3 P	2205 3000	2200 3000 ⁽¹⁾⁽²⁾⁽³⁾					
20 A / M1	3 P	2205 3001	2200 3001 ⁽¹⁾⁽²⁾⁽³⁾					3/4 P Complete protection
25 A / M1	3 P	2205 3002	2200 3002 ⁽¹⁾⁽²⁾⁽³⁾	1 P 2200 5005	1 P 2200 9005	M type	1 P 2294 1005 ⁽⁵⁾ 3 P 2294 3005 ⁽⁵⁾	IP2X 2299 3309 ⁽⁷⁾
32 A / M1	3 P	2205 3003	2200 3003 ⁽¹⁾⁽²⁾⁽³⁾			1 contact NO + NC 2299 0001		Compact design
40 A / M1	3 P	2205 3004	2200 3004 ⁽¹⁾⁽²⁾⁽³⁾					2299 3409 ⁽⁷⁾
63 A / M2	3 P	2205 3006	2200 3006 ⁽¹⁾⁽²⁾⁽³⁾	1 P 2200 5009	1 P 2200 9009	1 contact 2 NC 2299 0011	1 P 2294 1009 ⁽⁵⁾ 3 P 2294 3009 ⁽⁵⁾	6/8 P Steel support 2299 3609 ⁽⁷⁾
80 A / M2	3 P	2205 3008	2200 3008 ⁽¹⁾⁽²⁾⁽³⁾					
100 A / M3	3 P		2200 3010 ⁽¹⁾⁽²⁾⁽³⁾	1 P 2200 5011	1 P 2200 9011		1 P 2294 1011 ⁽⁵⁾ 3 P 2294 3016 ⁽⁵⁾	3/4 P Steel support
125 A / M3	3 P		2200 3011 ⁽¹⁾⁽²⁾⁽³⁾					2299 3609 ⁽⁷⁾

(1) Front and side operation.

(2) For a 6-pole device in direct operation, order 2 x 3 pole device + conversion kit (for external operation, add the shaft + the handle).

(3) For an 8-pole device in direct operation, order 2 x 3 pole device + 2 x 4th poles + conversion kit (for external operation, add the shaft + the handle).

(4) Defeatable handle.

(5) Top and bottom.

(6) Delivered with a direct handle.

(7) Delivered with a shaft.

(8) Other handles are available. Please see accessory pages.

SIRCO MV

SIRCO M - from 100 to 160 A

Rating (A)	No. of poles	Switch body	Direct handle	Door interlocked external front and right side handle ⁽⁴⁾	External left side handle ⁽⁴⁾	Shaft for external front and side handle ⁽⁴⁾	Auxiliary signal contact	Pre-break auxiliary contact	Terminal shrouds
100 A	3 P	2200 3110							
	4 P	2200 4110							
125 A	3 P	2200 3012	M0b type Blue 2299 5042 ⁽¹⁾	S0 type I-0 Black IP65 1491 0111 ⁽²⁾	S0 type I-0 Black IP65 149A 9111	S0 type 150 mm 1409 0615 200 mm 1409 0620	M type 1 contact NO + NC 2299 0001	U type 1 contact NC 3999 0701	3 P 2294 3016 ⁽³⁾
	4 P	2200 4012	M0 type Blue 2299 5022	Black IP65 1493 0111 ⁽²⁾ Red/Yellow IP65 1494 0111 ⁽²⁾	Red/Yellow IP65 149B 9111	320 mm 1409 0632	1 contact 2 NC 2299 0011	1 contact NO 3999 0702	4 P 2294 4016 ⁽³⁾
160 A	3 P	2200 3016							
	4 P	2200 4016							

(1) Standard.

(2) Defeatable handle.

(3) Top and bottom.

(4) Other handles are available. Please see accessory pages.

SIRCO M and MV

Universal load break switches

from 16 to 160 A

Accessories

Direct operation handle

For SIRCO M

Rating (A) / Frame size	Handle colour	Handle	Reference
16 ... 80 / M1 ... M2	Blue	M00 type	2299 5012 ⁽¹⁾
16 ... 80 / M1 ... M2	Red	M00 type	2299 5013
100 ... 125 / M3	Blue	M01 type	2299 5032 ⁽¹⁾

(1) Standard.

For SIRCO MV

Rating (A)	Handle colour	Handle	Reference
100 ... 160	Blue	M0b type	2299 5042 ⁽¹⁾
100 ... 160	Blue	M0 type	2299 5022

(1) Standard.

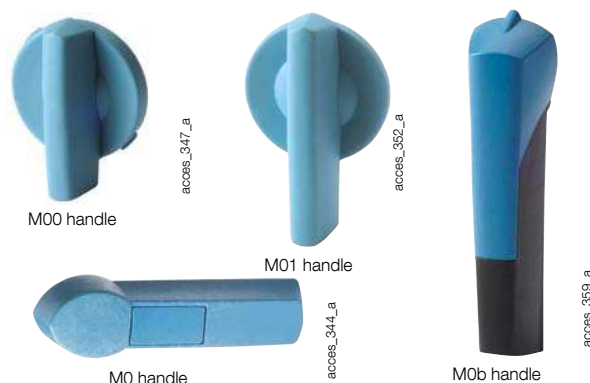

External handle operation - SIRCO M

S000 type handle

Rating (A) / Frame size	Type	No. of poles	Operation	Handle colour	External IP	Defeatable handle	Reference
16 ... 80 / M1... M2	Switch	3/4 P	Front and side operation	Black	IP65	no	1463 5111
	Switch	3/4 P	Front and side operation	Red/Yellow	IP65	no	1464 5111
16 ... 80 / M1... M2	Changeover switches I - 0 - II	3/4 P	Front	Black	IP65	no	1463 5113
	Changeover switches I - I+II - II	3/4 P	Front	Black	IP65	no	1463 5114



S000 handle

access_307_a_1_cat

S00 type handle

Rating (A) / Frame size	Type	No. of poles	Operation	Handle colour	External IP	Defeatable handle	Reference
16 ... 80 / M1... M2	Switch	3/4 P ⁽¹⁾	Front and side operation	Black	IP55	yes	1471 1111
	Switch	3/4 P ⁽¹⁾	Front and side operation	Black	IP65	yes	1473 1111
	Switch	3/4 P ⁽¹⁾	Front and side operation	Red/Yellow	IP65	yes	1474 1111
	Switch	3/4 P	Left side	Black	IP65	no	147A 5111
	Switch	3/4 P	Left side	Red/Yellow	IP65	no	147B 5111
100 ... 125 / M3	Switch	6/8 P	Front	Black	IP55	yes	1471 0111
	Switch	6/8 P	Front	Black	IP65	yes	1473 0111
	Switch	6/8 P	Front	Red/Yellow	IP65	yes	1474 0111
16 ... 80 / M1... M2	Changeover switches I - 0 - II	3/4 P	Front	Black	IP65	yes	1473 1113
	Changeover switches I - I+II - II	3/4 P	Front	Black	IP65	yes	1473 1114
100 ... 125 / M3	Changeover switches I - 0 - II	3/4 P	Front	Black	IP65	yes	1473 0113
	Changeover switches I - I+II - II	3/4 P	Front	Black	IP65	yes	1473 0114



S00 handle

access_341_a_1_cat

(1) Can also be used with 6 and 8 poles with front operation.

External operation handle - SIRCO M (continued)

S0 type handle

Rating (A) / Frame size	Type	No. of poles	Operation	Handle colour	External IP	Defeatable handle	Reference
100 ... 125 / M3	Switch	3/4 P	Front and side operation	Black	IP55	yes	1481 1111
	Switch	3/4 P	Front and side operation	Black	IP65	yes	1483 1111
	Switch	3/4 P	Front and side operation	Red/Yellow	IP65	yes	1484 1111
	Switch	3/4 P	Left side	Black	IP65	no	148A 5111
	Switch	3/4 P	Left side	Red/Yellow	IP65	no	148B 5111



access_343_a

S01 type handle

Rating (A) / Frame size	Type	No. of poles	Operation	Handle colour	External IP	Defeatable handle	Reference
16 ... 125 / M1 ... M3	Switch	3/4 P ⁽²⁾	Front and side operation	Black	IP65	yes	1403 2111
	Switch	3/4 P ⁽²⁾	Front and side operation	Red/Yellow	IP65	yes	1404 2111
16 ... 125 / M1 ... M3	Changeover switches I - 0 - II	3/4 P	Front	Black	IP65	yes	1403 2113
	Changeover switches I - 0 - II	3/4 P	Front	Black	IP65	yes	1403 2813 ⁽¹⁾
	Changeover switches I - I+II - II	3/4 P	Front	Black	IP65	yes	1403 2114
	Changeover switches I - I+II - II	3/4 P	Front	Black	IP65	yes	1403 2814 ⁽¹⁾



S0 handle

S01 handle

access_304_a_1_cat

(1) Padlockable in 3 positions.

(2) Can also be used with 6 and 8 pole devices from 16 to 40 A.

External operation handle - SIRCO MV

S0 type handle

Rating (A)	Type	No. of poles	Operation	Handle colour	External IP	Defeatable handle	Reference
100 ... 160	Switch	3/4 P	Front and side operation	Black	IP55	yes	1491 0111
100 ... 160	Switch	3/4 P	Front and side operation	Black	IP65	yes	1493 0111
100 ... 160	Switch	3/4 P	Front and side operation	Red/Yellow	IP65	yes	1494 0111
100 ... 160	Switch	3/4 P	Left side	Black	IP65	no	149A 9111
100 ... 160	Switch	3/4 P	Left side	Red/Yellow	IP65	no	149B 9111



S0 handle

access_343_a

S1 type handle

Rating (A)	Type	No. of poles	Operation	Handle colour	External IP	Defeatable handle	Reference
100 ... 160	Switch	3/4 P	Front	Black	IP55	yes	1411 2111
100 ... 160	Switch	3/4 P	Front	Black	IP65	yes	1413 2111
100 ... 160	Switch	3/4 P	Front	Red/Yellow	IP65	yes	1414 2111
100 ... 160	Switch	3/4 P	Right side	Black	IP55	no	1415 2111
100 ... 160	Switch	3/4 P	Right side	Black	IP65	no	1417 2111
100 ... 160	Switch	3/4 P	Right side	Red/Yellow	IP65	no	1418 2111
100 ... 160	Switch	3/4 P	Left side	Black	IP65	no	141A 2111
100 ... 160	Switch	3/4 P	Left side	Red/Yellow	IP65	no	141B 2111



S1 Handle

access_284_a_2_cat

SIRCO M and MV

Universal load break switches

from 16 to 160 A

Accessories (continued)

Shaft for external handle

SIRCO M 3/4 P

Rating (A) / Frame size	Handle type	Type	Length (mm)	Reference
16 ... 125 / M1... M3	S000 / S00 / S0	Switch	150 mm	1407 0515
	S000 / S00 / S0	Switch	200 mm	1407 0520
	S000 / S00 / S0	Switch	320 mm	1407 0532
	S01	Switch	200 mm	1404 0520
	S01	Switch	320 mm	1404 0532
	S01	Switch	400 mm	1404 0540



acces_346_a_1_cat

SIRCO M 6/8 pole load break switch and 3/4 pole changeover switch

Rating (A)	Handle type	Type	Length (mm)	Reference
16 ... 80 / M1...M2	S000, S00	6/8 P and changeover switch	150 mm	1407 0515
	S000, S00	6/8 P and changeover switch	200 mm	1407 0520
	S000, S00	6/8 P and changeover switch	320 mm	1407 0532
100 ... 125 / M3	S00	6/8 P and changeover switch	150 mm	1409 0615
	S00	6/8 P and changeover switch	200 mm	1409 0620
	S00	6/8 P and changeover switch	320 mm	1409 0632
16 ... 40 / M1 ... M2	S01	6/8 P	200 mm	1404 0520
	S01	6/8 P	320 mm	1404 0532
	S01	6/8 P	400 mm	1404 0540
	S01	Changeover switch	200 mm	1404 0520
	S01	Changeover switch	320 mm	1404 0532
	S01	Changeover switch	400 mm	1404 0540
100 ... 125 / M3	S01	Changeover switch	200 mm	1404 0520
	S01	Changeover switch	320 mm	1404 0532

Use

Standard lengths:

- 150 mm,
- 200 mm,
- 320 mm,
- 400 mm.

Other lengths: Please consult us.

For 3/4 pole switches, shaft extensions are for external front and side operation.

For 6/8 pole switches and changeover switches, shaft extensions for front operation only.

For SIRCO MV

Rating (A)	Handle type	Type	Length (mm)	Reference
100 ... 160	S0	Switch	150 mm	1409 0615
100 ... 160	S0	Switch	200 mm	1409 0620
100 ... 160	S0	Switch	320 mm	1409 0632
100 ... 160	S1	Switch	200 mm	1401 0620
100 ... 160	S1	Switch	320 mm	1401 0632
100 ... 160	S1	Switch	400 mm	1401 0640

Shaft guide for external operation

Use

To guide the shaft extension into the external handle.

This accessory enables the handle to engage the extension shaft with a misalignment of up to 15 mm.

Required for a shaft length over 320 mm.

Description	Handle type	To be ordered in multiples of	Reference
Shaft guide	S00 and S0 / S000	10 pieces	1419 0000
Shaft guide	S01 and S1	1 piece	1429 0000



acces_280_a_2_cat

Additional pole for SIRCO M

Switched fourth pole module

Rating (A) / Frame size	No. of poles	Type	Reference
16 / M1	1 P	switched	2200 1000
20 / M1	1 P	switched	2200 1001
25 / M1	1 P	switched	2200 1002
32 / M1	1 P	switched	2200 1003
40 / M1	1 P	switched	2200 1004
63 / M2	1 P	switched	2200 1006
80 / M2	1 P	switched	2200 1008
100 / M3	1 P	switched	2200 1010
125 / M3	1 P	switched	2200 1011

Use

Adds one or two poles and transforms:

- a 3 pole SIRCO M into a 4 pole load break switch,
- a 6 pole SIRCO M into a 8 pole load break switch,
- a 3 pole SIRCO M into a 4 pole changeover switch.



4th pole

Protective earth module

Neutral pole

Neutral pole

Rating (A) / Frame size	No. of poles	Type	Reference
16 ... 40 / M1	1 P	unswitched	2200 5005
63 ... 80 / M2	1 P	unswitched	2200 5009
100 ... 125 / M3	1 P	unswitched	2200 5011

Use

Transforms the 3-pole switch into a 3-pole + solid neutral.

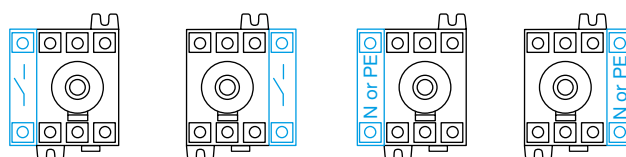

Protective earth module

Rating (A) / Frame size	No. of poles	Type	Reference
16 ... 40 / M1	1 P	unswitched	2200 9005
63 ... 80 / M2	1 P	unswitched	2200 9009
100 ... 125 / M3	1 P	unswitched	2200 9011

Use

Adds 1 protective earth module pole to the switch-disconnector.

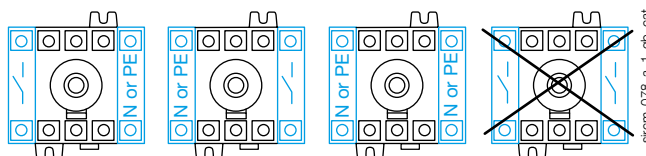

Additional pole configuration

Terminal shrouds

Use

Top and bottom protection against direct contact with the terminals or connection parts.

Available in 1 or 3 pole versions for SIRCO M and in 3 or 4 pole versions for SIRCO MV.

An opening on each terminal cover makes it possible to insert a temperature measurement probe.

For SIRCO M

Rating (A) / Frame size	No. of poles	Position	Reference
16 ... 40 / M1	1 P	top and bottom	2294 1005
16 ... 40 / M1	3 P	top and bottom	2294 3005
63 ... 80 / M2	1 P	top and bottom	2294 1009
63 ... 80 / M1	3 P	top and bottom	2294 3009
100 ... 125 / M3	1 P	top and bottom	2294 1011
100 ... 125 / M3	3 P	top and bottom	2294 3016

For SIRCO MV

Rating (A)	No. of poles	Position	Reference
100 ... 160	3 P	top and bottom	2294 3016
100 ... 160	4 P	top and bottom	2294 4016

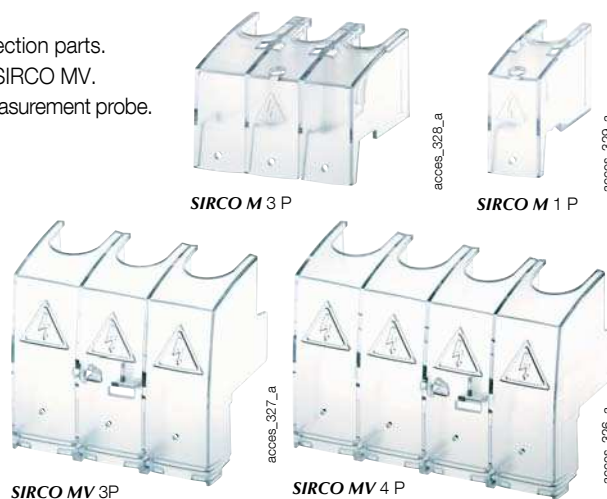

SIRCO M 3 P

SIRCO M 1 P

SIRCO MV 3 P

SIRCO MV 4 P

SIRCO M and MV

Universal load break switches

from 16 to 160 A

Accessories (continued)

M type auxiliary contacts

Use

Pre-break and signalisation of positions 0 and I by NO+NC or 2 NO auxiliary contacts.

They allow to anticipate the switching of the main poles. They can be mounted on the left or on the right side of the device.

Max 4 auxiliary contacts (2 modules).

Pre-break is not guaranteed on the SIRCO MV.

Characteristics

NO+NC auxiliary contacts: IP2 with front operation.

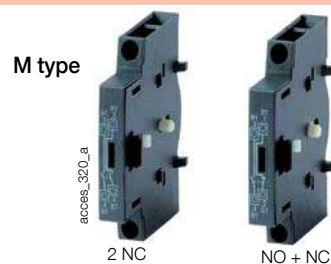

For SIRCO M

Rating (A) / Frame size	Number of AC	Type of AC	Reference
16 ... 125 / M1...M3	1 AC	NO + NC	2299 0001
	1 AC	2 NO	2299 0011

For SIRCO MV

Rating (A)	Number of AC	Type of AC	Reference
100 ... 160	1 AC	NO + NC	2299 0001
100 ... 160	1 AC	2 NO	2299 0011

Characteristics

Contact type	Nominal current (A)	Operating current I _e (A)	
		AC-13	AC-15
NO + NC	10	10	6

Auxiliary contact configurations for SIRCO MV

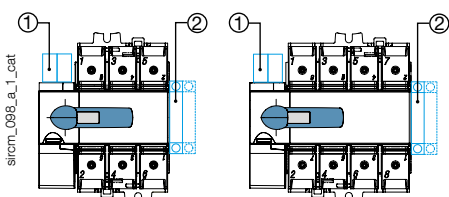

- Maximum 2 "U" type auxiliary contacts.
- Maximum 2 "M" type auxiliary contact modules.

For SIRCO MV

Rating (A)	Number of AC	Type of AC	Reference
100 ... 160	1 AC	NC	3999 0701
100 ... 160	1 AC	NO	3999 0702

Characteristics

Contact type	Nominal current (A)	Operating current I _e (A)			
		250 VAC AC-15	400 VAC AC-15	24 VDC DC-13	48 VDC DC-13
NC	10	3	1.8	2.8	1.4
NO	10	3	1.8	2.8	1.4

Auxiliary contacts configurations for SIRCO M

Max: 2 blocks / Max: 2 AC

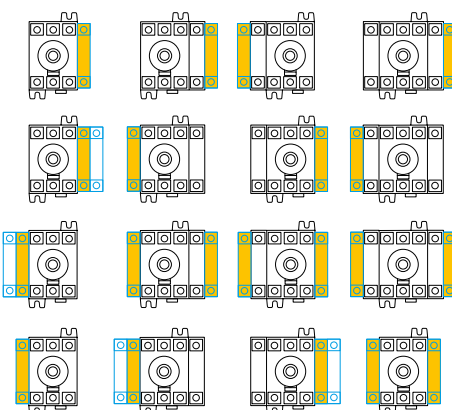
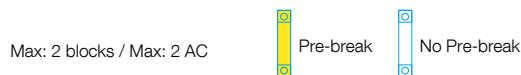

U type



Use

Pre-break and signalisation by NO or NC auxiliary contact can be mounted on the device. Maximum 2 auxiliary contacts. Only available for SIRCO MV switches.

Conversion kit

Use

It must be ordered together with the handle for external control.

This accessory enables the assembly of two 3 pole switches (+ additional pole) in order to create :

- a 6 or 8 pole SIRCO M load break switch,
- a 3 or 4 pole SIRCO M changeover switch.

SIRCO M changeover switches provide on load changeover switching between two sources or two low voltage power circuits, as well as their safety isolation (I - 0 - II); transfer without interruption of the supply is also possible (I - I+II - II).

Load break switches 6/8 P

Rating (A) / Frame size	Type	Reference
16 ... 80 / M1 ... M2	6/8 P switch	2269 6009
100 ... 125 / M3	6/8 P switch	2269 6011

Changeover switches I - 0 - II

Rating (A) / Frame size	Type	Reference
16 ... 80 / M1 ... M2	Changeover switches I - 0 - II	2209 6009
100 ... 125 / M3	Changeover switches I - 0 - II	2209 6011

Changeover switches I - I+II - II

Rating (A) / Frame size	Type	Reference
16 ... 80 / M1 ... M2	Changeover switches I - I+II - II	2299 6009
100 ... 125 / M3	Changeover switches I - I+II - II	2299 6011



Conversion kit for 6 or 8 pole load break switches



Conversion kit for changeover switches I - 0 - II



Conversion kit for changeover switches I - I+II - II

Door mounting kit⁽¹⁾

Use

This kit enables a direct mounting of the switch on the door panel, on the right or left side of the panel.

The connection clamps of the switch are always accessible.

The external handle is quick and easy to install with the supplied internal locking nut mounted on the inside of the enclosure.

3 kits are available:

- one for complete protection IP2X
- one with compact design
- one in steel for 6/8 P and 100/125 A.

For SIRCO M

(1) Kit compatible with S00 type handle only.

Rating (A) / Frame size	No. of poles	Description	Reference
16 ... 80 / M1 ... M2	3/4 P	Complete protection IP2X	2299 3309
	3/4 P	Compact version	2299 3409
	6/8 P	Metallic support	2299 3609
100 ... 125	3/4 P	Metallic support	2299 3609

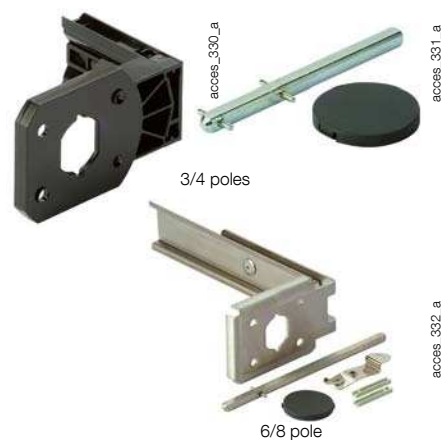

Cap for side operation mounting

Use

This accessory enables the front face of the SIRCO M to be capped when the switch is side operated. 20 pieces supplied per pack.

This piece snaps into place directly on the front face of the switch.

For SIRCO M

Rating (A) / Frame size	Pack	Reference
16 ... 125 / M1 ... M3	20 pieces	2299 9409



6/8 pole joining accessory

Use

This accessory enables two 3/4 pole switches to be coupled in order to provide a 6 or 8 pole switch for external side operation. 40 pieces supplied per pack.

For multi-pole switches, please consult us.

For SIRCO M

Rating (A) / Frame size	Pack	Reference
16 ... 80 / M1 ... M2	40 pieces	2299 9909

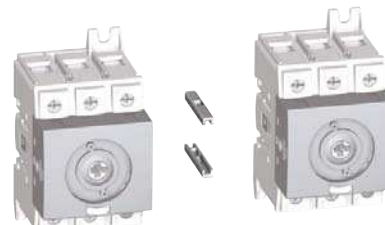

DIN rail locking clip

Use

This locking clip prevents the SIRCO MV from sliding when DIN rail mounted.

For SIRCO MV

Rating (A)	Type	Reference
100 ... 160	Locking clip M4	5000 0041
100 ... 160	Locking clip M5	5000 0051



Voltage sensing and power supply tap

Use

It allows connection of 2x ≤1.5 mm² voltage sensing or power cables.

This single-pole voltage sensing tap allows the connection of 2 x ≤1.5 mm² voltage sensing or power cables to any SIRCO MV power terminal without reducing its connection capacity.

For SIRCO MV

Rating (A)	Pack	Reference
100 ... 160	2 pieces	1399 4006



Characteristics

Characteristics according to IEC 60947-3

Thermal current I_{th} (40 °C)	SIRCO M - from 16 to 125 A								
	16 A	20 A	25 A	32 A	40 A	63 A	80 A	100 A	125 A
Frame size	M1	M1	M1	M1	M1	M2	M2	M3	M3
Rated insulation voltage U_i (V)	800	800	800	800	800	800	800	800	800
Rated impulse withstand voltage U_{imp} (kV)	8	8	8	8	8	8	8	8	8

Rated operational currents I_e (A)

Rated voltage	Utilisation category	A/B ⁽¹⁾	A/B ⁽¹⁾	A/B ⁽¹⁾	A/B ⁽¹⁾	A/B ⁽¹⁾	A/B ⁽¹⁾	A/B ⁽¹⁾	A/B ⁽¹⁾	A/B ⁽¹⁾
415 VAC	AC-20 A / AC-20 B	16/16	20/20	25/25	32/32	40/40	63/63	80/80	100/100	125/125
415 VAC	AC-21 A / AC-21 B	16/16	20/20	25/25	32/32	40/40	63/63	80/80	100/100	125/125
415 VAC	AC-22 A / AC-22 B	16/16	20/20	25/25	32/32	40/40	63/63	80/80	100/100	125/125
415 VAC	AC-23 A / AC-23 B	16/16	20/20	25/25	32/32	40/40	63/63	80/80	100/100	125/125
500 VAC	AC-20 A / AC-20 B	16/16	20/20	25/25	32/32	40/40	63/63	80/80	100/100	125/125
500 VAC	AC-21 A / AC-21 B	16/16	20/20	25/25	32/32	40/40	63/63	80/80	100/100	125/125
500 VAC	AC-22 A / AC-22 B	16/16	20/20	25/25	32/32	40/40	63/63	80/80	100/100	125/125
500 VAC	AC-23 A / AC-23 B	16/16	20/20	25/25	25/25	25/25	63/63	63/63	80/80	100/100
690 VAC	AC-20 A / AC-20 B	16/16	20/20	25/25	32/32	40/40	63/63	80/80	100/100	125/125
690 VAC	AC-21 A / AC-21 B	16/16	20/20	25/25	32/32	40/40	63/63	80/80	100/100	125/125
690 VAC	AC-22 A / AC-22 B	16/16	20/20	25/25	32/32	32/40	40/63	63/80	80/100	100/125
690 VAC	AC-23 A / AC-23 B	16/16	20/20	25/25	25/25	25/25	40/40	40/40	63/63	63/63
110 VDC	DC-20 A / DC-20 B	16/16	20/20	25/25	32/32	40/40	63/63	80/80	100/100	125/125
110 VDC	DC-21 A / DC-21 B	16/16 ⁽²⁾	20/20 ⁽²⁾	25/25 ⁽²⁾	32/32 ⁽²⁾	40/40 ⁽²⁾	63/63 ⁽²⁾	80/80 ⁽²⁾	100/100 ⁽²⁾	125/125 ⁽²⁾
250 VDC	DC-20 A / DC-20 B	16/16	20/20	25/25	32/32	40/40	63/63	80/80	100/100	125/125
250 VDC	DC-21 A / DC-21 B	16/16 ⁽³⁾	20/20 ⁽³⁾	25/25 ⁽³⁾	32/32 ⁽³⁾	40/40 ⁽³⁾	63/63 ⁽³⁾	80/80 ⁽³⁾	100/100 ⁽³⁾	125/125 ⁽³⁾
400 VDC	DC-20 A / DC-20 B	16/16	20/20	25/25	32/32	40/40	63/63	80/80	100/100	125/125
400 VDC	DC-21 A / DC-21 B	16/16 ⁽⁴⁾	20/20 ⁽⁴⁾	25/25 ⁽⁴⁾	25/25 ⁽⁴⁾	25/25 ⁽⁴⁾	40/40 ⁽⁴⁾	40/40 ⁽⁴⁾	63/63 ⁽⁴⁾	63/63 ⁽⁴⁾

Operational power in AC-23 (kW)

400 VAC without pre-break AC(kW) ⁽⁵⁾	7.5	9	11	15	18.5	30	37	45	55
500 VAC without pre-break AC(kW) ⁽⁵⁾	7.5	9	11	15	18.5	30	37	45	55
690 VAC without pre-break AC(kW) ⁽⁵⁾	7.5	11	15	15	15	30	37	45	55

Fuse protected short-circuit withstand (kA rms prospective)⁽⁶⁾

Prospective short-circuit current (kA rms)	50	50	50	50	50	50	50	25	25
Associated fuse rating (A)	16	20	25	32	40	63	80	100	125

Circuit breaker protected short-circuit withstand with any circuit breaker that ensures tripping in less than 0.3s

Rated short-time withstand current 0.3s. I_{cw} (kA rms)	2.5	2.5	2.5	2.5	2.5	3	3	5	5
--	-----	-----	-----	-----	-----	---	---	---	---

Short-circuit capacity (without protection)

Rated short-time withstand current 1s. I_{cw} (kA rms)	1.26	1.26	1.26	1.26	1.26	1.5	1.5	2.75	2.75
Rated peak withstand current (kA peak) ⁽⁶⁾	6	6	6	6	6	9	9	12	12

Connection

Maximum Cu cable cross-section (mm ²)	1.5	1.5	1.5	1.5	1.5	2.5	2.5	10	10
Maximum Cu cable cross-section (mm ²)	16	16	16	16	16	35	35	70	70
Tightening torque min/max (Nm)	2 / 2.2	2 / 2.2	2 / 2.2	2 / 2.2	2 / 2.2	3.5 / 3.85	3.5 / 3.85	4/4.4	4/4.4

Mechanical characteristics

Durability (number of operating cycles)	100 000	100 000	100 000	100 000	100 000	100 000	100 000	100 000	100 000
Operating effort - 3 pole device (Nm)	1	1	1	1	1	1.4	1.4	1.6	1.6
Operating effort - 4 pole device (Nm)	1.2	1.2	1.2	1.2	1.2	1.6	1.6	2	2
Weight of a 3 pole device (kg)	0.18	0.18	0.18	0.18	0.18	0.27	0.27	0.55	0.55
Weight of a 4 pole device (kg)	0.23	0.23	0.23	0.23	0.23	0.33	0.33	0.72	0.72
Weight of a 6 pole device (kg)	0.40	0.40	0.40	0.40	0.40	0.59	0.59	1.30	1.30
Weight of a 8 pole device (kg)	0.50	0.50	0.50	0.50	0.50	0.69	0.69	1.65	1.65
Weight of a 3 pole device (kg)	0.40	0.40	0.40	0.40	0.40	0.59	0.59	1.30	1.30
Weight of a 4 pole device (kg)	0.50	0.50	0.50	0.50	0.50	0.69	0.69	1.65	1.65

(1) Category with index A = frequent operation -
Category with index B = infrequent operation.

(2) One pole per polarity.

(3) 3-pole device with 2 poles in series for the "+" and 1 pole for the "-".

(4) 4-pole device with 2 poles in series per polarity.

(5) The power value is given for information only, the current values vary from one manufacturer to another.

(6) For a rated operational voltage $U_e = 415$ VAC.

Characteristics

Characteristics according to IEC 60947-3

		SIRCO MV - from 100 to 160 A		
Thermal current I_{th} (40 °C)		100 A	125 A	160 A
Rated insulation voltage U_i (V)		800	800	800
Rated impulse withstand voltage U_{imp} (kV)		8	8	8
Rated operational currents I_e (A)				
Rated voltage	Utilisation category	A/B ⁽¹⁾	A/B ⁽¹⁾	A/B ⁽¹⁾
415 VAC	AC-20 A / AC-20 B	100/100	125/125	160/160
415 VAC	AC-21 A / AC-21 B	100/100	125/125	160/160
415 VAC	AC-22 A / AC-22 B	100/100	125/125	160/160
415 VAC	AC-23 A / AC-23 B	100/100	125/125	125/160
500 VAC	AC-20 A / AC-20 B	100/100	125/125	160/160
500 VAC	AC-21 A / AC-21 B	100/100	125/125	160/160
500 VAC	AC-22 A / AC-22 B	100/100	125/125	125/160
500 VAC	AC-23 A / AC-23 B	80/80	100/100	100/100
690 VAC	AC-20 A / AC-20 B	100/100	125/125	160/160
690 VAC	AC-21 A / AC-21 B	100/100	125/125	160/160
690 VAC	AC-22 A / AC-22 B	63/80	80/100	100/125
690 VAC	AC-23 A / AC-23 B	63/63	80/80	80/80
110 VDC	DC-20 A / DC-20 B	100/100	125/125	160/160
110 VDC	DC-21 A / DC-21 B	100/100 ⁽²⁾	125/125 ⁽²⁾	160/160 ⁽²⁾
250 VDC	DC-20 A / DC-20 B	100/100	125/125	160/160
250 VDC	DC-21 A / DC-21 B	100/100 ⁽³⁾	125/125 ⁽³⁾	160/160 ⁽³⁾
400 VDC	DC-20 A / DC-20 B	100/100	125/125	160/160
400 VDC	DC-21 A / DC-21 B	100/100 ⁽⁴⁾	125/125 ⁽⁴⁾	160/160 ⁽⁴⁾
Operational power in AC-23 (kW)				
400 VAC without pre-break AC(kW) ⁽⁵⁾		45	55	75
500 VAC without pre-break AC(kW) ⁽⁵⁾		45	55	75
690 VAC without pre-break AC(kW) ⁽⁵⁾		45	75	75
Fuse protected short-circuit withstand (kA rms prospective)⁽⁶⁾				
Prospective short-circuit current (kA rms)		100	65	50
Associated fuse rating (A)		100	125	160
Circuit breaker protected short-circuit withstand with any circuit breaker that ensures tripping in less than 0.3s				
Rated short-time withstand current 0.3s. I_{cw} (kA rms)		7	7	7
Short-circuit capacity (without protection)				
Rated short-time withstand current 1s. I_{cw} (kA rms)		4	4	4
Rated peak withstand current (kA peak) ⁽⁶⁾		12	12	12
Connection				
Maximum Cu cable cross-section (mm ²)		10	10	10
Maximum Cu cable cross-section (mm ²)		70	70	70
Tightening torque min/max (Nm)		4 / 4.4	4 / 4.4	4 / 4.4
Mechanical characteristics				
Durability (number of operating cycles)		50 000	50 000	50 000
Operating effort - 3 pole device (Nm)		4	4	4
Operating effort - 4 pole device (Nm)		4.2	4.2	4.2
Weight of a 3 pole device (kg)		0.68	0.68	0.68
Weight of a 4 pole device (kg)		0.85	0.85	0.85

(1) Category with index A = frequent operation - Category with index B = infrequent operation.

(2) One pole per polarity.

(3) 2 poles in series for the "+" and 1 pole for the "-".

(4) 2 poles in series per polarity.

(5) The power value is given for information only, the current values vary from one manufacturer to another.

(6) For a rated operational voltage $U_e = 415$ VAC.

SIRCO M and MV

Universal load break switches

from 16 to 160 A

Dimensions

SIRCO M1 and M2 16 to 80 A

Toggle operation

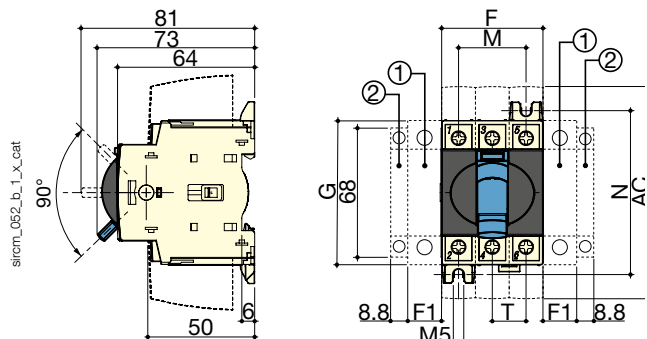

1. Location for: 1 switched fourth pole module (1 per device max.) or 1 unswitched neutral pole or 1 protective earth module or 1 auxiliary contact.
 2. Position for 1 auxiliary contact module only.

Note: max 2 additional blocks.

Direct operation with handle

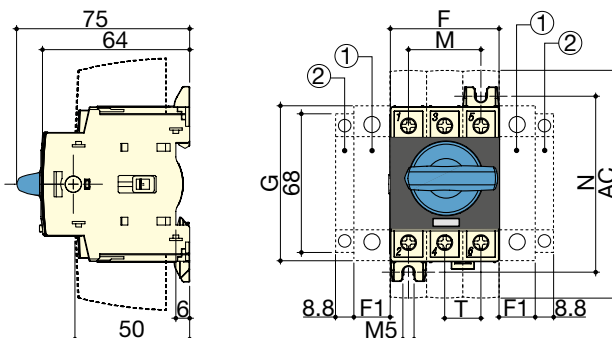

1. Location for: 1 switched fourth pole module (1 per device max.) or 1 unswitched neutral pole or 1 protective earth module or 1 auxiliary contact.
 2. Position for 1 auxiliary contact module only.

Note: max 2 additional blocks.

External front operation

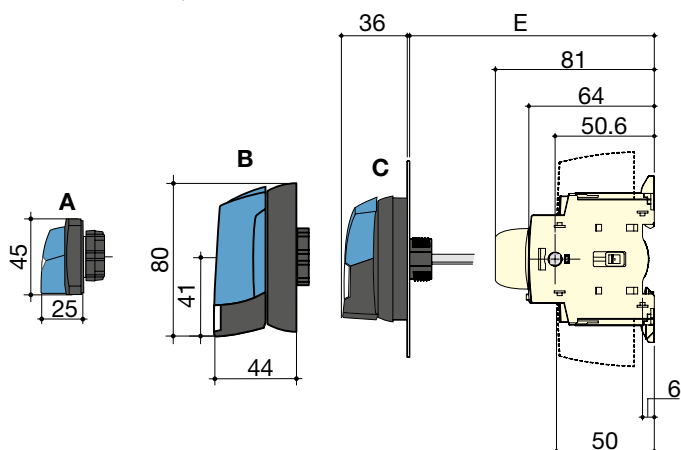

1. Location for: 1 switched fourth pole module (1 per device max.) or 1 unswitched neutral pole or 1 protective earth module or 1 auxiliary contact.
 2. Position for 1 auxiliary contact module only.

Note: max 2 additional blocks.

External side operation

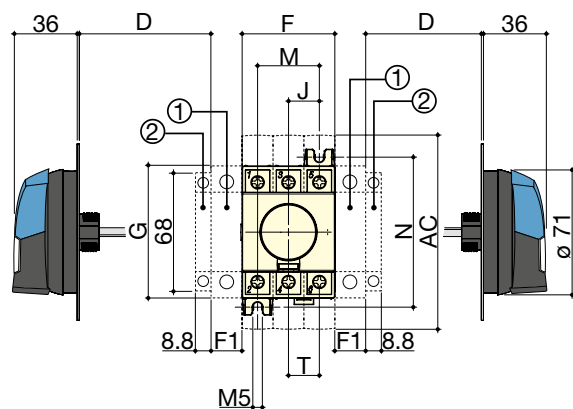

- A. S000 Handle
 B. S01 Handle
 C. S00 Handle.

Rating (A) / Frame size	Overall dimensions				Terminal shrouds		Switch body				Switch mounting		Connection
	D min	D max	E min	E max	AC	F	F1	G	J	M	N	T	
16 ... 40 / M1	30	235	100	372	110	45	15	68	15	30	75	15	
63 ... 80 / M2	30	235	100	372	110	52.5	17.5	76	17.5	35	85	17.5	

SIRCO M1 and M2 16 to 80 A (continued)

Direct front operation for
6/8-pole load break switches or 3/4-pole changeover switches

External front operation for 6/8-pole load break switches or
3/4-pole changeover switches

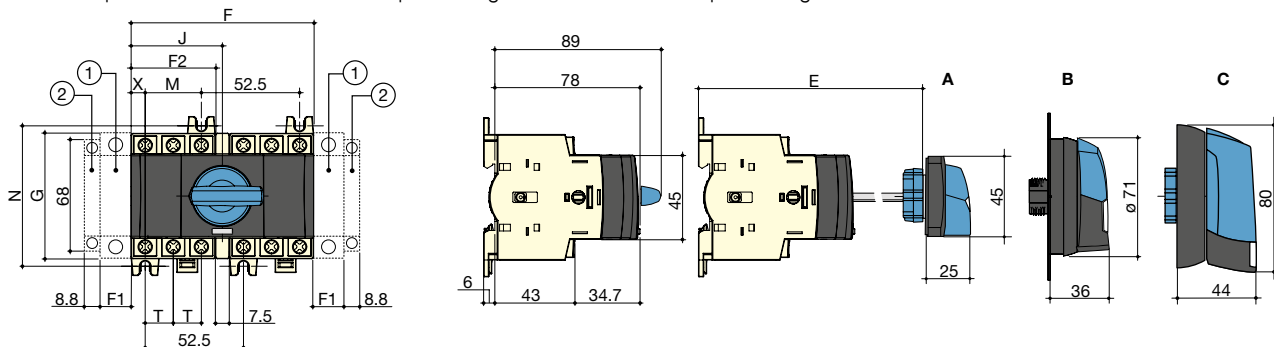

1. Location for: 1 switched fourth pole module (1 per device max.) or 1 unswitched neutral pole or 1 protective earth module or 1 auxiliary contact.
2. Position for 1 auxiliary contact module only.

- A. S000 handle
B. S00 handle
C. S01 handle

Note: max 2 additional blocks.

Rating (A) / Frame size	Overall dimensions		Switch body					Switch mounting		Connection	
	E min	E max	F	F1	F2	G	J	M	N	T	X
16 ... 40 / M1	105	372	97.5	15	45	68	48.75	30	75	15	7.5
63 ... 80 / M2	105	372	105	17.5	52.5	76	52.5	35	85	17.5	8.75

SIRCO M3 100 to 125 A

Direct operation with handle

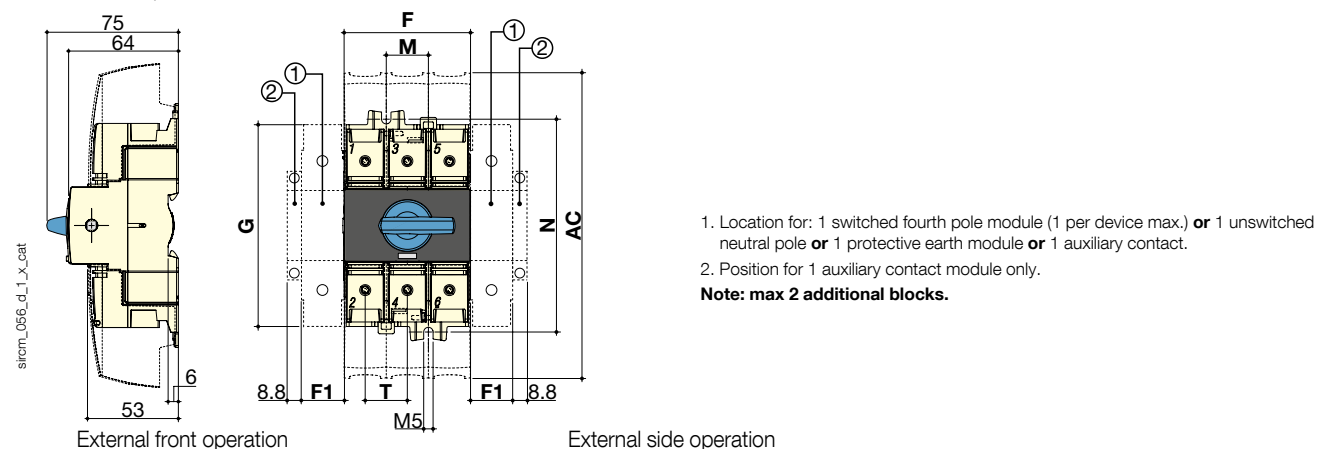

1. Location for: 1 switched fourth pole module (1 per device max.) or 1 unswitched neutral pole or 1 protective earth module or 1 auxiliary contact.
2. Position for 1 auxiliary contact module only.

Note: max 2 additional blocks.

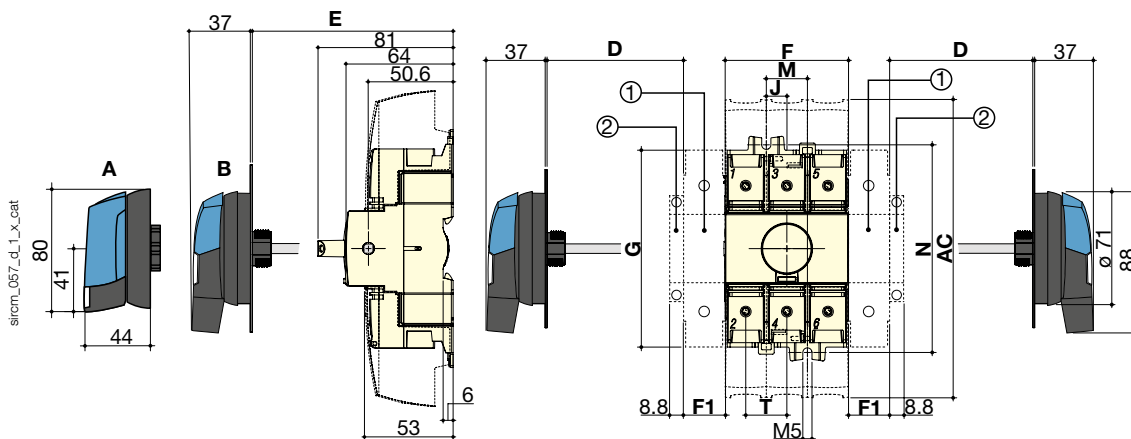

1. Location for: 1 switched fourth pole module (1 per device max.) or 1 unswitched neutral pole or 1 protective earth module or 1 auxiliary contact.
2. Position for 1 auxiliary contact module only.

- A. S01 handle
B. S00 handle

Note: max 2 additional blocks.

Rating (A) / Frame size	Overall dimensions				Terminal shrouds	Switch body				Switch mounting		Connection
	D min	D max	E min	E max	AC	F	F1	G	J	M	N	T
100 ... 125 / M3	30	201	100	372	189	78	26	124.6	13	26	131.4	26

SIRCO M and MV

Universal load break switches

from 16 to 160 A

Dimensions (continued)

SIRCO M3 6/8 P and changeover switch M3 100 to 125 A

Direct front operation for 3/4 pole changeover switches

External front operation for 3 and 4 pole changeover switches

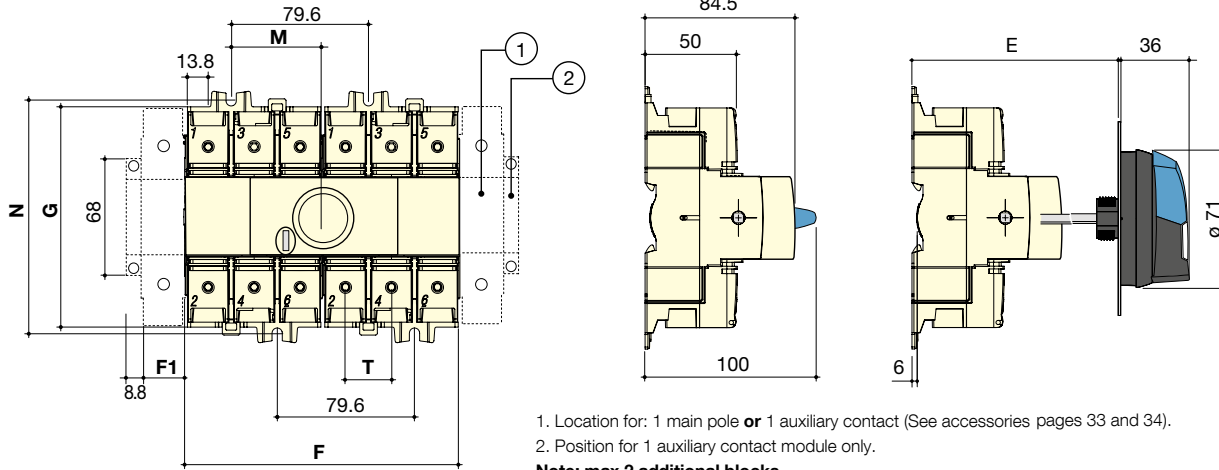

sirco_m183_e_1_x_cat

Rating (A) / Frame size	Overall dimensions		Switch body			Switch mounting		Connection
	E min	E max	F	F1	G	M	N	
100 ... 125 / M3	105	372	159	26	124.5	52.8	131.5	26

SIRCO MV 100 to 160 A

Direct front operation

External front operation

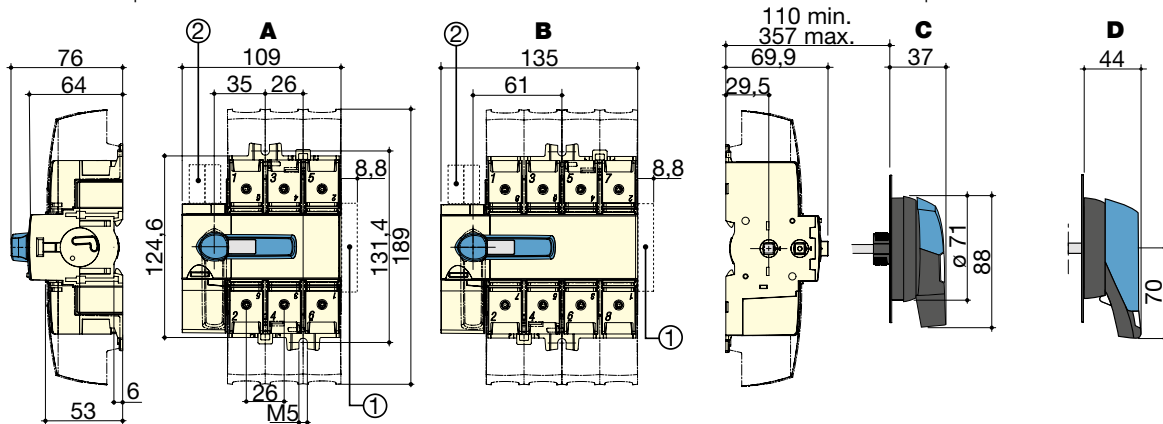

A. 3 poles
B. 4 poles

C. S0 type handle
D. S1 type handle

1. Maximum 4 "M" type auxiliary contacts
2. Maximum 2 "U" type auxiliary contacts

sirco_mv100_c_1_x_cat

External side operation

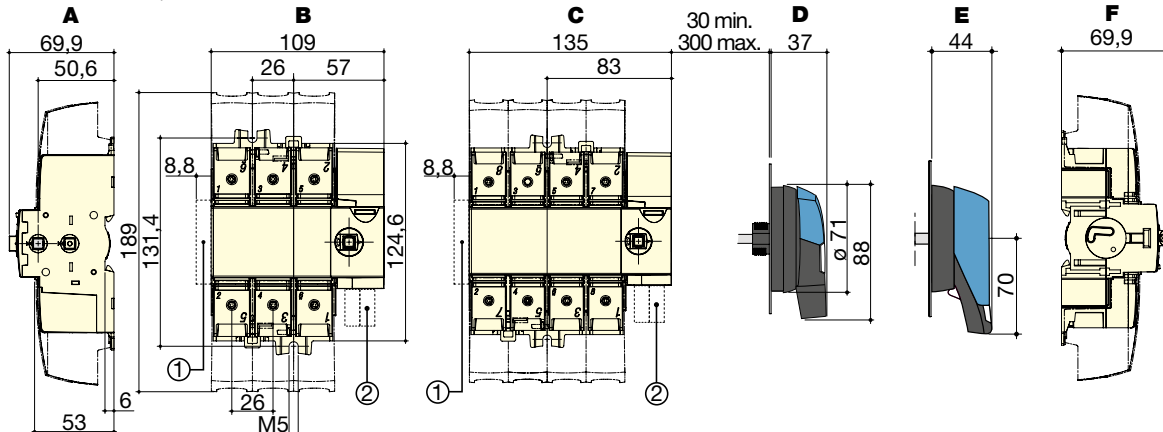

A. Right side operation
B. 3 poles
C. 4 poles

D. S0 type handle
E. S1 type handle
F. Left side operation

1. Maximum 4 "M" type auxiliary contacts
2. Maximum 2 "U" type auxiliary contacts

sirco_mv100_d_1_x_cat

Dimensions for external handles

SIRCO M1 and M2

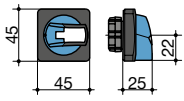
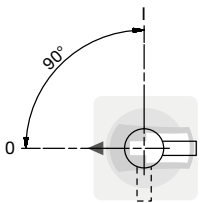
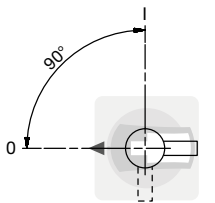
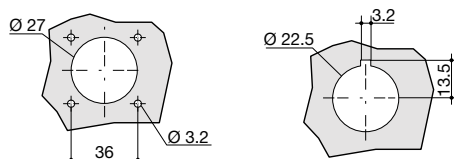
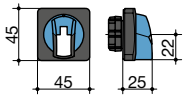
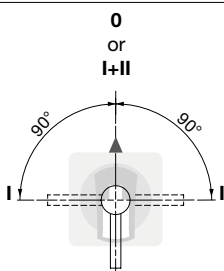
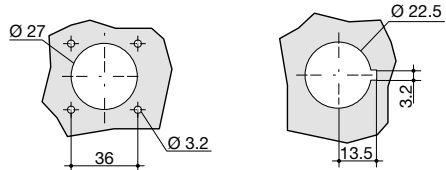
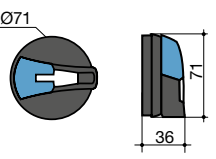
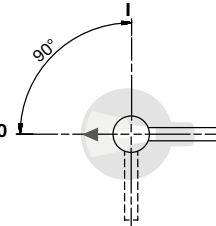
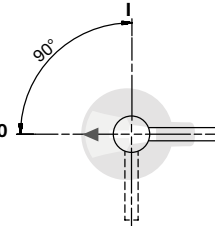
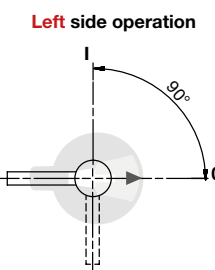
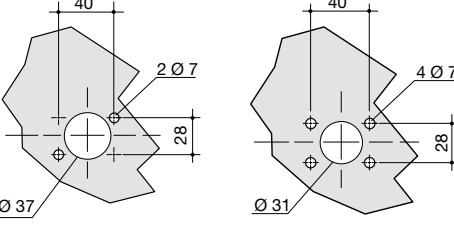
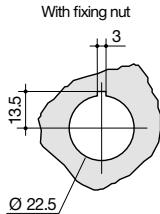
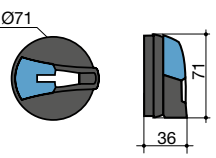
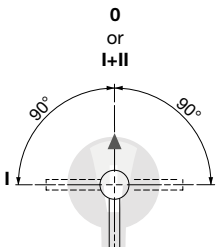
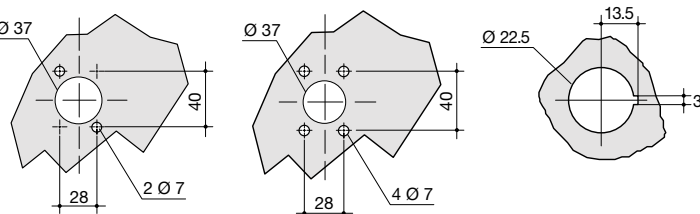
<p>Handle type</p> <p>S000 type Load break switches</p> 	<p>Front operation Direction of operation</p> 	<p>Side operation Direction of operation</p> <p>Right side operation</p> 	<p>Door drilling</p> <p>With 4 fixing screws With fixing nut</p> 	
<p>Handle type</p> <p>S000 type Transfer switches I-0-II and I - I+II - II</p> 	<p>Front operation Direction of operation</p> <p>0 or I+II</p> 		<p>Door drilling</p> <p>With 4 fixing screws With fixing nut</p> 	
<p>Handle type</p> <p>S00 type Load break switches</p> 	<p>Front operation Direction of operation</p> 	<p>Side operation Direction of operation</p> <p>Right side operation</p>  <p>Left side operation</p> 	<p>Door drilling</p> <p>IP55 with 2 fixing clips IP65 with 4 fixing screws</p>  <p>With fixing nut</p> 	
<p>Handle type</p> <p>S00 type Transfer switches I-0-II and I - I+II - II</p> 	<p>Front operation Direction of operation</p> <p>0 or I+II</p> 	<p>Door drilling</p> <p>IP55 with 2 fixing clips IP65 with 4 fixing screws With fixing nut</p> 		

poign_016_a_1_gb_cat

poign_017_b_1_gb_cat

poign_024_a_1_gb_cat

poign_025_b_1_gb_cat

SIRCO M and MV

Universal load break switches

from 16 to 160 A

Dimensions for external handles

SIRCO M1 and M2 - 3/4 P and 6/8 P

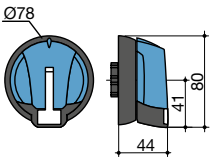
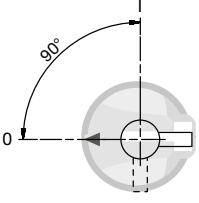
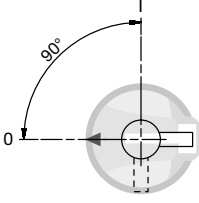
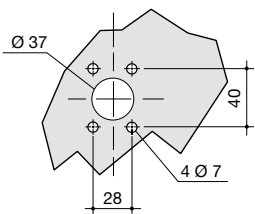
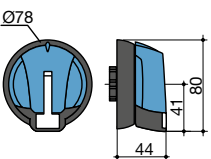
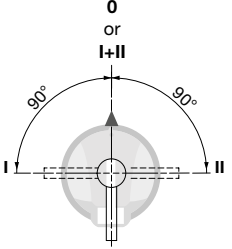
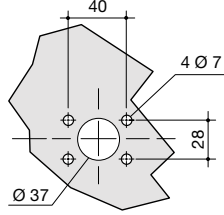
Handle type	Front operation Direction of operation	Side operation Direction of operation	Door drilling
S01 type Load break switches 		Right side operation 	IP65 with 4 fixing screws 
S01 type Transfer switches I-0-II and I - I+II - II 	Front operation Direction of operation 		IP65 with 4 fixing screws 

poign_018_a_1_gb_cat

poign_019_b_1_gb_cat

SIRCO M3

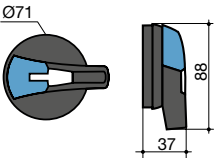
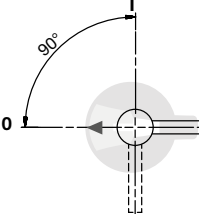
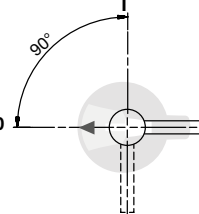
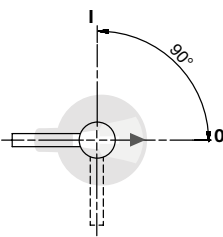
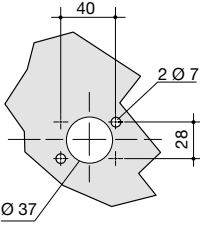
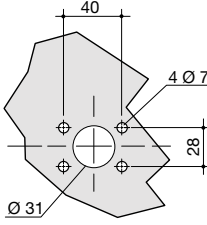
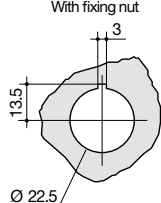
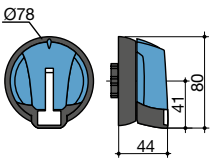
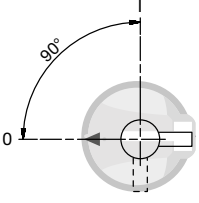
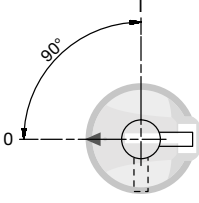
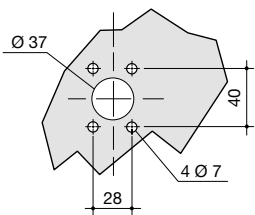
Handle type	Front operation Direction of operation	Side operation Direction of operation	Door drilling
S0 type Load break switches 		Right side operation  Left side operation 	IP55 with 2 fixing clips  IP65 with 4 fixing screws  With fixing nut 
S01 type Load break switches 		Right side operation 	IP65 with 4 fixing screws 

poign_026_a_1_gb_cat

poign_018_a_1_gb_cat

SIRCO MV

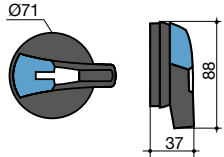
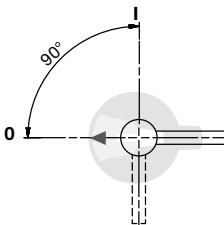
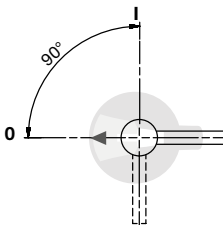
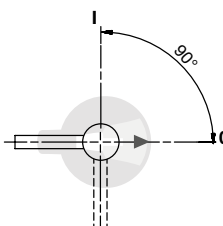
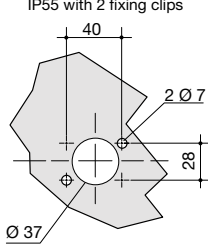
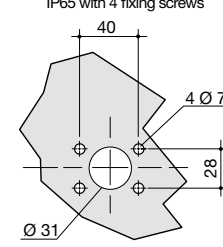
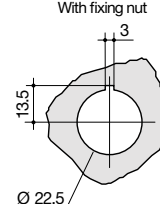
Handle type	Front operation Direction of operation	Side operation Direction of operation	Door drilling	
S0 type Load break switches 		Right side operation  Left side operation 	IP55 with 2 fixing clips  IP65 with 4 fixing screws  With fixing nut 	

poign_026_a_1_gb_cat

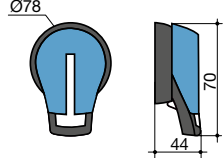
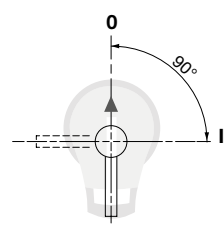
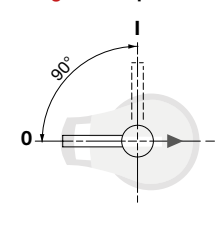
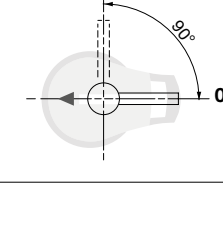
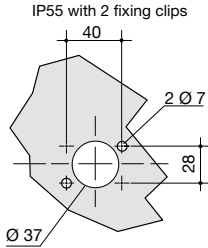
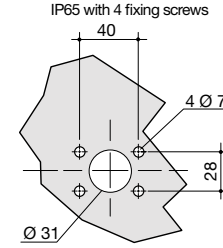
Handle type	Front operation Direction of operation	Side operation Direction of operation	Door drilling	
S1 type Load break switches 		Right side operation  Left side operation 	IP55 with 2 fixing clips  IP65 with 4 fixing screws 	

poign_027_a_1_gb_cat

SIRCO

Load break switches for power distribution from 125 to 5000 A



Function

SIRCO and **SIRCO AC** are manually or remotely operated multipolar load break switches. They make and break under load conditions and provide safe isolation. SIRCO are designed for 415 VAC and DC low voltage electrical circuits. SIRCO AC are designed for heavy duty applications up to 690 VAC - AC 23.

General characteristics

- Double positive break indication given through a position indication window, located directly on the product, and by the operating handle.
- Severe load duty categories (AC-22 and AC-23).
- High resistance to damp heat (supplied "tropicalised").

Advantages

Reliability and performance

The double breaking per pole, achieved through its sliding bar contact system, is a proven design that offers very high durability and short-circuit withstand. Improved breaking performance with quick opening and rapid closure.

Safety of property and personnel

The position indicator is located directly on the sliding bar contact mechanism, ensuring it can be seen in all circumstances.

The use of glass fibre reinforced polyester gives the SIRCO and SIRCO AC both high mechanical and thermal resistance.

Simplicity

The standardisation of the SIRCO and SIRCO AC range and its wide choice of common accessories enable:

- Simple mounting.
- Reduced stock management and storage costs.

Easy to install

The outdoors ranges are easy to install thanks to:

- A good centre-to-centre distance (up to 120 mm).
- Connection up to 6 x 185 mm².
- Connection accessories which facilitate both flat and edgewise connections.

The solution for

- > Main switchboard
- > Distribution panel
- > Emergency breaking
- > Network coupling
- > Local safety breaking



Strong points

- > Reliability and performance
- > Safety of property and personnel
- > Simplicity
- > Easy to install

Compliance with standards

- > IEC 60947-3



Approvals and certifications⁽¹⁾



BUREAU VERITAS

⁽¹⁾ Product reference on request.

Enclosures

- > The SIRCO and SIRCO AC range can be easily fitted in our enclosures and cabinets designed for electrical distribution.



What you need to know

- In front **direct** or **external** operation, SIRCO is available in 3 and 4-pole versions from 125 to 5000 A.
- It can be ordered in 6 or 8-pole versions from 125 to 1600 A.
- SIRCO is available in a polyester or sheet metal enclosure from 125 to 1250 A.

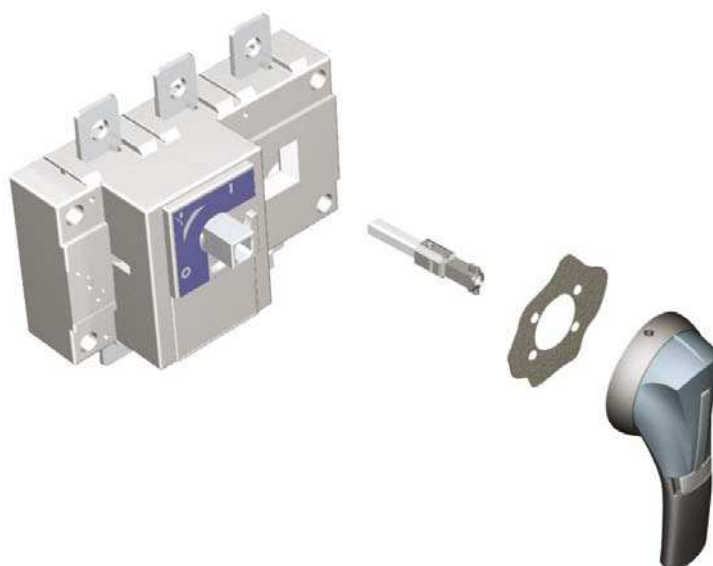

sirco_372_b_1_cat

For ratings 2000, 2500 and 3200A, a copper **bar connection kit** enables the connection between the two power terminals of one pole.

Flat connection
top or bottom

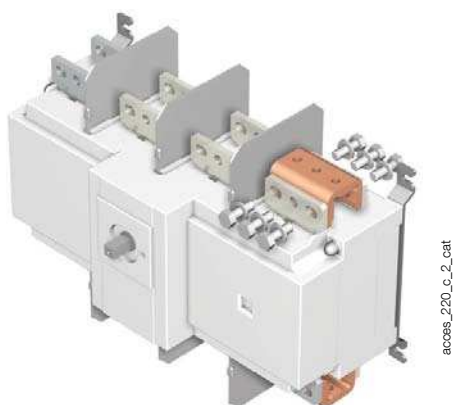

access_220_c_2_cat

Edgewise connection
top or bottom

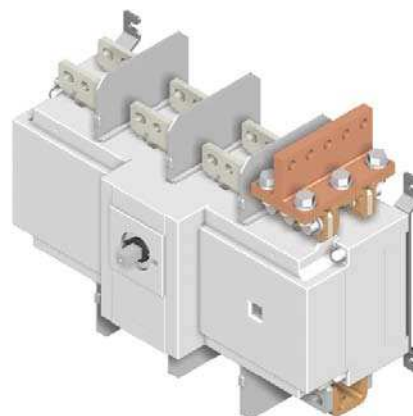

access_223_b_2_cat

SIRCO - References

Standard applications - Front operation - 3 & 4-pole

Rating (A) / Frame size	No. of poles	Switch body ⁽¹⁾	Direct handle	External handle	Shaft for external handle	Auxiliary contact	Terminal shrouds	Terminal screens
125 A / B3	3 P	2600 3014	B1 type Black 2699 5042 ⁽²⁾ Red 2699 5043				3 P 2694 3014 ⁽³⁾ 4 P 2694 4014 ⁽³⁾	3 P 2698 3012 ⁽³⁾ 4 P 2698 4012 ⁽³⁾
	4 P	2600 4014						
160 A / B3	3 P	2600 3017					3 P 2694 3021 ⁽³⁾ 4 P 2694 4021 ⁽³⁾	3 P 2698 3020 ⁽³⁾ 4 P 2698 4020 ⁽³⁾
	4 P	2600 4017						
200 A / B4	3 P	2600 3021					3 P 2694 3051 ⁽³⁾ 4 P 2694 4051 ⁽³⁾	3 P 2698 3050 ⁽³⁾ 4 P 2698 4050 ⁽³⁾
	4 P	2600 4021						
250 A / B4	3 P	2600 3026		S2 type Black IP55 1421 2111 ⁽²⁾ Black IP65 1423 2111 Red IP65 1424 2111	200 mm 1400 1020 320 mm 1400 1032 ⁽²⁾ 500 mm 1400 1050		3 P 2694 3051 ⁽³⁾ 4 P 2694 4051 ⁽³⁾	3 P 2698 3050 ⁽³⁾ 4 P 2698 4050 ⁽³⁾
	4 P	2600 4026						
315 A / B5	3 P	2600 3032	B2 type Black 2699 5052 ⁽²⁾ Red 2699 5053				3 P 2694 3051 ⁽³⁾ 4 P 2694 4051 ⁽³⁾	3 P 2698 3050 ⁽³⁾ 4 P 2698 4050 ⁽³⁾
	4 P	2600 4032						
400 A / B5	3 P	2600 3041					3 P 2694 3051 ⁽³⁾ 4 P 2694 4051 ⁽³⁾	3 P 2698 3050 ⁽³⁾ 4 P 2698 4050 ⁽³⁾
	4 P	2600 4041						
500 A / B5	3 P	2600 3051					3 P 2694 3051 ⁽³⁾ 4 P 2694 4051 ⁽³⁾	3 P 2698 3050 ⁽³⁾ 4 P 2698 4050 ⁽³⁾
	4 P	2600 4051						
630 A / B5	3 P	2600 3064					3 P 2694 3051 ⁽³⁾ 4 P 2694 4051 ⁽³⁾	3 P 2698 3050 ⁽³⁾ 4 P 2698 4050 ⁽³⁾
	4 P	2600 4064						
800 A / B6	3 P	2600 3081				1 st NO/NC contact 2699 0031 2 nd NO/NC contact 2699 0032	3 P 2698 3080 ⁽³⁾ 4 P 2698 4080 ⁽³⁾	3 P 2698 3080 ⁽³⁾ 4 P 2698 4080 ⁽³⁾
	4 P	2600 4081						
1000 A / B6	3 P	2600 3099					3 P 2698 3080 ⁽³⁾ 4 P 2698 4080 ⁽³⁾	3 P 2698 3080 ⁽³⁾ 4 P 2698 4080 ⁽³⁾
	4 P	2600 4099						
CD 1250 A / B6	3 P	2600 3119		Type S4 Black IP65 1443 3111 ⁽²⁾ Red IP65 1444 3111	200 mm 1401 1520 320 mm 1401 1532 ⁽²⁾ 400 mm 1401 1540		3 P 2698 3120 ⁽³⁾ 4 P 2698 4120 ⁽³⁾	3 P 2698 3120 ⁽³⁾ 4 P 2698 4120 ⁽³⁾
	4 P	2600 4119						
1250 A / B7	3 P	2600 3121	C2 type Black 2799 7012 ⁽²⁾ Red 2799 7013				3 P 2698 3120 ⁽³⁾ 4 P 2698 4120 ⁽³⁾	3 P 2698 3120 ⁽³⁾ 4 P 2698 4120 ⁽³⁾
	4 P	2600 4121						
1600 A / B7	3 P	2600 3161					3 P 2698 3120 ⁽³⁾ 4 P 2698 4120 ⁽³⁾	3 P 2698 3120 ⁽³⁾ 4 P 2698 4120 ⁽³⁾
	4 P	2600 4161						
1800 A / B7	3 P	2600 3181					3 P 2698 3120 ⁽³⁾ 4 P 2698 4120 ⁽³⁾	3 P 2698 3120 ⁽³⁾ 4 P 2698 4120 ⁽³⁾
	4 P	2600 4181						
2000 A / B8	3 P	2600 3200		V2 type Black IP65 2799 7136 ⁽²⁾ Red IP65 2799 7134	200 mm 2799 3015 320 mm 2799 3018 ⁽²⁾ 450 mm 2799 3019		3 P 2698 3200 ⁽³⁾ 4 P 2698 4200 ⁽³⁾	3 P 2698 3200 ⁽³⁾ 4 P 2698 4200 ⁽³⁾
	4 P	2600 4200						
2500 A / B8	3 P	2600 3250					3 P 2698 3200 ⁽³⁾ 4 P 2698 4200 ⁽³⁾	3 P 2698 3200 ⁽³⁾ 4 P 2698 4200 ⁽³⁾
	4 P	2600 4250						
3200 A / B8	3 P	2600 3320					3 P 2698 3200 ⁽³⁾ 4 P 2698 4200 ⁽³⁾	3 P 2698 3200 ⁽³⁾ 4 P 2698 4200 ⁽³⁾
	4 P	2600 4320						
4000 A / B9	3 P	2600 3401	V0 type Black 2799 7072 ⁽²⁾	V0 type Black IP65 2799 7155 ⁽²⁾		1 st /2 nd NO/NC contact included	3 P 2698 3200 ⁽³⁾ 4 P 2698 4200 ⁽³⁾	3 P 2698 3200 ⁽³⁾ 4 P 2698 4200 ⁽³⁾
	4 P	2600 4401						
5000 A / B9	3 P	2600 3500					3 P 2698 3200 ⁽³⁾ 4 P 2698 4200 ⁽³⁾	3 P 2698 3200 ⁽³⁾ 4 P 2698 4200 ⁽³⁾
	4 P	2600 4500						

(1) Device available enclosed (see "Enclosed load break switches" page 726).

(2) Standard.

(3) Top or bottom.

SIRCO AC - References

Heavy duty applications - Front operation 3 & 4 pole

Rating (A) / Frame size	No. of poles	Switch body	Direct handle	External handle	Shaft for external handle	Auxiliary contact	Terminal shrouds	Terminal screens
200 A / B4	3 P	26AC 3020	J1 type Black 1112 1111 ⁽¹⁾ J1 type Red 1113 1111	S2 type Black IP65 1421 2111 ⁽¹⁾ Black IP65 1423 2111 Red IP65 1424 2111	200 mm 1400 1020 320 mm 1400 1032 ⁽¹⁾ 500 mm 1400 1050		3P 2694 3021 ⁽²⁾⁽³⁾ 4 P 2694 4021 ⁽²⁾⁽³⁾	3P 2698 3020 ⁽³⁾ 4 P 2698 4020 ⁽³⁾
	4 P	26AC 4020						
250 A / B4	3 P	26AC 3025						
	4 P	26AC 4025						
315 A / B4	3 P	26AC 3031						
	4 P	26AC 4031						
400 A / B5	3 P	26AC 3040						
	4 P	26AC 4040						
500 A / B5	3 P	26AC 3050						
	4 P	26AC 4050						
CD 630 A / B5	3 P	26AC 3063						
	4 P	26AC 4063						
630 A / B6	3 P	26AC 3064	J4 type Black 1142 1111 ⁽¹⁾ Red 1143 1111	S4 type Black IP65 1443 3111 ⁽¹⁾ Red IP65 1444 3111	200 mm 1401 1520 320 mm 1401 1532 ⁽¹⁾ 400 mm 1401 1540	1 st contact NO/NC 2699 0031 2 nd contact NO/NC 2699 0032	3P 2694 3051 ⁽²⁾⁽³⁾ 4 P 2694 4051 ⁽²⁾⁽³⁾	3P 2698 3050 ⁽³⁾ 4 P 2698 4050 ⁽³⁾
	4 P	26AC 4064						
800 A / B6	3 P	26AC 3080						
	4 P	26AC 4080						
1000 A / B6	3 P	26AC 3100						
	4 P	26AC 4100						
CD 1250 A / B6	3 P	26AC 3120						
	4 P	26AC 4120						
1250 A / B7	3 P	26AC 3121						
	4 P	26AC 4121						
1600 A / B7	3 P	26AC 3160						
	4 P	26AC 4160						
2000 A / B8	3 P	26AC 3200	S5 type Black 2799 7042 ⁽¹⁾ Red 2799 7043	S5 type Black IP65 1453 8111 ⁽¹⁾ Red IP65 1454 8111	200 mm 2799 3015 320 mm 2799 3018 ⁽¹⁾ 450 mm 2799 3019		3P 2698 3200 ⁽²⁾⁽³⁾ 4 P 2698 4200 ⁽²⁾⁽³⁾	
	4 P	26AC 4200						
4000 A / B9	3 P	26AC 3400	V0 type Black 2799 7072 ⁽¹⁾	V0 type Black 2799 7155 ⁽¹⁾		1 st / 2 nd included	3/4P 1509 4200 ⁽⁴⁾	
	4 P	26AC 4400						

(1) Standard.

(2) Mandatory for voltage greater than 415 VAC.

(3) Top or bottom.

(4) Top and bottom.

SIRCO

Load break switches for power distribution
from 125 to 5000 A

SIRCO - References

Standard applications - Front operation - 6 & 8-pole

Rating (A) / Frame size	No. of poles	Switch body	Direct handle	External handle	Shaft for external handle	Auxiliary contact	Terminal shrouds	Terminal screens						
125 A / B3 _{DS}	6 P	2601 6013	Type B3 Black 4199 5012 ⁽¹⁾	S2 type Black IP55 1421 2111 ⁽¹⁾ Red IP65 1424 2111	200 mm 1400 1020 320 mm 1400 1032 ⁽¹⁾		6 P 2694 3014 ⁽²⁾⁽³⁾ 8 P 2694 4014 ⁽²⁾⁽³⁾	6 P 1509 3012 ⁽⁴⁾ 8 P 1509 4012 ⁽⁴⁾						
	8 P	2601 8013												
160 A / B3 _{DS}	6 P	2601 6016												
	8 P	2601 8016												
250 A / B4 _{DS}	6 P	2601 6025	Type C1 Black 2799 7052 ⁽¹⁾ Red 2799 7053	Type S4 Black IP65 1443 3111 ⁽¹⁾ Red IP65 1444 3111	200 mm 1401 1520 320 mm 1401 1532 ⁽¹⁾	1 st NO/NC contact 2699 0061 2 nd NO/NC contact 2699 0062	6 P 2694 3021 ⁽²⁾⁽³⁾ 8 P 2694 4021 ⁽²⁾⁽³⁾	6 P 1509 3025 ⁽⁴⁾ 8 P 1509 4025 ⁽⁴⁾						
	8 P	2601 8025												
400 A / B5 _{DS}	6 P	2601 6040												
	8 P	2601 8040												
630 A / B5 _{DS}	6 P	2601 6063	C2 type Black 2799 7012 ⁽¹⁾ Red 2799 7013	Type V1 Black IP65 2799 7145 ⁽¹⁾	320 mm 2799 3018 ⁽¹⁾		6 P 2694 3051 ⁽²⁾⁽³⁾ 8 P 2694 4051 ⁽²⁾⁽³⁾	6 P 1509 3063 ⁽⁴⁾ 8 P 1509 4063 ⁽⁴⁾						
	8 P	2601 8063												
800 A / B6 _{DS}	6 P	2601 6080												6 P 1509 3080 ⁽⁴⁾ 8 P 1509 4080 ⁽⁴⁾
	8 P	2601 8080												
1000 A / B6 _{DS}	6 P	2601 6100												
	8 P	2601 8100												
1250 A / B7 _{DS}	6 P	2601 6120												
	8 P	2601 8120												
1600 A / B7 _{DS}	6 P	2601 6160						6 P 1509 3160 ⁽⁴⁾ 8 P 1509 4160 ⁽⁴⁾						
	8 P	2601 8160												

(1) Standard.

(2) Top or bottom on the front or rear of the device.

(3) Select 2 sets for front or rear.

(4) Top or bottom at the front of the device.

Accessories

Direct operation handle

SIRCO direct operation handle				
Rating (A) / Frame size	No. of poles	Handle type	Handle colour	Reference
125 ... 160 / B3	3/4 P	B1	Black	2699 5042 ⁽¹⁾
125 ... 160 / B3	3/4 P	B1	Red	2699 5043
125 ... 160 / B3 _{DS}	6/8 P	B3	Black	4199 5012 ⁽¹⁾
200 ... 630 / B4-B5	3/4 P	B2	Black	2699 5052 ⁽¹⁾
200 ... 630 / B4-B5	3/4 P	B2	Red	2699 5053
250 ... 630 / B4 _{DS} -B5 _{DS}	6/8 P	C1	Black	2799 7052 ⁽¹⁾
250 ... 630 / B4 _{DS} -B5 _{DS}	6/8 P	C1	Red	2799 7053
800 ... 3200 / B6...B8	3/4 P	C2	Black	2799 7012 ⁽¹⁾
800 ... 3200 / B6...B8	3/4 P	C2	Red	2799 7013
800 ... 1600 / B6 _{DS} -B7 _{DS}	6/8 P	C2	Black	2799 7012 ⁽¹⁾
800 ... 1600 / B6 _{DS} -B7 _{DS}	6/8 P	C2	Red	2799 7013
4000 ... 5000 / B9	3/4 P	V0	Black	2799 7072 ⁽¹⁾

(1) Standard.



SIRCO AC direct operation handle				
Rating (A) / Frame size	No. of poles	Handle type	Handle colour	Reference
200 ... CD 630 / B4 ... B5	3/4 P	J1	Black	1112 1111 ⁽¹⁾
200 ... CD 630 / B4 ... B5	3/4 P	J1	Red	1113 1111
630 ... 1600 / B6 ... B7	3/4 P	J4	Black	1142 1111 ⁽¹⁾
630 ... 1600 / B6 ... B7	3/4 P	J4	Red	1143 1111
2000 / B8	3/4 P	S5	Black	2799 7042 ⁽¹⁾
2000 / B8	3/4 P	S5	Red	2799 7043
4000 / B9	3/4 P	V0	Black	2799 7072 ⁽¹⁾

(1) Standard.

Door interlocked external operation handle

SIRCO and SIRCO AC external front operation handle						
Rating (A) / Frame size		No. of poles	Handle type	Handle colour	External IP ⁽¹⁾	Reference
SIRCO	SIRCO AC					
125 ... 630 / B3 ... B5	200 ... CD 630 / B4 ... B5	3/4 P	S2	Black	IP55	1421 2111 ⁽²⁾
				Black	IP65	1423 2111
125 ... 160 / B3 _{DS}		6/8 P	S2	Red	IP65	1424 2111
				Black	IP55	1421 2111 ⁽²⁾
250 ... 630 / B4 _{DS} -B5 _{DS}		6/8 P	S4	Black	IP65	1423 2111
				Red	IP65	1424 2111
800 ... 1600 / B6 _{DS} -B7 _{DS}		6/8 P	V1	Black	IP65	1443 3111
				Red	IP65	1444 3111
800 ... 1800 / B6-B7	630 ... 1600 / B6 ... B7	3/4 P	S4	Black	IP65	2799 7145 ⁽²⁾
				Red	IP65	1443 3111
2000 ... 3200 / B8	2000 / B8	3/4 P	V2	Black	IP65	1443 3111 ⁽²⁾
				Red	IP65	2799 7136 ⁽²⁾
4000 ... 5000 / B9	4000 / B9	3/4 P	S5	Black	IP65	2799 7134
				Red	IP65	1453 8111
			V0	Black	IP65	1454 8111
				Black	IP65	2799 7155 ⁽²⁾

(1) IP: protection degree according to IEC 60529 standard.

(2) Standard.

Use

Door interlocked external operation handles include an escutcheon, are padlockable and must be utilised with an extension shaft.



SIRCO

Load break switches for power distribution
from 125 to 5000 A

Accessories (continued)

Shaft for external operation

For 3/4 pole SIRCO and SIRCO AC

Rating (A) / Frame size		Dimension X (mm)	Length (mm)	Reference
SIRCO	SIRCO AC			
125 ... 160 / B3		125 ... 250	200	1400 1020
		125 ... 300	250	1400 1025
		125 ... 370	320	1400 1032
		125 ... 550	500	1400 1050
		125 ... 850	750	1400 1075
200 ... 250 / B4	200 ... 315 / B4	135 ... 265	200	1400 1020
		135 ... 315	250	1400 1025
		135 ... 385	320	1400 1032
		135 ... 565	500	1400 1050
		135 ... 880	750	1400 1075
315 ... 630 / B5	400 ... CD 630 / B5	165 ... 295	200	1400 1020
		165 ... 345	250	1400 1025
		165 ... 415	320	1400 1032
		165 ... 595	500	1400 1050
800 ... 1800 / B6...B7	630 ... 1600 / B6 ... B7	221 ... 343	200	1401 1520
		221 ... 463	320	1401 1532
		221 ... 543	400	1401 1540
2000 ... 3200 / B8	2000 / B8	415 ... 570	200	2799 3015
		415 ... 690	320	2799 3018
		415 ... 820	450	2799 3019
4000 ... 5000 / B9	4000 / B9	550 ... 680	200	2799 3015
		651 ... 921	320	2799 3018

For 6/8-pole SIRCO

Rating (A) / Frame size	Dimension X (mm)	Length (mm)	Reference
125 ... 160 / B3 _{DS}	270 ... 436	200	1400 1020
125 ... 160 / B3 _{DS}	270 ... 556	320	1400 1032
250 ... 630 / B4 _{DS} -B5 _{DS}	221 ... 308	200	1401 1520
250 ... 630 / B4 _{DS} -B5 _{DS}	221 ... 428	320	1401 1532
250 ... 630 / B4 _{DS} -B5 _{DS}	221 ... 508	400	1401 1540

Use

Standard lengths:

- 200 mm
- 250 mm
- 300 mm
- 400 mm
- 500 mm
- 750 mm

Other lengths available:

- please consult us.



access_368_a_1_x_cat

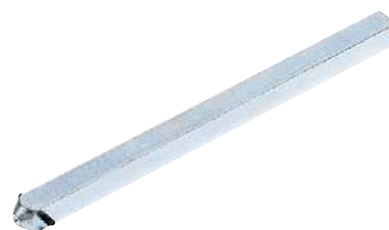

access_144_b_1_cat

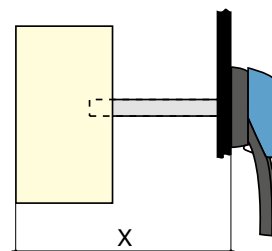

access_202_a_1_x_cat

Alternative handle cover colours

Use

For S type handles.

Handle colour	To be ordered in multiples of	Handle type	Reference
Light grey	50	S2, S3	1401 0001
Dark grey	50	S2, S3	1401 0011
Light grey	50	S4	1401 0031
Dark grey	50	S4	1401 0041



S type cover

access_198_a_2_cat

S type handle adapter

Use

Adds 12 mm to the depth of the handle.

Handle colour	To be ordered in multiples of	External IP ⁽¹⁾	Reference
Black	1	IP65	1493 0000

(1) IP: protection degree according to IEC 60529 standard.



access_187_a_1_cat

Shaft guide for external operation

Use

For use with S-type handles, to guide the shaft extension into the external handle. This accessory enables the handle to engage the extension shaft with a misalignment of up to 15 mm. Recommended for shaft lengths over 320 mm.



access_260_a_2_cat

Description	Reference
Shaft guide	1429 0000

Auxiliary contact

Use

Pre-break and signalling of positions 0 and I:
- 1 to 2 NO/NC auxiliary contacts.
- 1 to 4 NO+NC auxiliary contacts.
- 1 to 2 low level NO/NC auxiliary contacts.

Characteristics

NO/NC A/C: IP2 with front operation.

Connection to the control circuit

6.35 mm fast-on terminal.

Electrical characteristics

30 000 operations.

NO/NC contact for 3/4 pole SIRCO and SIRCO AC		
Rating (A) / Frame size	Position A/C	Reference
125 ... 3200 / B3 ... B8	1 st	2699 0031
125 ... 3200 / B3 ... B8	2 nd	2699 0032
4000 ... 5000 / B9	1 st /2 nd	included

NO/NC contact for 6/8 pole SIRCO		
Rating (A) / Frame size	Position A/C	Reference
125 ... 1600 / B3 _{DS} ... B7 _{DS}	1 st	2699 0061
125 ... 1600 / B3 _{DS} ... B7 _{DS}	2 nd	2699 0062

NO+NC contact for 3/4 pole SIRCO and SIRCO AC		
Rating (A) / Frame size	Position A/C	Reference
125 ... 3200 / B3 ... B8	1 st	2699 0141
125 ... 3200 / B3 ... B8	2 nd /3 rd /4 th	2699 0142

NO/NC low level contact for 3/4 pole SIRCO and SIRCO AC		
Rating (A) / Frame size	Position A/C	Reference
125 ... 3200 / B3 ... B8	1 st	2699 0301
125 ... 3200 / B3 ... B8	2 nd	2699 0302

Characteristics

Rating (A) / Frame size	Contact type	Current nominal (A)	Operating current I _o (A)									
			230 VAC		400 VAC		24 VDC			48 VDC		
			AC-12	AC-13/15	AC-12	AC-13/15	DC-12	DC-13	DC-14	DC-12	DC-13	DC-14
125 ... 3200 / B3 ... B8	NO/NC	16	16	4	12	3	2.5	2.5	1	2.5	1.2	0.2
125 ... 3200 / B3 ... B8	NO + NC	16	16	4	16	3	16	5	1	2.5	1.2	0.2

Inter-phase barrier

Use

Safe isolation between the terminals, essential for use at 690 VAC or in a polluted or dusty atmosphere.

For 3/4 poles SIRCO and SIRCO AC

Rating (A) / Frame size	SIRCO AC	No. of poles	Reference
125 ... 160 / B3		3 P	2998 0033
125 ... 160 / B3		4 P	2998 0034
200 ... 250 / B4	200 ... 315 / B4	3 P	2998 0023
200 ... 250 / B4	200 ... 315 / B4	4 P	2998 0024
315 ... 630 / B5	315 ... CD 360 / B5	3 P	2998 0013
315 ... 630 / B5	315 ... CD 360 / B5	4 P	2998 0014
800 ... 5000 / B6 ... B9	630 ... 4000 / B6 ... B9	3 P	included
800 ... 5000 / B6 ... B9	630 ... 4000 / B6 ... B9	4 P	included



access_036_a_1_cat

SIRCO

Load break switches for power distribution
from 125 to 5000 A

Accessories (continued)

Terminal shrouds

Use

Top or bottom protection against direct contact with terminals or connection parts.

Advantage

Perforations allow remote thermographic inspection without the need to remove the shrouds. The terminal shrouds also provide phase separation for SIRCO and SIRCO AC from 125 to 630 A.



access_077_a_1_cat

For 3/4 poles SIRCO and SIRCO AC

Rating (A) / Frame size	SIRCO AC	No. of poles	Position	Reference
125 ... 160 / B3		3 P	top or bottom	2694 3014 ⁽¹⁾
125 ... 160 / B3		4 P	top or bottom	2694 4014 ⁽²⁾
200 ... 250 / B4	200 ... 315 / B4	3 P	top or bottom	2694 3021 ⁽¹⁾
200 ... 250 / B4	200 ... 315 / B4	4 P	top or bottom	2694 4021 ⁽²⁾
315 ... 630 / B5	400 ... CD 630 / B5	3 P	top or bottom	2694 3051 ⁽¹⁾
315 ... 630 / B5	400 ... CD 630 / B5	4 P	top or bottom	2694 4051 ⁽²⁾

(1) Reference includes 3 parts for top or bottom protection.
(2) Reference includes 4 parts for top or bottom protection.

For 6/8-pole SIRCO

Rating (A) / Frame size	No. of poles	Position	Reference
125 ... 160 / B3 _{DS}	6 P	Top or bottom	2694 3014 ⁽¹⁾⁽³⁾
125 ... 160 / B3 _{DS}	8 P	Top or bottom	2694 4014 ⁽²⁾⁽³⁾
250 / B4 _{DS}	6 P	Top or bottom	2694 3021 ⁽¹⁾⁽³⁾
250 / B4 _{DS}	8 P	Top or bottom	2694 4021 ⁽²⁾⁽³⁾
400 ... 630 / B5 _{DS}	6 P	Top or bottom	2694 3051 ⁽¹⁾⁽³⁾
400 ... 630 / B5 _{DS}	8 P	Top or bottom	2694 4051 ⁽²⁾⁽³⁾

(1) Reference includes 3 parts for top or bottom protection on the front or rear of the device.
(2) Reference includes 4 parts for top or bottom protection on the front or rear of the device.
(3) Select 2 sets for front or rear.

Distribution block

Use

Easy connection of multiple cables, bottom of the SIRCO.

For 3/4-pole SIRCO

Rating (A) / Frame size	No. of poles	No. of feeders per section (mm ²)	I _{cc} (kA rms) ⁽¹⁾	Reference
160 / B3	3 P	1x95 + 8x25	10	5411 3016
160 / B3	4 P	1x95 + 8x25	10	5411 4016
250 / B4	3 P	1x150 + 8x50	15	5411 3025
250 / B4	4 P	1x150 + 8x50	15	5411 4025
400 / B5	3 P	1x240 + 8x95	21	5411 3040
400 / B5	4 P	1x240 + 8x95	21	5411 4040
630 / B5	3 P	1x300 + 8x150	21	5411 3063
630 / B5	4 P	1x300 + 8x150	21	5411 4063

Dimensions

Rating (A) / Frame size	No. of poles	A	B	T	H	K	P	R	T	Y
160 / B3	3 P	154	286	73	46.5	261.5	36	20	4	54
160 / B3	4 P	190	286	73	46.5	261.5	36	20	4	54
250 / B4	3 P	210	307	83	57.5	279	50	25	4	56
250 / B4	4 P	260	307	83	57.5	279	50	25	4	56
400 / B5	3 P	281	375	116	82.5	340	65	32	5	82
400 / B5	4 P	346	375	116	82.5	340	65	32	5	82
630 / B5	3 P	271	438	117	90.5	410.5	65	40	6	83
630 / B5	4 P	346	438	117	90.5	410.5	65	40	6	83

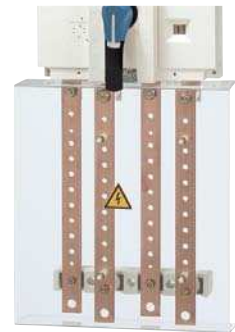

repair_020_c_2_cat

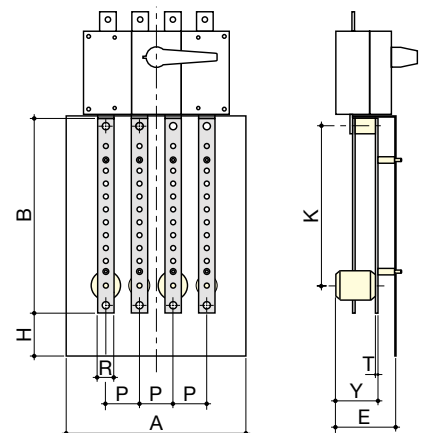

repair_003_c_1_x_cat

Terminal screens

Use

Top or bottom protection from direct contact with terminals or connection parts.

For 3/4 poles SIRCO and SIRCO AC

Rating (A) / Frame size		No. of poles	Position	Reference
SIRCO	SIRCO AC			
125 ... 160 / B3		3 P	top or bottom	2698 3012
125 ... 160 / B3		4 P	top or bottom	2698 4012
200 ... 250 / B4	200 ... 315 / B4	3 P	top or bottom	2698 3020
200 ... 250 / B4	200 ... 315 / B4	4 P	top or bottom	2698 4020
315 ... 630 / B5	400 ... CD 630 / B5	3 P	top or bottom	2698 3050
315 ... 630 / B5	400 ... CD 630 / B5	4 P	top or bottom	2698 4050
800 ... CD 1250 / B6	630 ... CD 1250 / B6	3 P	top or bottom	2698 3080
800 ... CD 1250 / B6	630 ... CD 1250 / B6	4 P	top or bottom	2698 4080
1250 ... 1800 / B7	1250 ... 1600 / B7	3 P	top or bottom	2698 3120
1250 ... 1800 / B7	1250 ... 1600 / B7	4 P	top or bottom	2698 4120
2000 ... 3200 / B8	2000 / B8	3 P	top or bottom	2698 3200
2000 ... 3200 / B8	2000 / B8	4 P	top or bottom	2698 4200
4000 ... 5000 / B9	4000 / B9	3/4 P	top or bottom	1509 4200



access_079_a_1_cat

For 6/8-pole SIRCO

Rating (A) / Frame size	No. of poles	Position	Reference
125 ... 160 / B3 _{DS}	6 P	Top or bottom	1509 3012
125 ... 160 / B3 _{DS}	8 P	Top or bottom	1509 4012
250 / B4 _{DS}	6 P	Top or bottom	1509 3025
250 / B4 _{DS}	8 P	Top or bottom	1509 4025
400 ... 630 / B5 _{DS}	6 P	Top or bottom	1509 3063
400 ... 630 / B5 _{DS}	8 P	Top or bottom	1509 4063
800 ... 1250 / B6 _{DS} -B7 _{DS}	6 P	Top or bottom	1509 3080
800 ... 1250 / B6 _{DS} -B7 _{DS}	8 P	Top or bottom	1509 4080
1600 / B7 _{DS}	6 P	Top or bottom	1509 3160
1600 / B7 _{DS}	8 P	Top or bottom	1509 4160

Cage terminals

Use

They enable a direct terminal-free connection to rigid copper and aluminium conductors with integration under the IP2X protective cover.

Material: tin-plated aluminium

Dimensions

Rating (A) / Frame size	A	A1	C	T	R	T	ØX	X1	Z
125 ... 160 / B3	47.5	22.5	25	12	20	3.5	8.5	M12	10
200 ... 250 / B4	62	31.5	31.5	16.5	25	2.5	10.5	M16	14
315 ... 400 / B5	71.5	32	38	9	32	5	10.5	M20	15
500 ... 630 / B5	76.5	37	38	9	40	5	12.5	M20	15

References

Rating (A) / Frame size	Tightening capacity (mm ²)	No. of poles	Tightening torque (Nm)	Flexible bar width (mm)	Reference
125 ... 160 / B3	16 ... 95	3 P	14	13	5400 3016
125 ... 160 / B3	16 ... 95	4 P	14	13	5400 4016
200 ... 250 / B4	16 ... 185	3 P	25	18	5400 3025
200 ... 250 / B4	16 ... 185	4 P	25	18	5400 4025
315 ... 400 / B5	50 ... 240	3 P	45	20	5400 3040
315 ... 400 / B5	50 ... 240	4 P	45	20	5400 4040
500 ... 630 / B5	70 ... 300	3 P	45	24	5400 3063
500 ... 630 / B5	70 ... 300	4 P	45	24	5400 4063

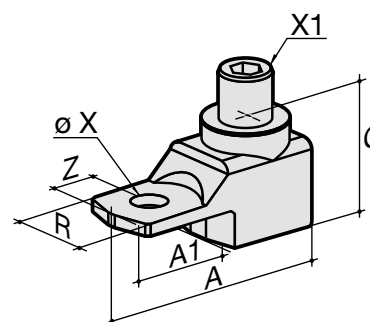

born_019_a_1_x_cat

Accessories (continued)

Copper bar connection kits

Use

To allow connection between the two power terminals of the same pole for 2000 to 3200 A ratings (Fig. 1 and Fig 2).

For 3200 A rating, the connection pieces (part A) are delivered bridged as standard.

Bolt sets must be ordered separately.

Further details for these specific accessories are available in the user guide downloadable from www.socomec.com.

Top or bottom flat connection - Fig. 1

Rating (A) / Frame size	Part	Quantity to order per pole ⁽¹⁾	Reference
2000 ... 2500 / B8	Connection - part A	1	2619 1200
2000 ... 2500 / B8	Bolt set - part B	1	2699 1200
3200 / B8	Connection - part A		included
3200 / B8	Bolt set - part B	1	2699 1200
4000 ... 5000 / B9	Standard connection		

(1) Example for 3-pole device equipped top only: order 3 times the indicated quantity.

Fig. 1

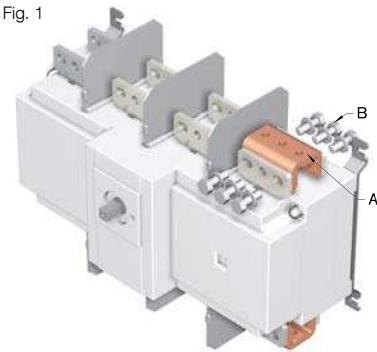

access_220_c_1_x_cat

Fig. 1

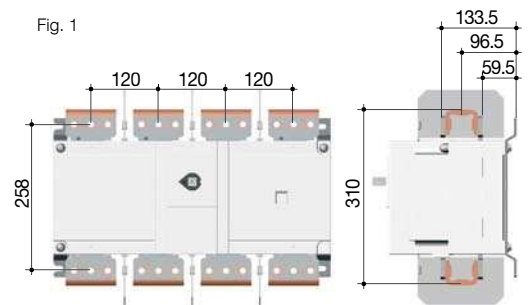

access_224_a_1_cat

Top or bottom edgewise connection - Fig. 2

Rating (A) / Frame size	Part	Quantity to order per pole ⁽¹⁾	Reference
2000 ... 2500 / B8	Connection - part A	1	2619 1200
2000 ... 2500 / B8	T piece - part C	1	2629 1200⁽²⁾
2000 ... 2500 / B8	Bracket - part D	1	2639 1200⁽²⁾
3200 / B8	Connection - part A		included
3200 / B8	T piece - part C	1	2629 1200
3200 / B8	Bracket - part D	1	2639 1200
4000 ... 5000 / B9	Standard connection		

(1) Example for 3-pole device equipped top only: order 3 times the indicated quantity.
(2) Bolt set is provided with the accessories.

Fig. 2

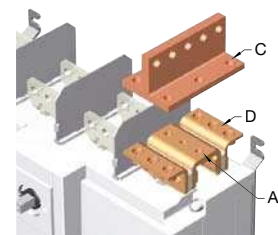

access_222_b_1_x_cat

Fig. 2

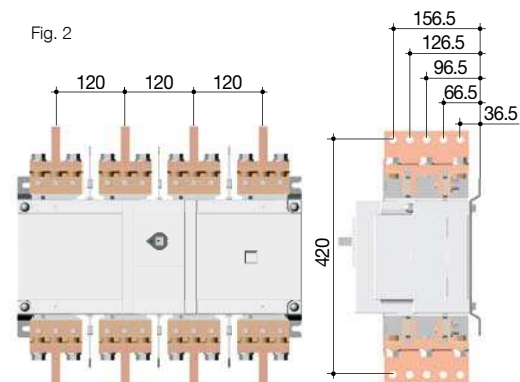

access_225_a_1_cat

Key handle interlocking system

Use

Locking in position 0 of the front or side operation handle:

- using a padlock (not supplied) and standard padlocking function of the handle. From 125 to 1800 A, padlocking the external front operation handle provides door interlocking,

- using a lock (not supplied): see diagrams opposite,
- using an undervoltage coil: the SIRCO can only be closed if the coil is energised.

For 6 / 8-pole, please consult us.

For SIRCO

Locking using RONIS EL11AP lock (not supplied)

Rating (A) / Frame size	No. of poles	Operation	Figure	Reference
125 ... 630 / B3 ... B5	3/4 P	Front direct	1	2699 6008 ⁽¹⁾
125 ... 1800 / B3 ... B7	3/4 P	External front	3	1499 7701
800 ... 3200 / B6 ... B8	3/4 P	Front direct	2	2699 6027
1250 ... 5000 / B7 ... B9	3/4 P	External front	4	2799 7002

(1) Front operation handle included.

For SIRCO AC

Locking using RONIS EL11AP lock (not supplied)

Rating (A) / Frame size	No. of poles	Operation	Figure	Reference
200 ... CD 630 / B4 ... B5	3/4 P	Front direct	1	2699 6011 ⁽¹⁾
630 ... 1600 / B6 ... B7	3/4 P	Front direct	2	2699 6028

(1) The locking system is directly mounted on the device.

For SIRCO

Locking using 230 VAC undervoltage coil

(For other voltages, please contact us)

Rating (A) / Frame size	No. of poles	Operation	Reference
125 ... 630 / B3 ... B5	3/4 P	External front	2699 9063 ⁽¹⁾
800 ... 3200 / B6 ... B8	3/4 P	Front direct	2699 9315 ⁽¹⁾

(1) The locking system is directly mounted on the device.

Locking using CASTELL lock (not supplied)

Rating (A) / Frame size	No. of poles	Handle type	Lock type	Operation	Figure	Reference
125 ... 160 / B3	6/8 P	S2	K	External front	2	4109 8507
125 ... 1 800 / B3 ... B8	3/4 P	S2, S4	FS	External front	3	1499 7703
125 ... 1 800 / B3 ... B8	3/4 P	S2, S4	K	External front	3	1499 7702
250 ... 630 / B4 ... B5	6/8 P	S4	K	External front	2	2999 8707
800 ... 1 600 / B6 ... B7	6/8 P	S5	K	External front	2	2799 7003
1 250 ... 4 000 / B7 ... B9	3/4 P	S5, S0	K	External front	2	2799 7003

Fig. 1

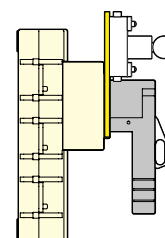

Fig. 3

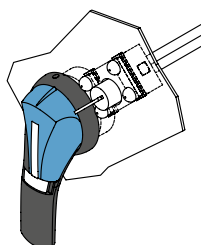

Fig. 2

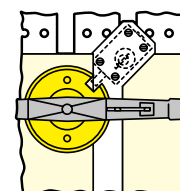
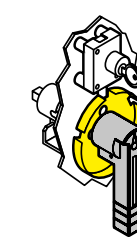

Fig. 4



Other specific accessories



- Mechanical coupling device for making switches with "n" poles of the same or different ratings
- Mechanical interlocking device

SIRCO characteristics according to IEC 60947-3

125 to 800 A

Thermal current I_{th} at 40°C	125 A	160 A	200 A	250 A	315 A	400 A	500 A	630 A	800 A
Frame size	B3	B3	B4	B4	B5	B5	B5	B5	B6
Rated insulation voltage U_i (V)	800	800	800	800	1000	1000	1000	1000	1000
Rated impulse withstand voltage U_{imp} (kV)	8	8	8	8	12	12	12	12	12

Rated operational currents I_e (A)

Rated voltage	Utilisation category	A / B ⁽¹⁾	A / B ⁽¹⁾	A / B ⁽¹⁾	A / B ⁽¹⁾	A / B ⁽¹⁾	A / B ⁽¹⁾	A / B ⁽¹⁾	A / B ⁽¹⁾	A / B ⁽¹⁾
415 VAC	AC-20 A / AC-20 B	125 / 125	160 / 160	200 / 200	250 / 250	315 / 315	400 / 400	500 / 500	630 / 630	800 / 800
415 VAC	AC-21 A / AC-21 B	125 / 125	160 / 160	200 / 200	250 / 250	315 / 315	400 / 400	500 / 500	630 / 630	800 / 800
415 VAC	AC-22 A / AC-22 B	125 / 125	160 / 160	200 / 200	250 / 250	315 / 315	400 / 400	500 / 500	630 / 630	800 / 800
415 VAC	AC-23 A / AC-23 B	125 / 125	160 / 160	200 / 200	250 / 250	315 / 315	400 / 400	500 / 500	500 / 500	800 / 800
220 VDC	DC-20 A / DC-20 B	125 / 125	160 / 160	200 / 200	250 / 250	315 / 315	400 / 400	500 / 500	630 / 630	800 / 800
220 VDC	DC-21 A / DC-21 B	125 / 125	160 / 160	160 / 200	250 / 250	315 / 315	400 / 400	500 / 500	630 / 630	800 / 800
220 VDC	DC-22 A / DC-22 B	125 / 125	160 / 160	160 / 200	250 / 250	315 / 315	400 / 400	400 / 500	500 / 500	800 / 800
220 VDC	DC-23 A / DC-23 B	125 / 125	125 / 125	160 / 160	200 / 200	315 / 315	400 / 400	400 / 400	500 / 500	800 / 800
440 VDC	DC-20 A / DC-20 B	125 / 125	160 / 160	200 / 200	250 / 250	315 / 315	400 / 400	500 / 500	630 / 630	800 / 800
440 VDC	DC-21 A / DC-21 B	125 ⁽³⁾ / 125 ⁽³⁾	160 ⁽³⁾ / 160 ⁽³⁾	160 ⁽³⁾ / 200 ⁽³⁾	200 ⁽³⁾ / 200 ⁽³⁾	315 ⁽³⁾ / 315 ⁽³⁾	400 ⁽³⁾ / 400 ⁽³⁾	400 ⁽³⁾ / 400 ⁽³⁾	500 ⁽³⁾ / 500 ⁽³⁾	800 ⁽⁴⁾ / 800 ⁽⁴⁾
440 VDC	DC-22 A / DC-22 B	125 ⁽³⁾ / 125 ⁽³⁾	125 ⁽³⁾ / 125 ⁽³⁾	160 ⁽³⁾ / 160 ⁽³⁾	200 ⁽³⁾ / 200 ⁽³⁾	315 ⁽³⁾ / 315 ⁽³⁾	400 ⁽³⁾ / 400 ⁽³⁾	400 ⁽³⁾ / 400 ⁽³⁾	500 ⁽³⁾ / 500 ⁽³⁾	800 ⁽⁴⁾ / 800 ⁽⁴⁾
440 VDC	DC-23 A / DC-23 B	125 ⁽⁴⁾ / 125 ⁽⁴⁾	125 ⁽⁴⁾ / 125 ⁽⁴⁾	160 ⁽⁴⁾ / 160 ⁽⁴⁾	200 ⁽⁴⁾ / 200 ⁽⁴⁾	315 ⁽⁴⁾ / 315 ⁽⁴⁾	400 ⁽⁴⁾ / 400 ⁽⁴⁾	400 ⁽⁴⁾ / 400 ⁽⁴⁾	500 / 500	800 ⁽⁴⁾ / 800 ⁽⁴⁾
500 VDC	DC-20 A / DC-20 B	125 / 125	160 / 160	200 / 200	250 / 250	315 / 315	400 / 400	500 / 500	630 / 630	800 / 800
500 VDC	DC-21 A / DC-21 B	125 ⁽³⁾ / 125 ⁽³⁾	125 ⁽³⁾ / 125 ⁽³⁾	160 ⁽³⁾ / 200 ⁽³⁾	200 ⁽³⁾ / 200 ⁽³⁾	315 ⁽³⁾ / 315 ⁽³⁾	400 ⁽³⁾ / 400 ⁽³⁾	400 ⁽³⁾ / 400 ⁽³⁾	500 ⁽³⁾ / 500 ⁽³⁾	800 ⁽⁴⁾ / 800 ⁽⁴⁾
500 VDC	DC-22 A / DC-22 B	125 ⁽⁴⁾ / 125 ⁽⁴⁾	125 ⁽⁴⁾ / 125 ⁽⁴⁾	160 ⁽⁴⁾ / 160 ⁽⁴⁾	200 ⁽⁴⁾ / 200 ⁽⁴⁾	315 ⁽⁴⁾ / 315 ⁽⁴⁾	315 ⁽⁴⁾ / 400 ⁽⁴⁾	315 ⁽⁴⁾ / 400 ⁽⁴⁾	500 ⁽⁴⁾ / 500 ⁽⁴⁾	800 ⁽⁴⁾ / 800 ⁽⁴⁾
500 VDC	DC-23 A / DC-23 B	125 ⁽⁴⁾ / 125 ⁽⁴⁾	125 ⁽⁴⁾ / 125 ⁽⁴⁾	160 ⁽⁴⁾ / 160 ⁽⁴⁾	200 ⁽⁴⁾ / 200 ⁽⁴⁾	315 ⁽⁴⁾ / 315 ⁽⁴⁾	315 ⁽⁴⁾ / 400 ⁽⁴⁾	315 ⁽⁴⁾ / 400 ⁽⁴⁾	500 ⁽⁴⁾ / 500 ⁽⁴⁾	800 ⁽⁴⁾ / 800 ⁽⁴⁾

Operational power in AC-23 (kW)⁽¹⁾⁽⁵⁾

At 415 VAC without AC pre-break ⁽¹⁾	63 / 63	80 / 80	100 / 100	132 / 132	160 / 160	220 / 220	280 / 280	280 / 280	450 / 450
--	---------	---------	-----------	-----------	-----------	-----------	-----------	-----------	-----------

Reactive power (kvar)

At 400 VAC (kvar) ⁽⁵⁾	55	75	90	115	145	185	230	290	365
----------------------------------	----	----	----	-----	-----	-----	-----	-----	-----

gG DIN fuse protected short-circuit withstand (kA rms prospective)⁽⁶⁾

Prospective short-circuit current (kA rms)	100	100	80	50	100	100	100	70	50
Associated fuse rating (A)	125	160	200	250	315	400	500	630	800

Circuit breaker protected short-circuit withstand with any circuit breaker that ensures tripping in less than 0.3s

Rated short-time withstand current 0.3s. I_{sw} (kA rms)	15	15	17	17	25	25	25	25	50
--	----	----	----	----	----	----	----	----	----

Short-circuit operation (switch only)

Rated short-time withstand current I_{sw} 1s (kA rms)	7	7	9	9	13	13	13	13	26
Rated peak withstand current in I_{cc} (kA peak) ⁽⁶⁾⁽⁷⁾	20	20	30	30	45	45	45	45	55

Connection

Minimum Cu cable cross-section (mm ²)	35	50	70	95	150	185	240	2 x 150	2 x 185
Minimum Cu busbar cross-section (mm ²)								2 x 30 x 5	2 x 40 x 5
Maximum Cu cable cross-section (mm ²)	50	95	95	150	240	240	240	2 x 300	2 x 300
Maximum Cu busbar width (mm)	25	25	32	32	40	40	40	50	63
Tightening torque min/max (Nm)	9 / -	9 / -	20 / -	20 / -	20 / -	20 / -	20 / -	40 / 45	40 / 45

Mechanical characteristics

Durability (number of operating cycles)	10000	10000	10000	10000	10000	10000	10000	10000	3000
Operating effort (Nm)	6.5	6.5	10	10	14.5	14.5	14.5	14.5	37
Weight of a 3-pole device (kg)	1	1.5	2	2	3.5	3.5	3.5	3.5	8
Weight of a 4-pole device (kg)	1.5	1.5	2	2	4	4	4.5	4.5	10

(1) Category with index A = frequent operation - Category with index B = infrequent operation.

(2) With terminal shrouds or phase barrier.

(3) 3-pole device with 2 poles in series for the '+' and 1 pole for the '-'.
(4) 4-pole device with 2 poles in series per polarity.

(5) The power value is given for information only, the current values vary from one manufacturer to another.

(6) For a rated operational voltage $U_n = 415$ VAC.

(7) Coordination tables with circuit breaker: please consult us.

SIRCO characteristics according to IEC 60947-3

1000 to 5000 A

Thermal current I_{th} at 40°C	1000 A	CD 1250 A	1250 A	1600 A	1800 A	2000 A	2500 A	3200 A	4000 A	5000 A
Frame size	B6	B6	B7	B7	B7	B8	B8	B8	B9	B9
Rated insulation voltage U_i (V)	1000	1000	1000	1000	1000	1000	1000	1000	1000	1000
Rated impulse withstand voltage U_{imp} (kV)	12	12	12	12	12	12	12	12	12	12

Rated operational currents I_e (A)

Rated voltage	Utilisation category	A/B ⁽¹⁾	A/B ⁽¹⁾	A/B ⁽¹⁾	A/B ⁽¹⁾	A/B ⁽¹⁾	A/B ⁽¹⁾	A/B ⁽¹⁾	A/B ⁽¹⁾	A/B ⁽¹⁾	A/B ⁽¹⁾
415 VAC	AC-20 A / AC-20 B	1000 / 1000	1250 / 1250	1250 / 1250	1600 / 1600	1800 / 1800	2000 / 2000	2500 / 2500	3200 / 3200	4000 / 4000	5000 / 5000
415 VAC	AC-21 A / AC-21 B	1000 / 1000	1250 / 1250	1250 / 1250	1600 / 1600	1800 / 1800	2000 / 2000	2500 / 2500	3200 / 3200	4000 / 4000	5000 / 5000
415 VAC	AC-22 A / AC-22 B	1000 / 1000	1250 / 1250	1250 / 1250	1600 / 1600	1800 / 1800	2000 / 2000	2500 / 2500	2500 / 3200	2500 / 3200	2500 / 3200
415 VAC	AC-23 A / AC-23 B	1000 / 1000	1250 / 1250	1250 / 1250	1250 / 1250	1250 / 1250	1600 / 1600	1600 / 1600	1600 / 1600	1800 / 2000	1800 / 2000
220 VDC	DC-20 A / DC-20 B	1000 / 1000	1250 / 1250	1250 / 1250	1600 / 1600	1800 / 1800	2000 / 2000	2000 / 2500	3200 / 3200	4000 / 4000	5000 / 5000
220 VDC	DC-21 A / DC-21 B	1000 / 1000	1250 / 1250	1250 / 1250	1250 / 1600	1250 / 1600	2000 / 2000	2000 / 2500	2000 / 2500	2500 / 3200	2500 / 3200
220 VDC	DC-22 A / DC-22 B	1000 / 1000	1250 / 1250	1250 / 1250	1250 / 1250	1250 / 1250	1250 / 1600	1250 / 1600	1250 / 1600	1800 / 2000	1800 / 2000
220 VDC	DC-23 A / DC-23 B	1000 / 1000	1250 / 1250	1250 / 1250	1250 / 1250	1250 / 1250	1250 / 1250	1250 / 1250	1250 / 1250	1250 / 1600	1250 / 1600
440 VDC	DC-20 A / DC-20 B	1000 / 1000	1250 / 1250	1250 / 1250	1600 / 1600	1800 / 1800	2000 / 2000	2500 / 2500	3200 / 3200	4000 / 4000	5000 / 5000
440 VDC	DC-21 A / DC-21 B	1000 ⁽⁴⁾ / 1000 ⁽⁴⁾	1250 ⁽⁴⁾ / 1250 ⁽⁴⁾	1250 ⁽⁴⁾ / 1250 ⁽⁴⁾	1250 ⁽⁴⁾ / 1600 ⁽⁴⁾	1250 ⁽⁴⁾ / 1600 ⁽⁴⁾	2000 ⁽⁴⁾ / 2000 ⁽⁴⁾	2000 ⁽⁴⁾ / 2500 ⁽⁴⁾	2500 ⁽⁴⁾ / 3200 ⁽⁴⁾	3200 ⁽⁴⁾ / 4000 ⁽⁴⁾	3200 ⁽⁴⁾ / 5000 ⁽⁴⁾
440 VDC	DC-22 A / DC-22 B	1000 ⁽⁴⁾ / 1000 ⁽⁴⁾	1250 ⁽⁴⁾ / 1250 ⁽⁴⁾	1250 ⁽⁴⁾ / 1250 ⁽⁴⁾	1250 ⁽⁴⁾ / 1250 ⁽⁴⁾	1250 ⁽⁴⁾ / 1250 ⁽⁴⁾	1250 ⁽⁴⁾ / 1250 ⁽⁴⁾	1250 ⁽⁴⁾ / 1250 ⁽⁴⁾	1250 ⁽⁴⁾ / 1250 ⁽⁴⁾	1600 ⁽⁴⁾ / 1800 ⁽⁴⁾	1600 ⁽⁴⁾ / 1800 ⁽⁴⁾
440 VDC	DC-23 A / DC-23 B	1000 ⁽⁴⁾ / 1000 ⁽⁴⁾	1250 ⁽⁴⁾ / 1250 ⁽⁴⁾	1250 ⁽⁴⁾ / 1250 ⁽⁴⁾	1250 ⁽⁴⁾ / 1250 ⁽⁴⁾	1250 ⁽⁴⁾ / 1250 ⁽⁴⁾	1250 ⁽⁴⁾ / 1250 ⁽⁴⁾	1250 ⁽⁴⁾ / 1250 ⁽⁴⁾	1250 ⁽⁴⁾ / 1250 ⁽⁴⁾	1250 ⁽⁴⁾ / 1250 ⁽⁴⁾	1250 ⁽⁴⁾ / 1250 ⁽⁴⁾
500 VDC	DC-20 A / DC-20 B	1000 / 1000	1250 / 1250	1250 / 1250	1600 / 1600	1800 / 1800	2000 / 2000	2500 / 2500	3250 / 3250	4000 / 4000	5000 / 5000
500 VDC	DC-21 A / DC-21 B	1000 ⁽⁴⁾ / 1000 ⁽⁴⁾	1250 ⁽⁴⁾ / 1250 ⁽⁴⁾	1250 ⁽⁴⁾ / 1250 ⁽⁴⁾	1250 ⁽⁴⁾ / 1600 ⁽⁴⁾	1250 ⁽⁴⁾ / 1600 ⁽⁴⁾	1250 ⁽⁴⁾ / 1250 ⁽⁴⁾	1250 ⁽⁴⁾ / 1250 ⁽⁴⁾	1250 ⁽⁴⁾ / 1250 ⁽⁴⁾	1600 ⁽⁴⁾ / 1800 ⁽⁴⁾	1600 ⁽⁴⁾ / 1800 ⁽⁴⁾
500 VDC	DC-22 A / DC-22 B	1000 ⁽⁴⁾ / 1000 ⁽⁴⁾	1250 ⁽⁴⁾ / 1250 ⁽⁴⁾	1250 ⁽⁴⁾ / 1250 ⁽⁴⁾	1250 ⁽⁴⁾ / 1250 ⁽⁴⁾	1250 ⁽⁴⁾ / 1250 ⁽⁴⁾	1250 ⁽⁴⁾ / 1250 ⁽⁴⁾	1250 ⁽⁴⁾ / 1250 ⁽⁴⁾	1250 ⁽⁴⁾ / 1250 ⁽⁴⁾	1250 ⁽⁴⁾ / 1600 ⁽⁴⁾	1250 ⁽⁴⁾ / 1600 ⁽⁴⁾
500 VDC	DC-23 A / DC-23 B	1000 ⁽⁴⁾ / 1000 ⁽⁴⁾	1250 ⁽⁴⁾ / 1250 ⁽⁴⁾	1250 ⁽⁴⁾ / 1250 ⁽⁴⁾	1250 ⁽⁴⁾ / 1250 ⁽⁴⁾	1250 ⁽⁴⁾ / 1250 ⁽⁴⁾	1000 ⁽⁴⁾ / 1000 ⁽⁴⁾	1000 ⁽⁴⁾ / 1000 ⁽⁴⁾	1000 ⁽⁴⁾ / 1000 ⁽⁴⁾	1000 ⁽⁴⁾ / 1000 ⁽⁴⁾	1000 ⁽⁴⁾ / 1000 ⁽⁴⁾

Operational power in AC-23 (kW)⁽¹⁾⁽⁶⁾

At 415 VAC without AC pre-break ⁽¹⁾	560 / 560	710 / 710	710 / 710	710 / 710	710 / 710	710 / 710	710 / 710	710 / 710	710 / 710	710 / 710	710 / 710
--	-----------	-----------	-----------	-----------	-----------	-----------	-----------	-----------	-----------	-----------	-----------

Reactive power (kvar)

At 400 VAC (kvar) ⁽⁵⁾	460										
----------------------------------	-----	--	--	--	--	--	--	--	--	--	--

gG DIN fuse protected short-circuit withstand (kA rms prospective)⁽⁶⁾

Prospective short-circuit current (kA rms)	100	100	100	100	100	100	100				
Associated fuse rating (A)	1000	1250	1250	2 x 800	2 x 800	2 x 1000	2 x 1250				

Circuit breaker protected short-circuit withstand with any circuit breaker that ensures tripping in less than 0.3s

Rated short-time withstand current 0.3s. I_{cw} (kA rms)	65	65	100	100	100	100	100	100			
--	----	----	-----	-----	-----	-----	-----	-----	--	--	--

Short-circuit operation (switch only)

Rated short-time withstand current I_{cw} 1s (kA rms)	35	35	50	50	50	50	50	50	75	75	
Rated peak withstand current I_{cc} (kA peak) ⁽⁶⁾⁽⁷⁾	80	80	110	110	110	110	110	110	120	165	165

Connection

Minimum Cu cable cross-section (mm ²)	2 x 240										
Minimum Cu busbar cross-section (mm ²)	2 x 50 x 5	2 x 60 x 5	2 x 60 x 5	2 x 80 x 5	3 x 100 x 5	3 x 100 x 5	4 x 100 x 5	4 x 100 x 5	2 x 200 x 10	2 x 200 x 10	
Maximum Cu cable cross-section (mm ²)	4 x 185	4 x 185	4 x 185	6 x 185	6 x 185						
Maximum Cu busbar width (mm)	63	63	100	100	100	100	100	100			
Tightening torque min/max (Nm)	40/45	40/45	40/45	40/45	40/45	40/45	40/45	40/-	40/-	40/-	40/-

Mechanical characteristics

Durability (number of operating cycles)	3000	3000	4000	4000	4000	3000	3000	3000	2000	2000	
Operating effort (Nm)	37	37	56	56	56	75	75	75	105	105	
Weight of a 3-pole device (kg)	8	8	12	12	12	22	22	22	45	45	
Weight of a 4-pole device (kg)	10	10	15	15	15	25	25	25	50	50	

(1) Category with index A = frequent operation - Category with index B = infrequent operation.

(2) With terminal shrouds or phase barrier.

(3) 3-pole device with 2 poles in series for the '+' and 1 pole for the '-'.

(4) 4-pole device with 2 poles in series per polarity.

(5) The power value is given for information only, the current values vary from one manufacturer to another.

(6) For a rated operational voltage $U_o = 415$ VAC.

(7) Coordination tables with circuit breaker: please consult us.

SIRCO AC characteristics according to IEC 60947-3

200 to 630 A

Thermal current I_{th} at 40°C	200 A	250 A	315 A	400 A	500 A	CD 630 A	630 A
Rated insulation voltage U_i (V)	1000	1000	1000	1000	1000	1000	1000
Rated impulse withstand voltage U_{imp} (kV)	12	12	12	12	12	12	12
Rated operational currents I_e (A)							
Rated voltage	Utilisation category	A/B ⁽¹⁾	A/B ⁽¹⁾	A/B ⁽¹⁾	A/B ⁽¹⁾	A/B ⁽¹⁾	A/B ⁽¹⁾
500 VAC	AC-20 A / AC-20 B	200/200	250/250	315/315	400/400	500/500	630/630
500 VAC	AC-21 A / AC-21 B	200/200	250/250	315/315	400/400	500/500	630/630
500 VAC	AC-22 A / AC-22 B	200/200	250/250	315/315	400/400	500/500	630/630
500 VAC	AC-23 A / AC-23 B	200/200	250/250	315/315	400/400	500/500	630/630
690 VAC	AC-20 A / AC-20 B	200/200	250/250	315/315	400/400	500/500	630/630
690 VAC	AC-21 A / AC-21 B	200/200	250/250	315/315	400 ⁽²⁾ /400 ⁽²⁾	500 ⁽²⁾ /500 ⁽²⁾	630 ⁽²⁾ /630 ⁽²⁾
690 VAC	AC-22 A / AC-22 B	200/200	250/250	315/315	400 ⁽²⁾ /400 ⁽²⁾	500 ⁽²⁾ /500 ⁽²⁾	630 ⁽²⁾ /630 ⁽²⁾
690 VAC	AC-23 A / AC-23 B	200/200	250/250	315/315	400 ⁽²⁾ /400 ⁽²⁾	500 ⁽²⁾ /500 ⁽²⁾	630 ⁽²⁾ /630 ⁽²⁾
Operational power in AC-23 A (kW) ⁽³⁾							
At 690 VAC without pre-break AC	160	220	250	400	500	500	630
Reactive power (kvar)							
At 690 VAC (kvar)	160	190	250	325	400	400	450
Fuse protected short-circuit withstand (kA rms prospective) at 690 VAC ⁽⁴⁾							
Prospective short-circuit current (kA rms)	50	50	50	50	50	50	50
Associated fuse rating (A)	200	250	315	400	500	630	630
Circuit breaker protected short-circuit withstand with any circuit breaker that ensures tripping in less than 0.3s at 690 VAC							
Rated short-time withstand current 0.3s. I_{cw} (kA rms)	15	15	15	15	15	15	28
Short-circuit capacity (without protection)							
Rated short-time withstand current 1s. I_{cw} (kA rms)	8	8	8	11	11	11	20
Rated short-circuit making capacity without fuses I_{cm} (kA peak)	22	22	22	22	22	22	40
Connection							
Maximum Cu cable cross-section (mm ²)	70	70	70	185	240	2 x 150	2 x 185
Minimum Cu busbar cross-section (mm ²)						2 x 30 x 5	2 x 40 x 5
Maximum Cu cable cross-section (mm ²)	95	95	95	240	240	2 x 300	2 x 300
Maximum Cu busbar width (mm)	32	32	32	40	40	63	63
Tightening torque min/max (Nm)	20/-	20/-	20/-	20/-	20/-	20/-	40/45
Mechanical characteristics							
Durability (number of operating cycles)	10000	10000	10000	5000	5000	5000	4000
Operating effort (Nm)	10	10	10	14.5	14.5	14.5	48
Weight of a 3 pole device (kg)	2	2	2	3.5	3.5	3.5	8
Weight of a 4 pole device (kg)	2	2	2	4	4	4	10

(1) Category with index A = frequent operation - Category with index B = infrequent operation.

(2) With terminal shrouds or phase barrier.

(3) The power value is given for information only, the current values vary from one manufacturer to another.

(6) For a rated operational voltage $U_e = 690$ VAC.

SIRCO AC characteristics according to IEC 60947-3

800 to 4000 A

Thermal current I_{th} at 40°C	800 A	1000A	CD 1250 A	1250 A	1600 A	2000 A	4000 A
Rated insulation voltage U_i (V)	1000	1000	1000	1000	1000	1000	1000
Rated impulse withstand voltage U_{imp} (kV)	12	12	12	12	12	12	12

 Rated operational currents I_e (A)

Rated voltage	Utilisation category	A/B ⁽¹⁾	A/B ⁽¹⁾	A/B ⁽¹⁾	A/B ⁽¹⁾	A/B ⁽¹⁾	A/B ⁽¹⁾	A/B ⁽¹⁾
500 VAC	AC-20 A / AC-20 B	800/800	1000/1000	1250/1250	1250/1250	1600/1600	2000/2000	4000/4000
500 VAC	AC-21 A / AC-21 B	800/800	1000/1000	1250/1250	1250/1250	1600/1600	2000/2000	-/3200
500 VAC	AC-22 A / AC-22 B	800/800	1000/1000	1250/1250	1250/1250	1600/1600	2000/2000	-
500 VAC	AC-23 A / AC-23 B	800/800	1000/1000	1250/1250	1250/1250	1250/1250	1600/1600	-
690 VAC	AC-20 A / AC-20 B	800/800	1000/1000	1250/1250	1250/1250	1600/1600	2000/2000	4000/4000
690 VAC	AC-21 A / AC-21 B	800/800	1000/1000	1250/1250	1250/1250	1600/1600	2000/2000	-/3200
690 VAC	AC-22 A / AC-22 B	800/800	1000/1000	1250/1250	1250/1250	1600/1600	2000/2000	-/-
690 VAC	AC-23 A / AC-23 B	800/800	1000/1000	1250/1250	1250/1250	1250/1250	1600/1600	-/-

 Operational power in AC-23 A (kW) ⁽³⁾

At 690 VAC without pre-break AC	900	900	-	-	-	-	-
---------------------------------	-----	-----	---	---	---	---	---

Reactive power (kvar)

At 690 VAC (kvar)	550	750	950	950	-	-	-
-------------------	-----	-----	-----	-----	---	---	---

 Fuse protected short-circuit withstand (kA rms prospective) at 690 VAC⁽⁴⁾

Prospective short-circuit current (kA rms)	50	50	50	50	50	-	-
Associated fuse rating (A)	800	800	2 x 500	1250	2 x 800	-	-

Circuit breaker protected short-circuit withstand with any circuit breaker that ensures tripping in less than 0.3s at 690 VAC

Rated short-time withstand current 0.3s. I_{cw} (kA rms)	28	55	55	53	53	53	53
--	----	----	----	----	----	----	----

Short-circuit capacity (without protection) at 690 VDC

Rated short-time withstand current 1s. I_{cw} (kA rms)	20	30	30	35	35	35	35
Rated short-circuit making capacity without fuses I_{cm} (prospective kA peak)	40	80	80	75	75	75	75

Connection

Maximum Cu cable cross-section (mm ²)	2 x 185	2 x 240					
Minimum Cu busbar cross-section (mm ²)	2 x 40 x 5	2 x 50 x 5	2 x 60 x 5	2 x 60 x 5	2 x 80 x 5	3 x 100 x 5	1 x 100 x 5
Maximum Cu cable cross-section (mm ²)	2 x 300	4 x 185	4 x 185	4 x 185	6 x 185		
Maximum Cu busbar width (mm)	63	63	63	100	100	100	
Tightening torque min/max (Nm)	40/45	40/45	40/45	40	40	40	40

Mechanical characteristics

Durability (number of operating cycles)	4000	4000	3000	4000	4000	3000	2000
Operating effort (Nm)	48	48	48	55	55	75	100
Weight of a 3 pole device (kg)	8	8	8	12	12	22	45
Weight of a 4 pole device (kg)	10	10	10	15	15	25	50

(1) Category with index A = frequent operation - Category with index B = infrequent operation.

(2) With terminal shrouds or phase barrier.

(3) The power value is given for information only, the current values vary from one manufacturer to another.

(6) For a rated operational voltage $U_e = 690$ VAC.

SIRCO

Load break switches for power distribution
from 125 to 5000 A

Dimensions - Front operation

SIRCO 125 to 630 A and SIRCO AC 200 to CD 630 A - B3 to B5

Direct front operation

External front operation

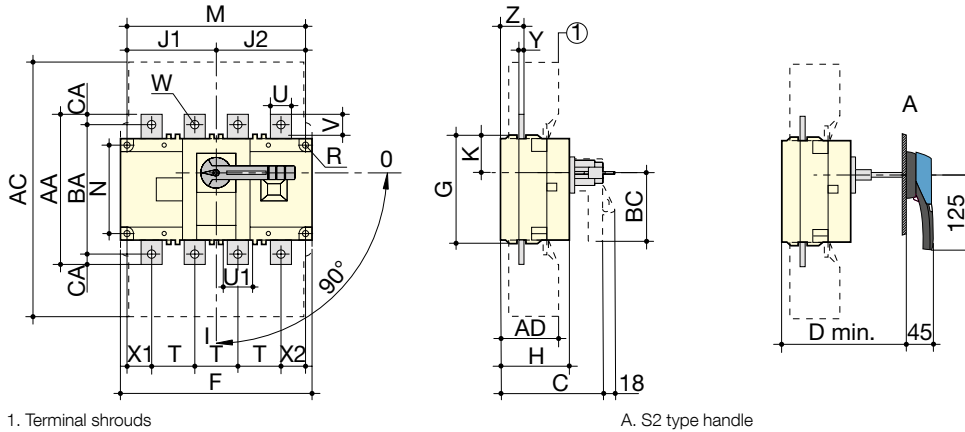

1. Terminal shrouds

A. S2 type handle

sirco_198_L1_x_cat

Rating (A) / Frame size		Overall dimensions		Terminal shrouds		Switch body						Switch mounting				Connection																			
SIRCO	SIRCO AC	C	D min	AC	AD	F 3p.	F 4p.	G	H	J1 3p.	J1 4p.	J2	K	BC	M 3p.	M 4p.	N	R	T	U	U1	V	W	X1 3p.	X1 4p.	X2	Y	Z	AA	BA	CA				
125...160 / B3		115	125	235	50	140	170	93	65	45	75	75	31.5	80	120	150	65	5.5	36	20	20.5	25	9	28	22	20	3.5	20.5	135	115	10				
200...250 / B4	200...250 / B4			280	60	180	230	108	75	55	105	105	34	115	160	210	80	5.5	50		20	25.5	21.5	11	33	33	27	3.5	22.5	160	130	15			
315...400 / B5	400...500 / B5	160	165	401	89	230	290	170	110	75	135	135	55	115	210	270	140	7	65		32	45.5	29	11			42.5	37.5	37.5	5	36	235	205	15	
500 / B5	-																																		
630 / B5	CD 630 / B5																																		

SIRCO 800 to 1800 A and SIRCO AC 630 to 1600 A - B6 to B7

Direct front operation

External front operation

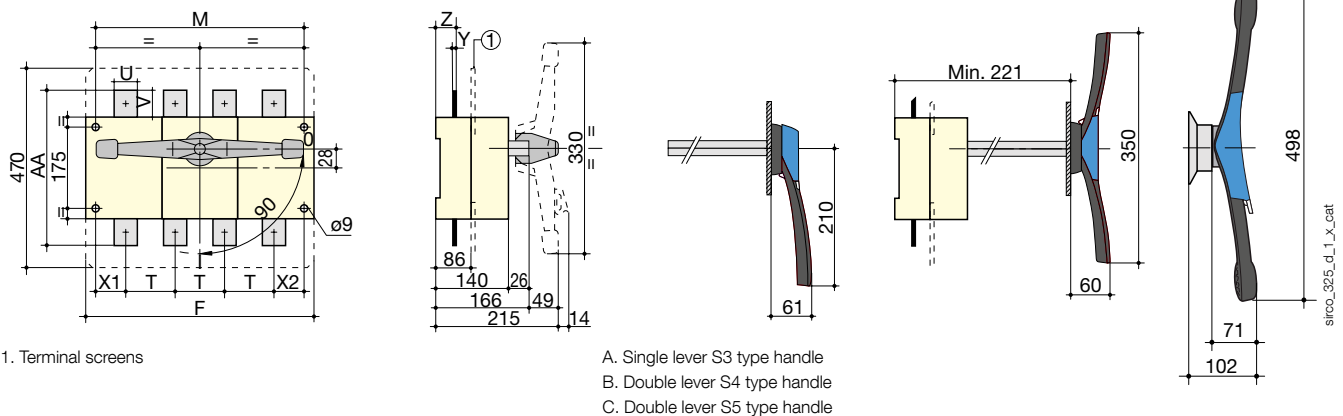

1. Terminal screens

A. Single lever S3 type handle
B. Double lever S4 type handle
C. Double lever S5 type handle

sirco_325_d_1_x_cat

Rating (A) / Frame size		Switch body		Switch mounting		Connection							
SIRCO	SIRCO AC	F 3p.	F 4p.	M 3p.	M 4p.	T	U	V	Y	X1	X2	Z	AA
800 ... 1000 / B6	630 ... 1000 / B6	280	360	255	335	80	50	60.5	7	47.5	47.5	46.5	321
CD 1250 / B6	CD 1250 / B6						60	65					330
1250 ... 1800 / B7	1250 ... 1600 / B7	372	492	347	467	120	90	44	8	53.5	53.5	47.5	288

SIRCO 2000 to 3200 A and SIRCO AC 2000 A - B8

Direct front operation

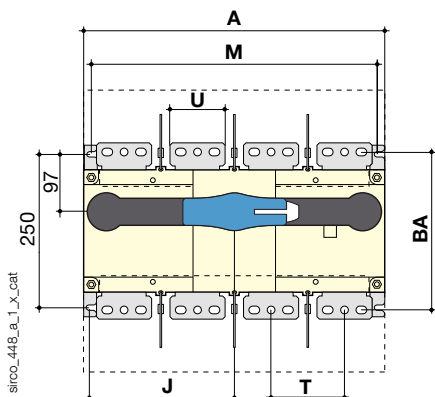

sirco_448_a_1_x_cat

External front operation

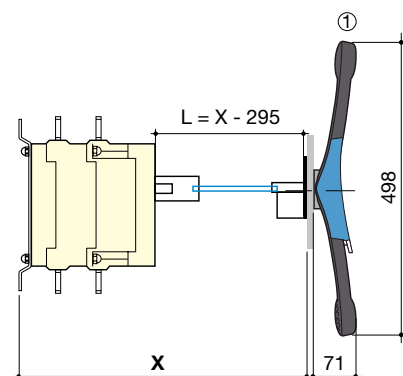

1. Double lever S5 type handle

Rating (A) / Frame size		Overall dimensions		Switch body		Switch mounting		Connection			
SIRCO	SIRCO AC	A 3p.	A 4p.	J 3p.	J 4p.	M 3p.	M 4p.	T	U	Y	BA
2000 ... 3200 / B8	2000 / B8	372	492	173.5	233.5	347	367	120	90	8	258

SIRCO 4000 to 5000 A and SIRCO AC 4000 A - B9

Direct front operation

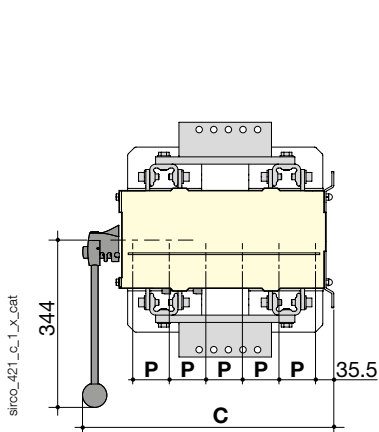

sirco_421_c_1_x_cat

External front operation

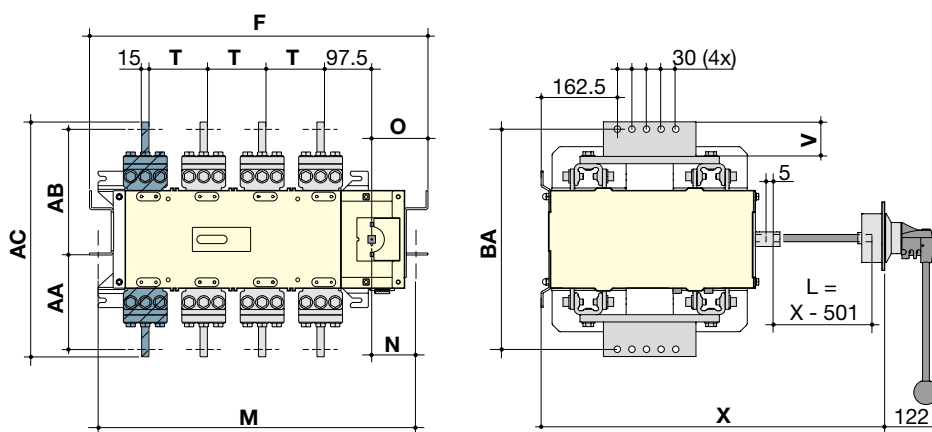

Rating (A) / Frame size		Overall dimensions	Switch body		Switch mounting					Connection					
SIRCO	SIRCO AC	C	F 3p.	F 4p.	M 3p.	M 4p.	N	O	P	T	V	AA	AB	AC	BA
4000 ... 5000 / B9	4000 / B9	514	695	695	660	660	98	115.5	75	120	86	160	292	482	452

SIRCO

Load break switches for power distribution
from 125 to 5000 A

Dimensions for external handles

B3 to B5

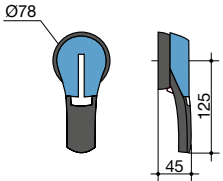
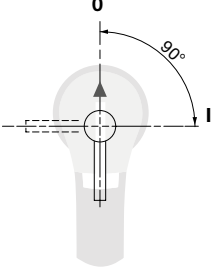
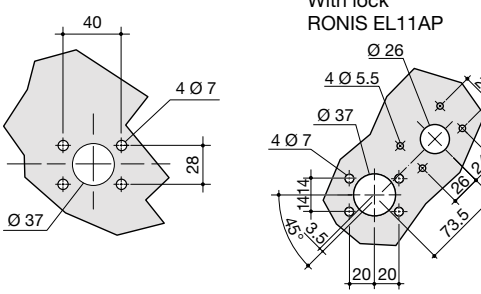
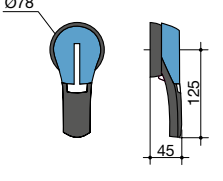
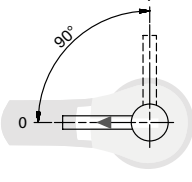
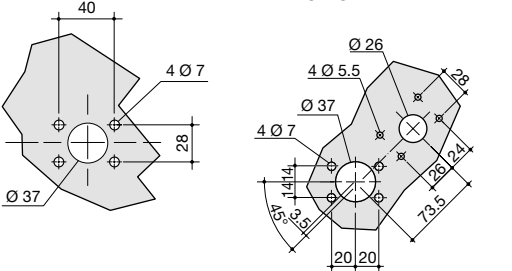
Handle type	Front operation Direction of operation	Door drilling
S2 type 		
S2 type 	Side operation Right side operation 	

B6 - B7

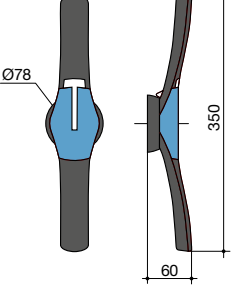
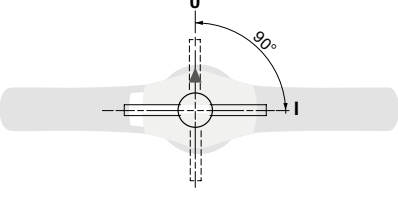
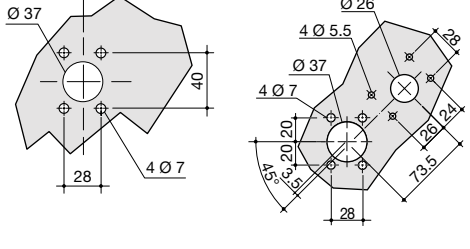
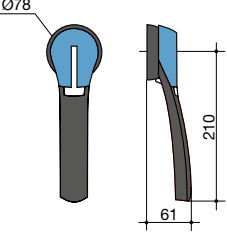
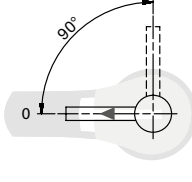
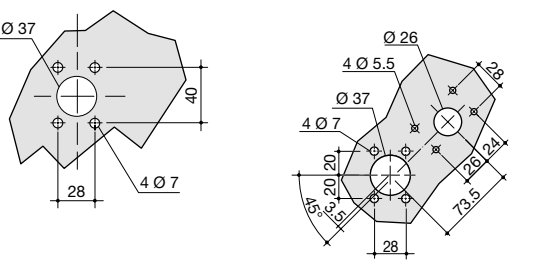
Handle type	Front operation Direction of operation	Door drilling
S4 type 		
S3 type 	Side operation Right side operation 	

B7 - B8

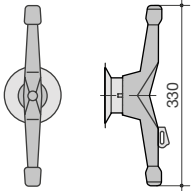
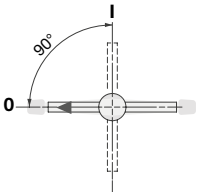
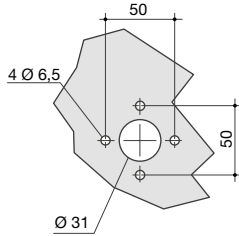
Handle type	Front operation Direction of operation	Door drilling
V2 Type 		

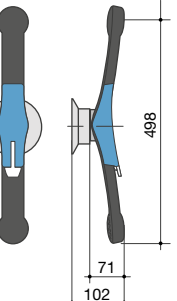
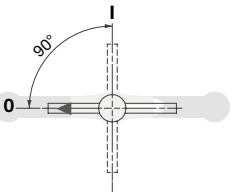
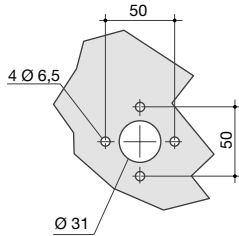
Handle type	Front operation Direction of operation	Door drilling
S5 type with V Escutcheon 		

B9

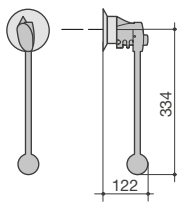
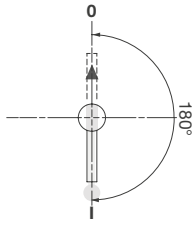
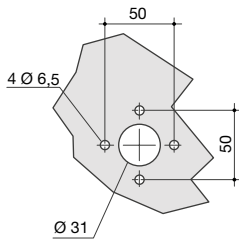
Handle type	Front operation Direction of operation	Door drilling
V0 type 		

SIRCO

Load break switches for power distribution
from 125 to 5000 A

Connection terminal

SIRCO 125 to 630 A and SIRCO AC 200 to CD 630 A

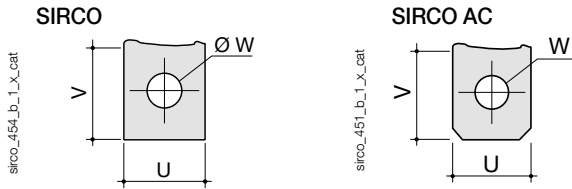

Rating (A)				
SIRCO	SIRCO AC	U	V	W
125 ... 160		20	25	9
200 ... 250	200 ... 250	25	21.5	11
	315	35		
315 ... 400	400 ... 500	32	29	13
500		45	41.5	
630	CD 630			

SIRCO 800 to 1000 A and SIRCO AC 630 to 1000 A

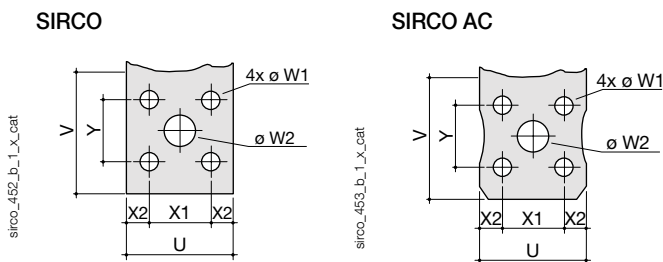

Rating (A)								
SIRCO	SIRCO AC	U	V	W1	W2	X1	X2	Y
800 ... 1000	630 ... 1000	50	60.5	9	15	33	8.5	33

SIRCO and SIRCO AC CD 1250 A

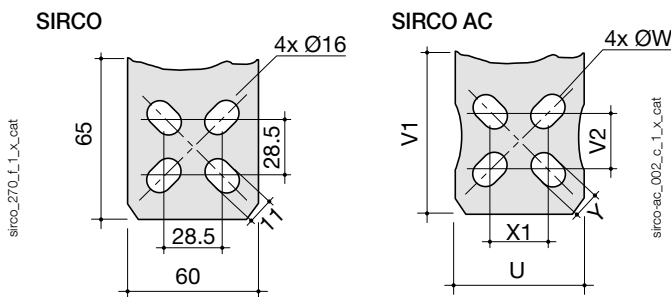

Rating (A)							
SIRCO	SIRCO AC	U	V1	V2	W	X1	Y
CD 1250 A	CD 1250 A	60	65	28.5	16	28.5	11

SIRCO 1250 to 3200 A and SIRCO AC 1250 to 1600 A

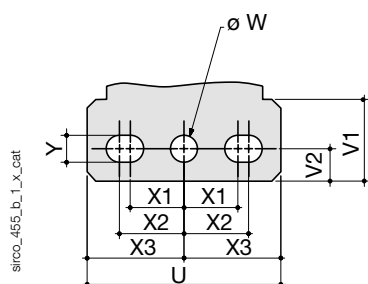

Rating (A)		U	V1	V2	W	X1	X2	X3	Y
SIRCO	SIRCO AC								
1250 ... 3200	1250 ... 1600	90	35.8	15	12.5	25	30	45	12.5

SIRCO 4000 to 5000 A and SIRCO AC 4000 A

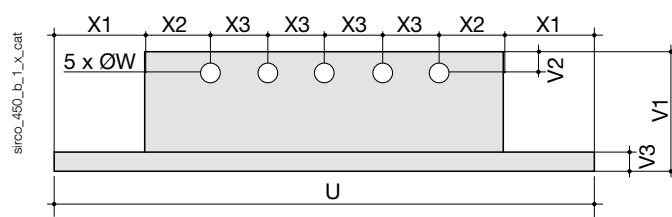

Rating (A)		U	W	X1	X2	X3	V1	V2	V3
SIRCO	SIRCO AC								
4000 ... 5000	4000	286	13	48	35	30	86	15	15

SIRCO PV IEC 60947-3

Load break switches for photovoltaic applications
from 100 to 3200 A, up to 1500 VDC



Function

SIRCO PV are manually operated multipolar load break switches. Making and breaking capacity under load conditions up to 1500 VDC. These extremely durable switches have been tested and approved for use in the most demanding applications. They have been designed and tested for all types of applications: earthing, floating or bipolar.

Advantages

Optimise your investment

- Thanks to a reduced number of bridging bars, you can limit your costs and save mounting time.
- A 2 pole SIRCO PV will reduce warming and can be placed in a smaller enclosure.

High quality materials

SIRCO PV is an extremely robust device in a glass fibre reinforced polyester frame. This material provides:

- high mechanical strength,
- stability to temperature variations (RTI of 130°C),
- high dielectric strength (high CTI / tested as per standard ASTM D 2303).

Take advantage of an innovative design

The SIRCO PV can be directly connected to up to four independent PV panel strings. The global solution cost is therefore reduced in comparison with the use of four distinct switches.

Reliability and performance

Our range of SIRCO PV load break switches is compliant to standards UL98B and IEC 60947-3. SIRCO PV have been tested to critical currents and at a 10 kA short-circuit during 50 ms without specific protection. The type of cable protection against voltage surges can therefore be selected.

The solution for

- > Combiner box
- > Recombiner box
- > Inverter



Strong points

- > Patented switching technology up to 500 VDC/pole
- > Positive break indication
- > Up to 1500 VDC as per characteristics by IEC 60947-3
- > Up to 4 branch circuits per switch

Conformity to standards

- > IEC 60947-3
- > IEC 60364-7-712
- > UL 98B⁽¹⁾



⁽¹⁾ Veuillez nous consulter.

Approvals and certifications⁽¹⁾





⁽¹⁾ Product reference on request.

Typical PV architecture

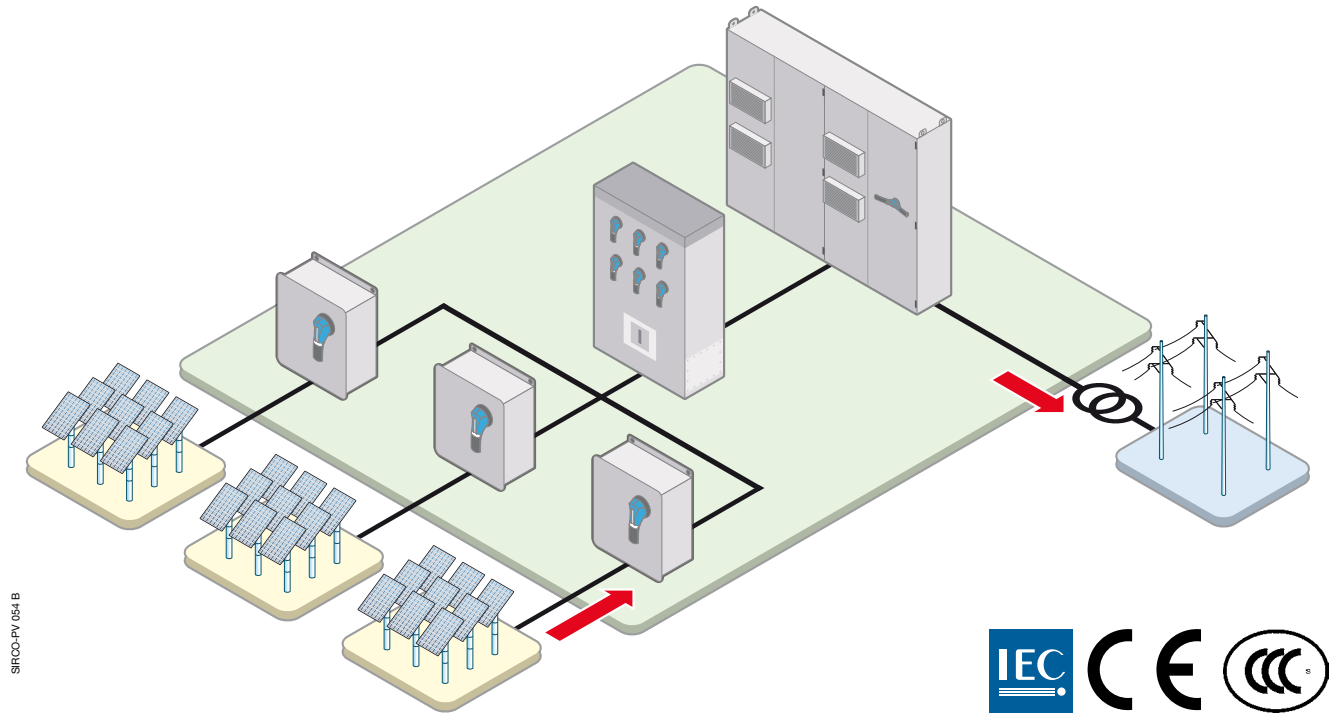
The SIRCO PV range provides safe disconnection and isolation at all levels within your PV installation.

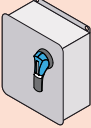

The SOCOMEC solutions

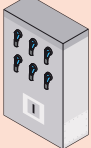
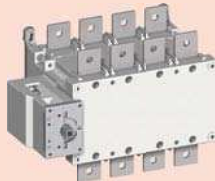
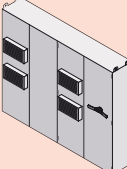
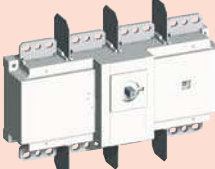
LEVEL OF INSTALLATION	SOCOMEK SOLUTIONS		
Combiner box			SIRCO PV One circuit up to 500 A at 1500 VDC
Recombiner box			SIRCO PV 4 circuits up to 500 A at 1000 VDC 2 circuits up to 500 A at 1500 VDC
Inverter			SIRCO PV One circuit up to 3200 A at 1000 VDC up to 2000 A at 1500 VDC

SIRCO PV IEC 60947-3

Load break switches for photovoltaic applications

from 100 to 3200 A, up to 1500 VDC

References

1000 VDC - Back plate mounting

Rating (A)	Frame size	Number of poles	Switch body	Direct handle	External handle	Shaft for external handle	Quantity to be ordered to connect 2 poles in series	
1 PV circuit								
100 A	B4	2 P	26PV 2010	J1 type Black 1112 1111 Red 1113 1111	S2 type ⁽¹⁾ Black IP55 1421 2111 Black IP65 1423 2111 Red IP65 1424 2111	200 mm 1400 1020 320 mm 1400 1032 400 mm 1400 1040	-	
160 A	B4	2 P	26PV 2016					
250 A	B4	2 P	26PV 2025					
315 A	B4	2 P	26PV 2031					
400 A	B4	4 P	26PV 4040					
500 A	B4	4 P	26PV 4050					
630 A	B5	4 P	26PV 4063					
800 A	B5	4 P	26PV 4080					
1250 A	B6	4 P	26PV 4120	C2 type Black 2799 7012 Red 2799 7013	S4 type ⁽¹⁾ Black IP65 1443 3111 Red IP65 1444 3111	200 mm 1401 1520 320 mm 1401 1532 400 mm 1401 1520	1x 2609 1100	
2000 A	B7	4 P	26PV 4200			2x 2609 1200		
3200 A	B8	4 P	Please consult us			V1 type Black IP65 2799 7145	320 mm 2799 3018 450 mm 2799 3019	Please consult us
2 PV circuits								
100 A	B4 _{DS}	4 P	26PV 5010	J2 type Black 1122 1111 Red 1123 1111	S2 type ⁽¹⁾ Black IP55 1421 2111 Black IP65 1423 2111 Red IP65 1424 2111	200 mm 1400 1020 320 mm 1400 1032 400 mm 1400 1040	-	
160 A	B4 _{DS}	4 P	26PV 5016					
250 A	B4 _{DS}	4 P	26PV 5025					
315 A	B4 _{DS}	4 P	26PV 5031					
400 A	B5	4 P	27PV 4032	J1 type Black 1112 1111 Red 1113 1111				1x 2709 0045
500 A	B5	4 P	27PV 4039					
630 A	B5 _{DS}	8 P	26PV 8063	J2 type Black 1122 1111 Red 1123 1111				
800 A	B6 _{DS}	8 P	26PV 8080	C2 type Black 2799 7012 Red 2799 7013				V1 type Black IP65 2799 7145
1250 A	B6 _{DS}	8 P	26PV 8120		1x 2609 1200			
2000 A	B7 _{DS}	8 P	26PV 8200					
4 PV circuits								
275 A	B5 _{DS}	8 P	27PV 8026	J2 type Black 1122 1111 Red 1123 1111	S2 type ⁽¹⁾ Black IP55 1421 2111 Black IP65 1423 2111 Red IP65 1424 2111	200 mm 1400 1020 320 mm 1400 1032 400 mm 1400 1040	4x 2709 0045	
400 A	B5 _{DS}	8 P	27PV 8032					
500 A	B5 _{DS}	8 P	27PV 8039					

(1) Defeatable handle.

1500 VDC - Back plate mounting

Rating (A)	Frame size	Number of poles	Switch body	Direct handle	External handle	Shaft for external handle	Quantity to be ordered to connect 2 poles in series
1 PV circuit							
275 A	B5	3 P	27PV 3026	J2 type Black 1122 1111 Red 1123 1111	S2 type ⁽¹⁾ Black IP55 1421 2111	200 mm 1400 1020	1x 2709 0027
400 A	B5	3 P	27PV 3032		Black IP65 1423 2111	320 mm 1400 1032	1x 2709 0045
500 A	B5	3 P	27PV 3039		Red IP65 1424 2111	400 mm 1400 1040	1x 2609 0080
630 A	B5 _{DS}	8 P	26PV 8063	C2 type Black 2799 7012 Red 2799 7013	V1 type Black IP65 2799 7145	320 mm 4199 3018	1x 2609 1100
800 A	B6 _{DS}	8 P	26PV 8080				
1250 A	B6 _{DS}	8 P	26PV 8120				
2000 A	B7 _{DS}	8 P	26PV 8200				
2 PV circuits							
275 A	B5 _{DS}	6 P	27PV 6026	J2 type Black 1122 1111 Red 1123 1111	S2 type ⁽¹⁾ Black IP55 1421 2111	200 mm 1400 1020	1x 2709 0027
400 A	B5 _{DS}	6 P	27PV 6032		Black IP65 1423 2111	320 mm 1400 1032	1x 2709 0045
500 A	B5 _{DS}	6 P	27PV 6039		Red IP65 1424 2111	400 mm 1400 1040	

(1) Defeatable handle.

Accessories

Direct operation handle

Frame size	Handle type	Handle colour	Reference
B4 ... B7	J1	Black	1112 1111
B4 ... B5	J1	Red	1113 1111
B6 ... B7	C2	Black	2799 7012
B6 ... B7	C2	Red	2799 7013
B4 _{DS} ... B5 _{DS}	J2	Black	1122 1111
B4 _{DS} ... B5 _{DS}	J2	Red	1123 1111
B4 _{DS} ... B7 _{DS}	C2	Black	2799 7012
B4 _{DS} ... B7 _{DS}	C2	Red	2799 7013



Door interlocked external operation handle

Use

Door interlocked external operation handles include an escutcheon, are padlockable and must be utilised with an extension shaft. In a combiner box, located close to the solar cell strings, or located close to the inverter, we recommend to use a door interlocked external handle for its safety features.

Example

The locking function of the enclosure in the "ON" position will force the operator to safely disconnect and isolate the solar cell strings prior to any intervention. Opening the door when the switch is on "ON" position is possible by defeating the locking function using a tool (authorised persons only). The interlocking function is restored when the door is re-closed.



Front operation

Frame size	Handle type	Handle colour	Degree of protection	Reference
B4 ... B5 - B4 _{DS}	S2	Black	IP55	1421 2111
B4 ... B5 - B4 _{DS}	S2	Black	IP65	1423 2111
B4 ... B5 - B4 _{DS}	S2	Red	IP65	1424 2111
B5 _{DS} - B6 ... B7	S4	Black	IP65	1443 3111
B5 _{DS} - B6 ... B7	S4	Red	IP65	1444 3111
B8 - B6 _{DS} - B7 _{DS}	V1	Black	IP65	2799 7145

SIRCO PV IEC 60947-3

Load break switches for photovoltaic applications
from 100 to 3200 A, up to 1500 VDC

Accessories (continued)

Shaft for external handle

Use

Standard lengths:

- 200 mm,
- 320 mm,
- 400 mm.

Other lengths: Please consult us.

Frame size	Handle type	Dimension Y (mm)	Length (mm)	Reference
B4	S2	150 ... 295	200	1400 1020
B4	S2	150 ... 415	320	1400 1032
B4	S2	150 ... 495	400	1400 1040
B5	S2	203 ... 328	200	1400 1020
B5	S2	203 ... 448	320	1400 1032
B5	S2	203 ... 525	400	1400 1040
B6	S4	220 ... 343	200	1401 1520
B6	S4	220 ... 463	320	1401 1532
B6	S4	220 ... 543	400	1401 1540
B7	S4	305 ... 366	200	1401 1520
B7	S4	305 ... 485	320	1401 1532
B7	S4	305 ... 564	400	1401 1540
B4 _{DS}	S2	305 ... 363	200	1400 1020
B4 _{DS}	S2	305 ... 485	320	1400 1032
B4 _{DS}	S2	305 ... 561	400	1400 1040
B5 _{DS}	S4	406 ... 467	200	1401 1520
B5 _{DS}	S4	406 ... 589	320	1401 1532
B5 _{DS}	S4	406 ... 668	400	1401 1540
B6 _{DS}	V1	508 ... 714	320	4199 3018
B6 _{DS}	V1	508 ... 795	400	4199 3019
B7 _{DS}	V1	508 ... 714	320	4199 3018
B7 _{DS}	V1	508 ... 795	400	4199 3019
B8	V1	415 ... 690	320	2799 3018
B8	V1	415 ... 820	450	2799 3019



access_144_b_1_cat

access_369_a_1_cat

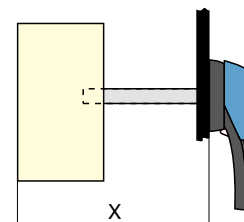

access_202_a_1_x_cat

Shaft guide for external operation

Use

To guide the shaft extension into the external handle.

Required for a shaft length over 320 mm.

This accessory enables the handle to engage the extension shaft with a misalignment of up to 15 mm.

Description	Reference
Shaft guide	1429 0000



access_260_a_2_cat

S-type handle adapter

Use

Enables S-type handles to be fitted in place of existing older style Socomec handles. Adapter can also be utilised as a spacer to increase the distance between the panel door and the handle lever.

Dimensions

Adds 12 mm to the depth of the handle.



access_187_a_1_cat

Handle colour	External IP ⁽¹⁾	To be ordered in multiples of	Reference
Black	IP65	1	1493 0000

(1) IP: protection degree according to IEC 60529 standard.

Alternative S-type handle cover colours

Use

For single lever handles type S1, S2, S3.

Other colours: Please consult us.



access_188_a_1_cat

Handle colour	Handle type	To be ordered in multiples of	Reference
Light grey	S1, S2, S3	50	1401 0001
Dark grey	S1, S2, S3	50	1401 0011
Light grey	S4	50	1401 0031
Dark grey	S4	50	1401 0041

Auxiliary contact

Use

Pre-break and signalling of positions 0 and I:

- 1 to 2 NO/NC auxiliary contacts,
- 1 to 4 NO + NC auxiliary contacts,
- 1 to 2 low level NO/NC auxiliary contacts.

Characteristics

NO/NC AC: IP2 with front operation.

Connection to the control circuit

By 6.35 mm fast-on terminal.

Electrical characteristics

30 000 operations.



access_076_a_1_cat

NO/NC changeover auxiliary contacts

Frame size	Position AC	Type	Reference
B4 ... B8	1 contact	NO/NC	2699 0031
B4 ... B8	2 contacts	NO/NC	2699 0032
B4 _{DS} ... B7 _{DS}	1 contact	NO/NC	2699 0061
B4 _{DS} ... B7 _{DS}	2 contacts	NO/NC	2699 0062

Low level NO/NC auxiliary contacts

Frame size	Position AC	Type	Reference
B4 ... B7	1 contact	NO/NC	2699 0301
B4 ... B7	2 contacts	NO/NC	2699 0302

NO+NC contact

Frame size	Position AC	Type	Reference
B4 ... B7	1 contact	NO + NC	2699 0061
B4 ... B7	2 contacts	NO + NC	2699 0062

Terminal screen

Use

Top and bottom protection against direct contact with terminals or connection parts.

Frame size	No. of poles	Position	Pack	Reference
B4	2 P	Top or bottom	1 unit	2698 3020
B4	4 P	Top or bottom	1 unit	2698 4020
B5	3 P	Top or bottom	1 unit	2698 3050
B5	4 P	Top or bottom	1 unit	2698 4050
B6	4 P	Top or bottom	1 unit	2698 4080
B7	4 P	Top or bottom	1 unit	2698 4120
B8	4 P	Top or bottom	1 unit	2698 4200
B4 _{DS}	2 P	Top or bottom	1 unit	1509 3025
B5 _{DS}	6 P	Top and bottom	2 units	1509 3063
B5 _{DS}	8 P	Top and bottom	2 units	1509 4063
B6 _{DS}	8 P	Top and bottom	2 units	1509 4080
B7 _{DS}	8P	Top and bottom	2 units	2698 4199



access_079_a_1_cat

SIRCO PV IEC 60947-3

Load break switches for photovoltaic applications

from 100 to 3200 A, up to 1500 VDC

Accessories (continued)

Bridging bars for connecting poles in series

Use

The bridging bars will make easy the connection of the poles in series, allowing the following configurations⁽¹⁾.

⁽¹⁾ Other connections: refer to mounting instructions.

1000 VDC

Frame size	Rating (A)	Quantity to be ordered to connect 2 poles in series	Fig.	Reference
1 PV circuit				
B4	100	-(1)	-	-(1)
B4	160	-(1)	-	-(1)
B4	250	-(1)	-	-(1)
B4	315	-(1)	-	-(1)
B4	400	2	1	2609 0025
B4	500	2	1	2609 0025
B5	630	1	2	2609 0080
B5	800	1	2	2609 0080
B6	1250	1	3	2609 1100
B7	2000	1	3	2609 1200
B8	3200			Consult us
2 PV circuits				
B4 _{DS}	100	-(1)	-	-(1)
B4 _{DS}	160	-(1)	-	-(1)
B4 _{DS}	250	-(1)	-	-(1)
B4 _{DS}	315	-(1)	-	-(1)
B5	400	1	4	2709 0045
B5	500	1	4	2709 0045
B5 _{DS}	630	1	2	2609 0080
B6 _{DS}	800	1	3	2609 1100
B6 _{DS}	1250	1	3	2609 1100
B7 _{DS}	2000	1	3	2609 1200
4 PV circuits				
B5 _{DS}	500	1	4	2709 0045

1500 VDC

Frame size	Rating (A)	Quantity to be ordered to connect 2 poles in series	Fig.	Reference
1 PV circuit				
B5	275	1	5	2709 0027
B5	315	1	5	2709 0027
B5	400	1	4	2709 0045
B5	500	1	4	2709 0045
B5 _{DS}	630	1	2	2609 0080
B6 _{DS}	800	1	3	2609 1100
B6 _{DS}	1250	1	3	2609 1100
B7 _{DS}	2000	1	3	2609 1200
2 PV circuits				
B5 _{DS}	275	1	5	2709 0027
B5 _{DS}	400	1	4	2709 0045
B5 _{DS}	500	1	4	2709 0045

⁽¹⁾ Bridging bars not needed.

Bridging bars for connecting poles in series (continued)

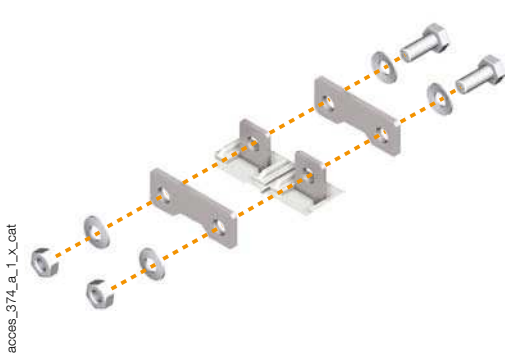

Fig. 1

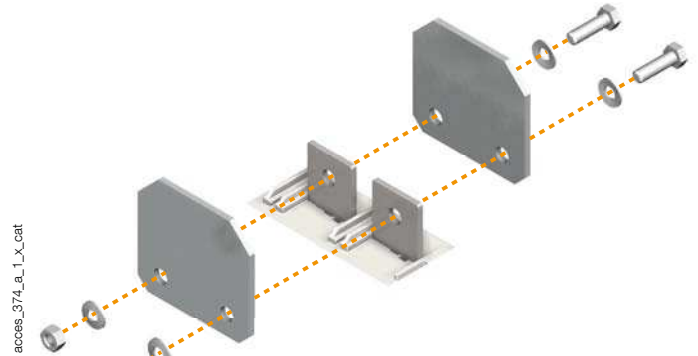

Fig. 2

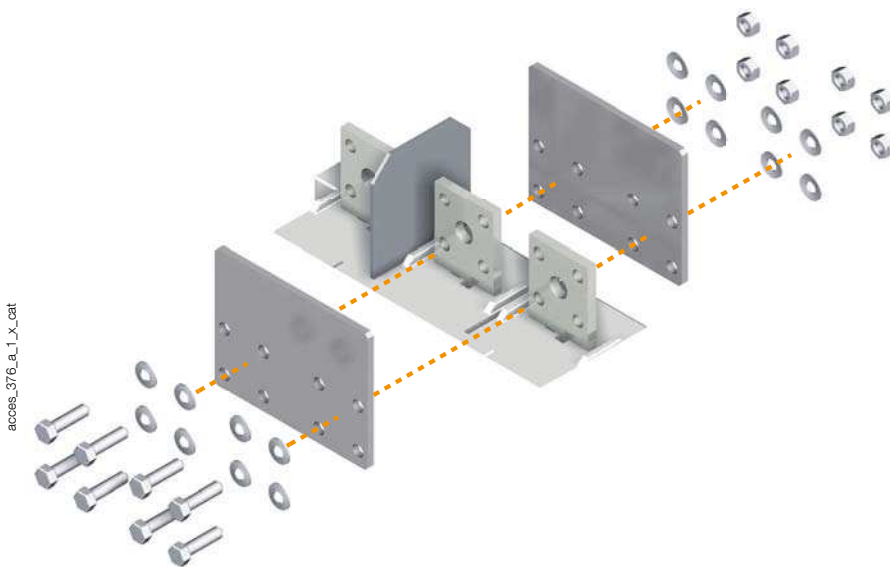

Fig. 3

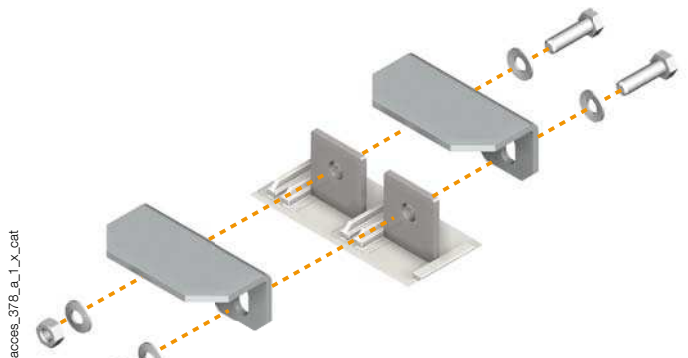

Fig. 4

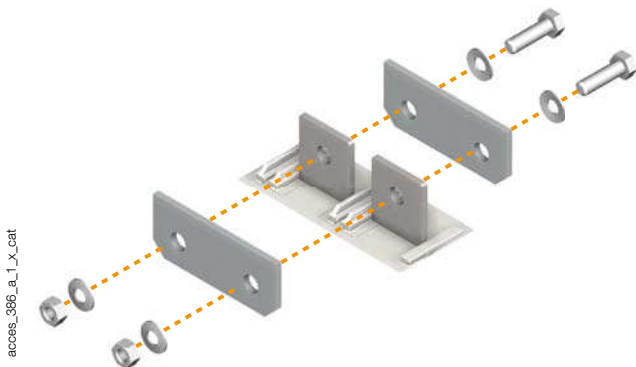

Fig. 5

SIRCO PV IEC 60947-3

Load break switches for photovoltaic applications

from 100 to 3200 A, up to 1500 VDC

Characteristics

Characteristics according to IEC 60947-3

Rated current In			100 A				160 A			
Thermal current at 40°C (A)			100				160			
Thermal current at 50°C (A)			100				160			
Thermal current at 60°C (A)			100				160			
Rated insulation voltage U _i (V)			1500				1500			
Rated impulse withstand voltage U _{imp} (kV)			12				12			
Number of circuits	Rated voltage	Utilisation category	I _e (A)	Number of pole(s) in series per circuit	Number of pole(s) of the device	Frame size	I _e (A)	Number of pole(s) in series per circuit	Number of pole(s) of the device	Frame size
1 circuit	1000 VDC	DC-21 B	100	1 P + ; 1 P	2 P	B4	160	1 P + ; 1 P	2 P	B4
1 circuit	1500 VDC	DC-21 B	100	3 P + ; 1 P -	4 P	B4 _{DS}	160	3 P + ; 1 P	4 P	B4 _{DS}
2 circuits	1000 VDC	DC-21 B	100	1 P + ; 1 P	4 P	B4 _{DS}	160	1 P + ; 1 P	4 P	B4 _{DS}
Short-circuit capacity (without protection)										
Rated short-time withstand current 0.3 s. (kA eff)			10				10			
Rated short-time withstand current 1 s. (kA eff)			5				5			
Connection										
Maximum Cu rigid cable cross-section (mm ²)			35				70			
Maximum Cu busbar width (mm)			32				32			
Tightening torque min (Nm)			20				20			
Tightening torque max (Nm)			26				26			
Mechanical characteristics										
Durability (number of operating cycles)			10 000				10 000			
Operating effort (Nm)			10				10			
Weight of a 2 pole device (kg)			1.8				1.8			
Weight of a 4 pole device (kg)			4.3				4.3			

Rated current In			250 A				275 A			
Thermal current at 40°C (A)			250				275			
Thermal current at 50°C (A)			250				275			
Thermal current at 60°C (A)			250				275			
Rated insulation voltage U _i (V)			1500				1500			
Rated impulse withstand voltage U _{imp} (kV)			12				12			
Number of circuits	Rated voltage	Utilisation category	I _e (A)	Number of pole(s) in series per circuit	Number of pole(s) of the device	Frame size	I _e (A)	Number of pole(s) in series per circuit	Number of pole(s) of the device	Frame size
1 circuit	1000 VDC	DC-21 B	250	1 P + ; 1 P	2 P	B4	275	1 P + ; 1 P -	3 P	B5
1 circuit	1500 VDC	DC-21 B	250	3 P + ; 1 P -	4 P	B4 _{DS}	275	2 P + ; 1 P -	3 P	B5
2 circuits	1000 VDC	DC-21 B	250	1 P + ; 1 P -	4 P	B4 _{DS}	275	1 P + ; 1 P -	6 P	B5 _{DS}
2 circuits	1500 VDC	DC-21 B	-	-	-	-	275	2 P + ; 1 P -	6 P	B5 _{DS}
4 circuits	1000 VDC	DC-21 B	-	-	-	-	275	1 P + ; 1 P -	8 P	B5 _{DS}
Short-circuit capacity (without protection)										
Rated short-time withstand current 0.3 s. (kA eff)			10				10			
Rated short-time withstand current 1 s. (kA eff)			5				5			
Connection										
Maximum Cu rigid cable cross-section (mm ²)			120				185			
Maximum Cu busbar width (mm)			32				32			
Tightening torque min (Nm)			20				20			
Tightening torque max (Nm)			26				26			
Mechanical characteristics										
Durability (number of operating cycles)			10 000				10 000			
Operating effort (Nm)			10				10			
Weight of a 2 pole device (kg)			1.8				-			
Weight of a 3 pole device (kg)			-				6			
Weight of a 4 pole device (kg)			4.3				-			
Weight of a 6 pole device (kg)			-				12.3			
Weight of an 8 pole device (kg)			-				15			

Characteristics according to IEC 60947-3 (continued)

Rated current In			315 A				400 A			
Thermal current at 40°C (A)			315				400			
Thermal current at 50°C (A)			315				400			
Thermal current at 60°C (A)			315				400			
Rated insulation voltage U _i (V)			1500				1500			
Rated impulse withstand voltage U _{imp} (kV)			12				12			
Number of circuits	Rated voltage	Utilisation category	I _e (A)	Number of pole(s) in series per circuit	Number of pole(s) of the device	Frame size	I _e (A)	Number of pole(s) in series per circuit	Number of pole(s) of the device	Frame size
1 circuit	1000 VDC	DC-21 B	315	1 P + ; 1 P -	2 P	B4	400	2 P + ; 2 P -	4 P	B4
1 circuit	1500 VDC	DC-21 B	315	2 P + ; 1 P -	3 P	B5	400	2 P + ; 1 P -	3 P	B5
2 circuits	1000 VDC	DC-21 B	315	1 P + ; 1 P -	4 P	B4 _{DS}	400	1 P + ; 1 P -	4 P	B5
2 circuits	1500 VDC	DC-21 B	-	-	-	-	400	2 P + ; 1 P -	6 P	B5 _{DS}
4 circuits	1000 VDC	DC-21 B	-	-	-	-	400	1 P + ; 1 P -	8 P	B5 _{DS}

Short-circuit capacity (without protection)

Rated short-time withstand current 0.3 s. (kA eff)	10	-
Rated short-time withstand current 1 s. (kA eff)	5	10
Rated peak withstand current (kA peak) ⁽¹⁾	30	30

Connection

Maximum Cu rigid cable cross-section (mm ²)	185	240
Maximum Cu busbar width (mm)	32	32
Tightening torque min (Nm)	20	20
Tightening torque max (Nm)	26	26

Mechanical characteristics

Durability (number of operating cycles)	10 000	5 000
Operating effort (Nm)	10	10
Weight of a 2 pole device (kg)	1.8	-
Weight of a 3 pole device (kg)	6	6 (B4) / 3.8 (B5)
Weight of a 4 pole device (kg)	4.3	2.3
Weight of a 6 pole device (kg)	-	12.3
Weight of an 8 pole device (kg)	-	15

(1) For a rated operational voltage U_o = 400 VAC.

Rated current In			500 A				630 A			
Thermal current at 40°C (A)			500				630			
Thermal current at 40°C (A)			500				630			
Thermal current at 60°C (A)			B4: 475 / B5: 500				560			
Rated insulation voltage U _i (V)			1500				1500			
Rated impulse withstand voltage U _{imp} (kV)			12				12			
Number of circuits	Rated voltage	Utilisation category	I _e (A)	Number of pole(s) in series per circuit	Number of pole(s) of the device	Frame size	I _e (A)	Number of pole(s) in series per circuit	Number of pole(s) of the device	Frame size
1 circuit	1000 VDC	DC-21 B	500	2 P + ; 2 P -	4 P	B5	630	2 P + ; 2 P -	4 P	B5
1 circuit	1500 VDC	DC-21 B	500	2 P + ; 1 P -	3 P	B5	630	4 P + ; 4 P -	8 P	B5 _{DS}
2 circuits	1000 VDC	DC-21 B	500	1 P + ; 1 P -	4 P	B5	630	2 P + ; 2 P -	8 P	B5 _{DS}
2 circuits	1500 VDC	DC-21 B	500	2 P + ; 1 P -	6 P	B5 _{DS}	-	-	-	-
4 circuits	1000 VDC	DC-21 B	500	1 P + ; 1 P -	8 P	B5 _{DS}	-	-	-	-

Short-circuit capacity (without protection)

Rated short-time withstand current 1 s. (kA eff)	10	10
--	----	----

Connection

Maximum Cu rigid cable cross-section (mm ²)	2x150	2x185
Maximum Cu busbar width (mm)	32	40
Tightening torque min (Nm)	20	40
Tightening torque max (Nm)	26	40

Mechanical characteristics

Durability (number of operating cycles)	5 000	5 000
Operating effort (Nm)	10	14.5
Weight of a 3 pole device (kg)	6 (B4) / 3.8 (B5)	-
Weight of a 4 pole device (kg)	2.3	3.8
Weight of a 6 pole device (kg)	12.3	-
Weight of an 8 pole device (kg)	15	15

(1) For a rated operational voltage U_o = 400 VAC.

SIRCO PV IEC 60947-3

Load break switches for photovoltaic applications

from 100 to 3200 A, up to 1500 VDC

Characteristics (continued)

Characteristics according to IEC 60947-3 (continued)

Rated current In	800 A	1250 A
Thermal current at 40°C (A)	800	1250
Thermal current at 50°C (A)	800	1250
Thermal current at 60°C (A)	B5: 650 / B6: 800	
Rated insulation voltage U _i (V)	1500	1500
Rated impulse withstand voltage U _{imp} (kV)	12	12

Number of circuits	Rated voltage	Utilisation category	I _e (A)	Number of pole(s) in series per circuit	Number of pole(s) of the device	Frame size	I _e (A)	Number of pole(s) in series per circuit	Number of pole(s) of the device	Frame size
1 circuit	1000 VDC	DC-21 B	800	2 P + ; 2 P -	4 P	B5	1250 A	2 P + ; 2 P -	4 P	B6
1 circuit	1500 VDC	DC-21 B	800	4 P + ; 4 P -	8 P	B6 _{DS}	1250 A	4 P + ; 4 P -	8 P	B6 _{DS}
2 circuits	1000 VDC	DC-21 B	800	2 P + ; 2 P -	8 P	B6 _{DS}	1250 A	2 P + ; 2 P -	8 P	B6 _{DS}

Short-circuit capacity (without protection)

Rated short-time withstand current 1 s. (kA eff)	10	10
--	----	----

Connection

Maximum Cu rigid cable cross-section (mm ²)	2x240	2x240
Maximum Cu busbar width (mm)	50	63
Tightening torque min (Nm)	40	40
Tightening torque max (Nm)	45	45

Mechanical characteristics

Durability (number of operating cycles)	5 000	4 000
Operating effort (Nm)	14.5	37
Weight of a 4 pole device (kg)	3.8	3.8
Weight of an 8 pole device (kg)	15	15

Rated current In	2000 A	3200 A
Thermal current at 40°C (A)	2000	3200
Thermal current at 50°C (A)	1850	3200
Thermal current at 60°C (A)	1600	2700
Rated insulation voltage U _i (V)	1500	
Rated impulse withstand voltage U _{imp} (kV)	12	

Number of circuits	Rated voltage	Utilisation category	I _e (A)	Number of pole(s) in series per circuit	Number of pole(s) of the device	Frame size	I _e (A)	Number of pole(s) in series per circuit	Number of pole(s) of the device	Frame size
1 circuit	1000 VDC	DC-21 B	2000 A	2 P + ; 2 P -	4 P	B7	3200 A	2 P + ; 2 P -	4 P	B8
1 circuit	1500 VDC	DC-21 B	2000 A	4 P + ; 4 P -	8 P	B7 _{DS}	-	-	-	-
2 circuits	1000 VDC	DC-21 B	2000 A	2 P + ; 2 P -	8 P	B7 _{DS}	-	-	-	-

Short-circuit capacity (without protection)

Rated short-time withstand current 1 s. (kA eff)	10	10
--	----	----

Connection

Maximum Cu busbar width (mm)	100	4 x 100 x 5
Tightening torque min (Nm)	40	40
Tightening torque max (Nm)	45	45

Mechanical characteristics

Durability (number of operating cycles)	4000	2000
Operating effort (Nm)	56	75
Weight of a 4 pole device (kg)	22	25
Weight of an 8 pole device (kg)	50	-

Pole connections in series

1 PV circuit - 1000 VDC

B4 - 2P

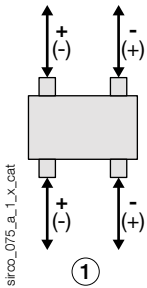

B4-B8 - 4P

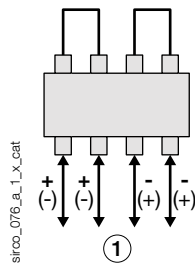

B5 - 3P

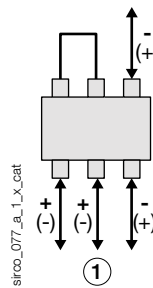

B5_{DS}-B7_{DS} - 8P

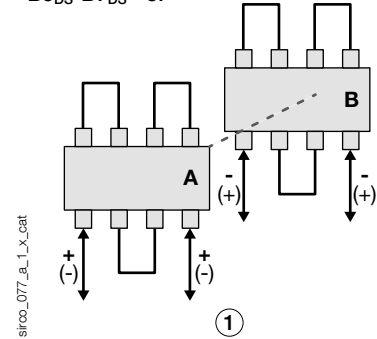

2 PV circuits - 1000 VDC

B4_{DS} - 4P

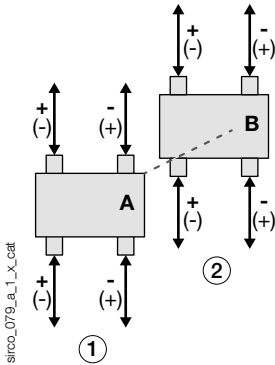

B5 - 4P

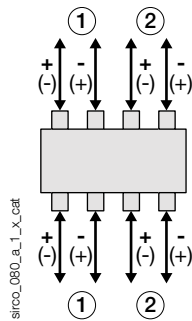

B5_{DS}-B7_{DS} - 8P

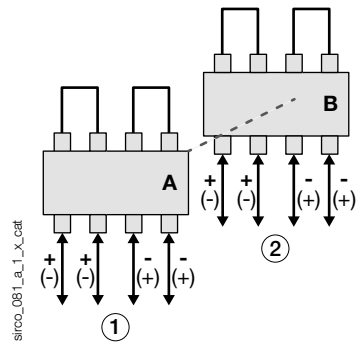

2 PV circuits - 1500 VDC

B5_{DS} - 6P

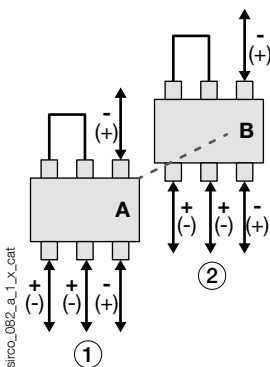

4 PV circuits - 1000 VDC

B5_{DS} - 8P

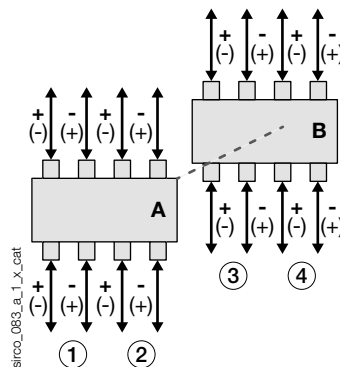

A. Front switch.
 B. Rear switch.

1. Utility 1
 2. Utility 2

3. Utility 3
 4. Utility 4

SIRCO PV IEC 60947-3

Load break switches for photovoltaic applications

from 100 to 3200 A, up to 1500 VDC

Dimensions (mm)

B4 - B5

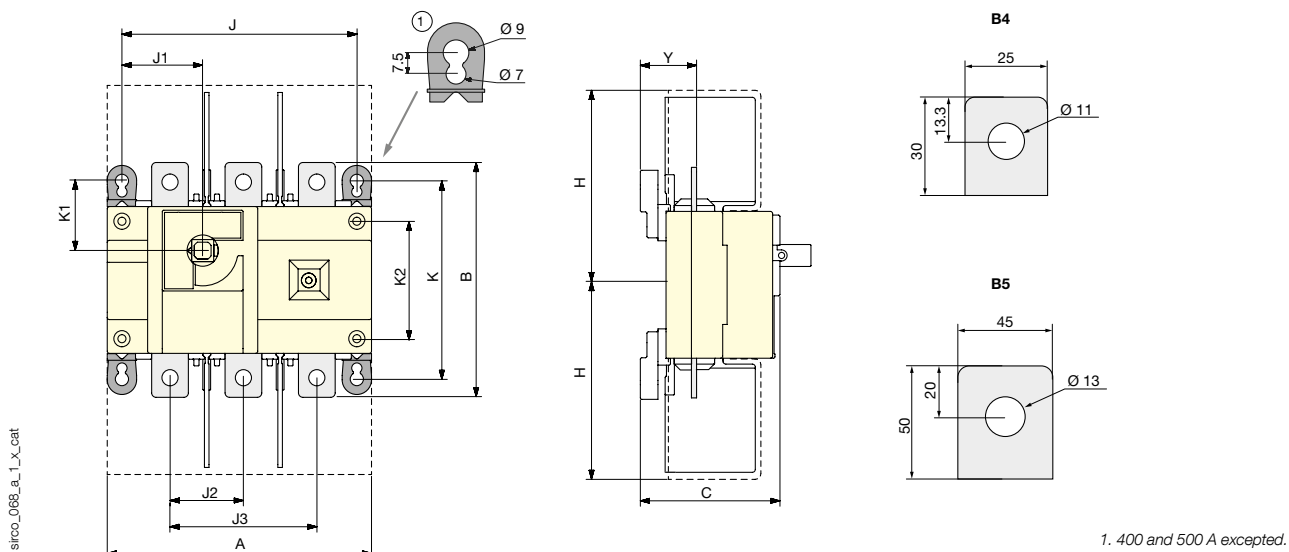

Frame size	No. of poles	A	B	C	H	J	J1	J2	J3	K	K1	K2	Y
B4	2 P	180	160	95	132.5	160	55	-	100	135	48	80	38.5
B4	4 P	230	170	79	132.5	210	105	50	-	-	-	80	22.5
B5	2 P	230	260	128	203	210	75	-	130	195	67.5	80	53
B5	3 P	230	260	126.5	203	210	75	65	-	195	67.5	80	51.5
B5	4 P	290	260	126.5	203	270	135	65	-	195	67.5	80	51.5

B4_{DS} - B5_{DS}

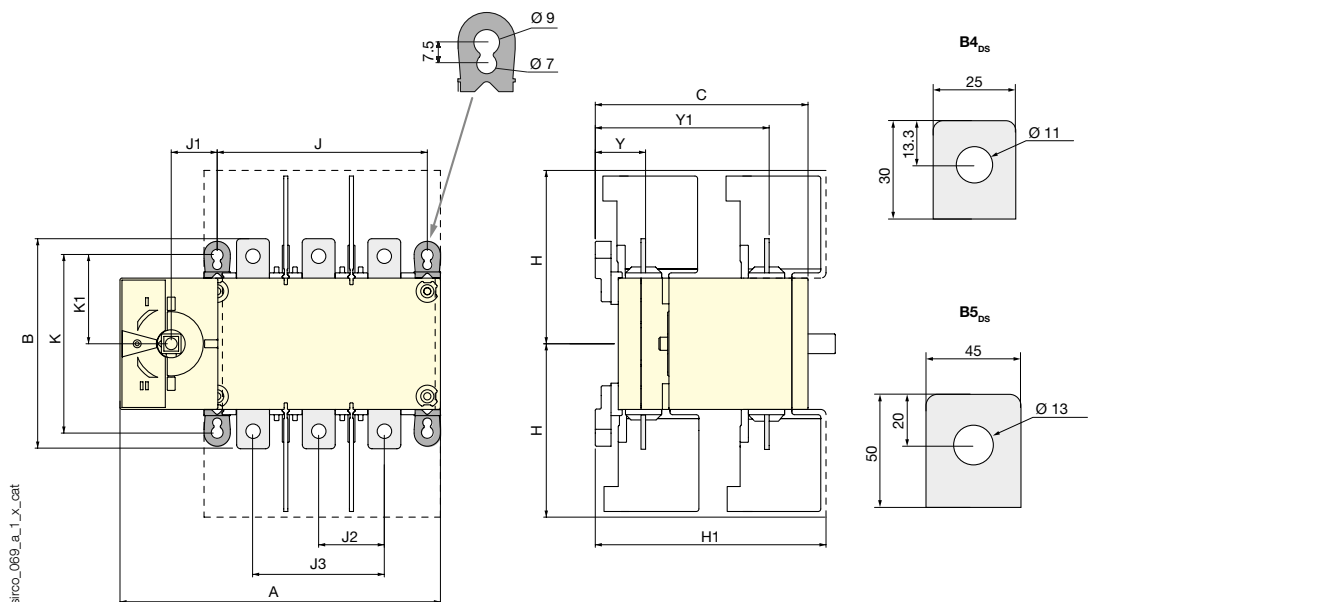

Frame size	No. of poles	A	B	C	H	H1	J	J1	J2	J3	K	K1	Y	Y1
B4 _{DS}	4 P	244	160	162	129	176	160	35	-	100	135	67.5	38.5	132.5
B5 _{DS}	6 P	301	260	238.5	203	165.5	210	35	65	-	195	68.5	51.5	189
B5 _{DS}	8 P	361	260	238.5	203	165.5	270	35	65	-	195	68.5	51.5	189

B6

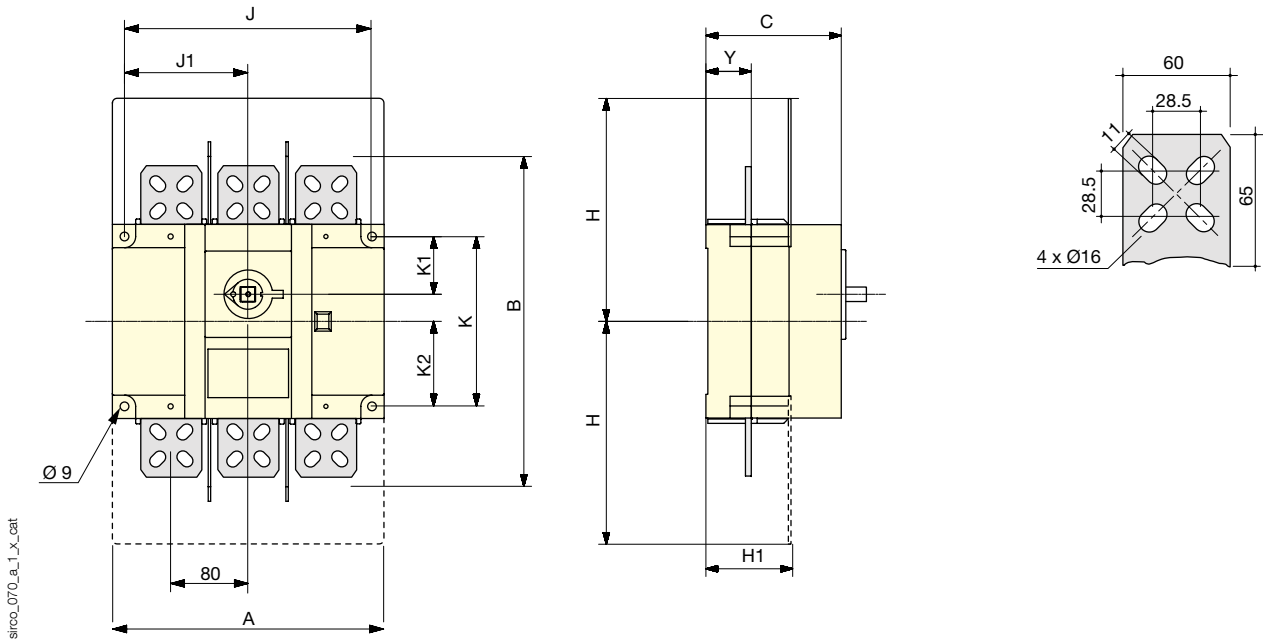

sirco_070_a_1_x_cat

Frame size	No. of poles	A	B	C	H	H1	J	J1	K	K1	K2	Y
B6	4 P	630	340	139	270	145	335	167.5	175	59.5	28	46.5

B6_{DS}

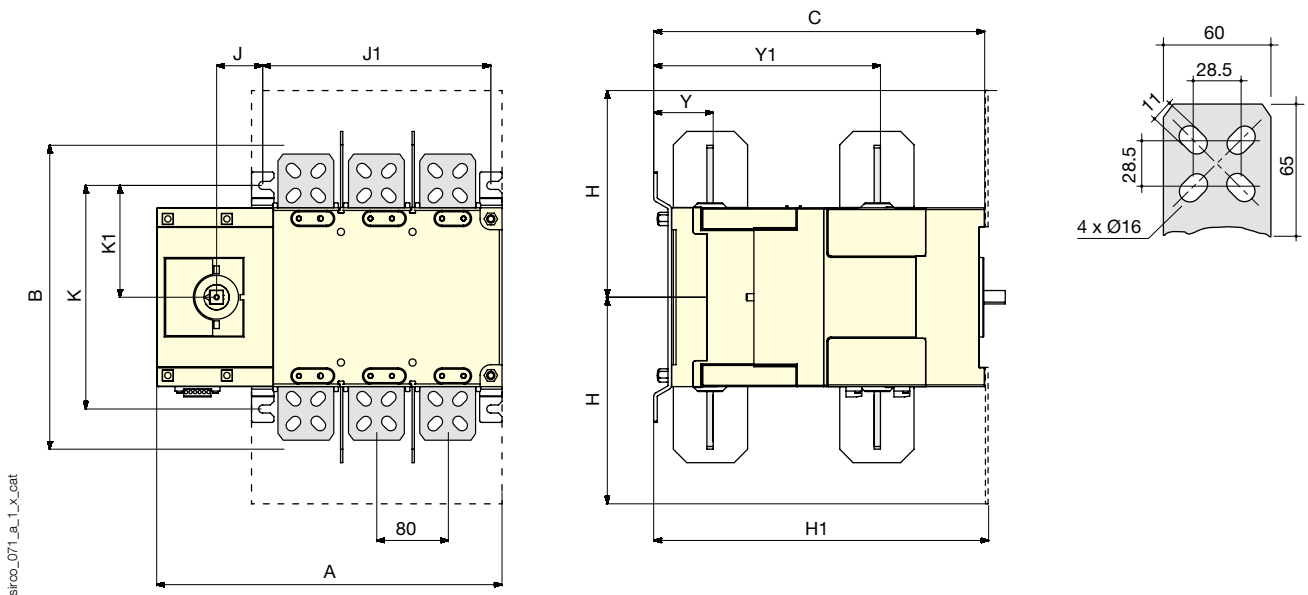

sirco_071_b_1_x_cat

Frame size	No. of poles	A	B	C	H	H1	J	J1	K	K1	Y	Y1
B6 _{ds}	8 P	466	340	370	270	347	335	51.5	250	125	66.5	253.5

SIRCO PV IEC 60947-3

Load break switches for photovoltaic applications
from 100 to 3200 A, up to 1500 VDC

Dimensions (mm) (continued)

B7

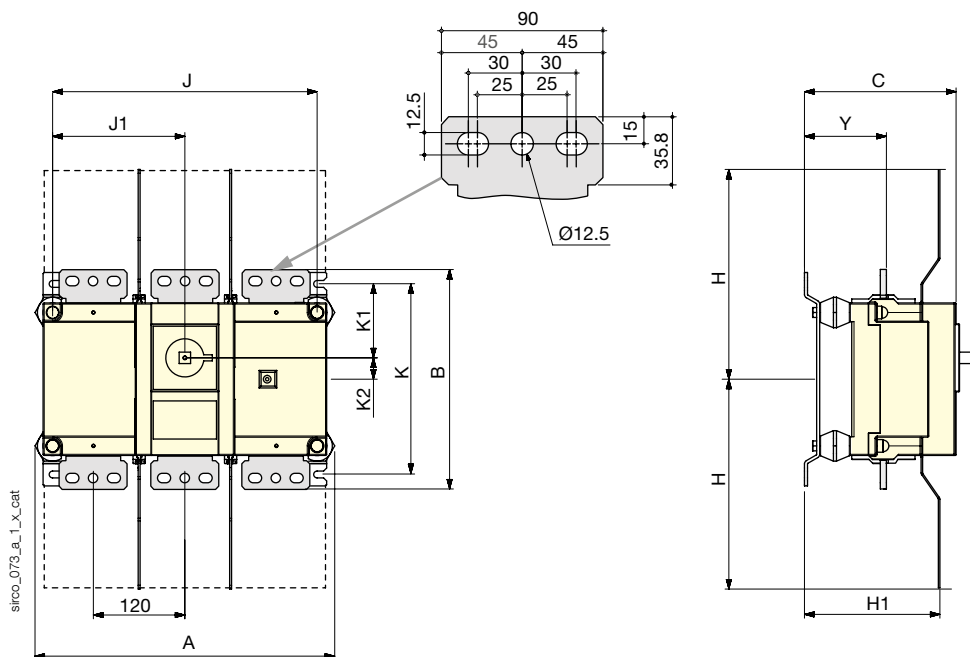

Frame size	No. of poles	A	B	C	H	H1	H2	J	J1	K	K1	K2	Y
B7	4 P	513	288	200	302	211	203.5	467	233.5	250	97	28	107.5

B7_{DS}

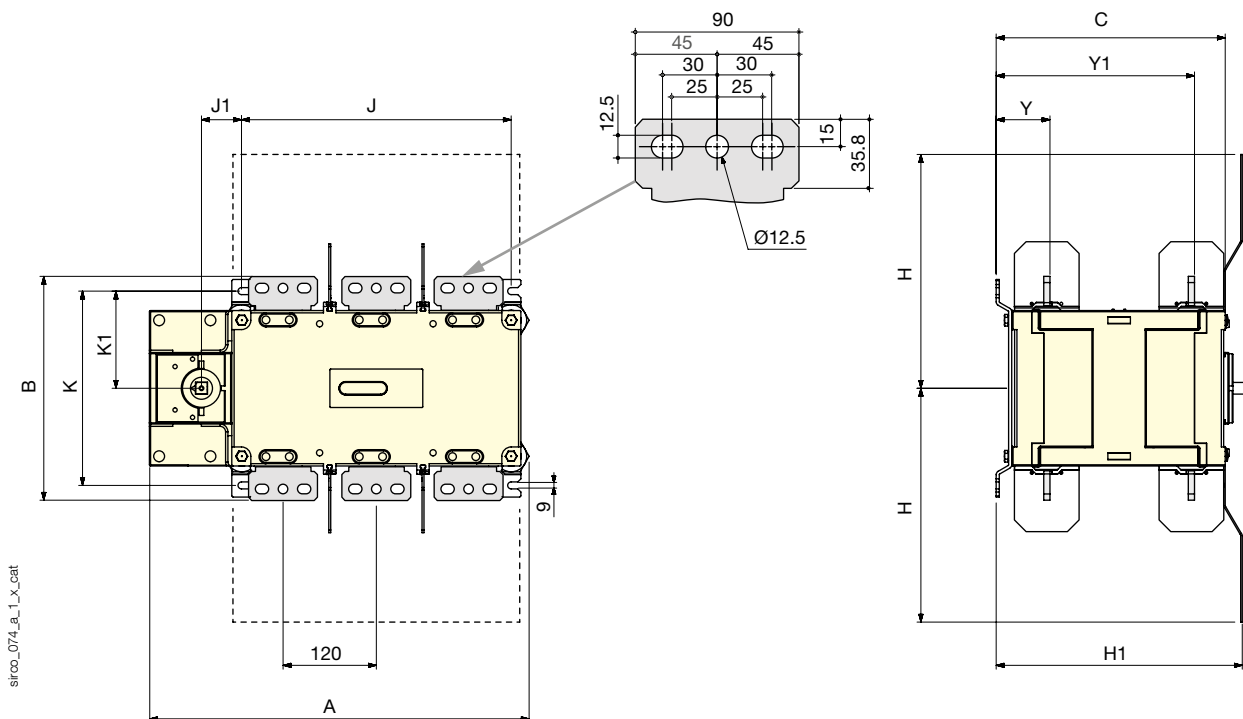

Frame size	No. of poles	A	B	C	H	H1	J	J1	K	K1	Y	Y1
B7 _{DS}	8 P	608.5	288	333	301	389	467	51.5	250	125	107.5	293.5

Dimensions of SIRCO PV 3200A - 1000 VDC - B8, please consult us.

Dimensions for external handles (mm)

B4 - B4_{DS} - B5

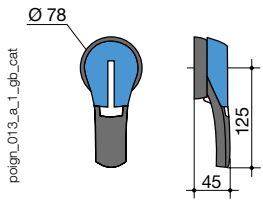
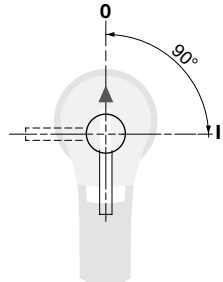
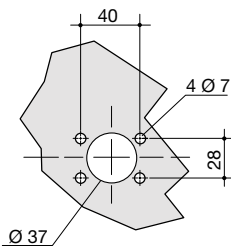
Handle type	Front operation Direction of operation	Door drilling
<p>S2 type</p> 		

B5_{DS} - B6 - B7

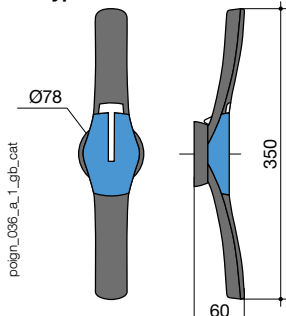
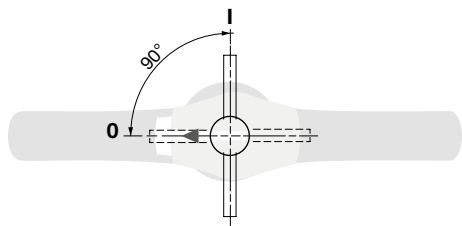
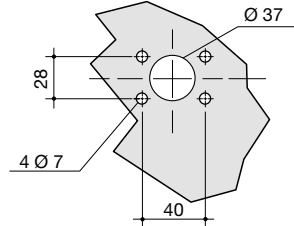
Handle type	Front operation Direction of operation	Door drilling
<p>S4 type</p> 		

B8 - B6_{DS} - B7_{DS}

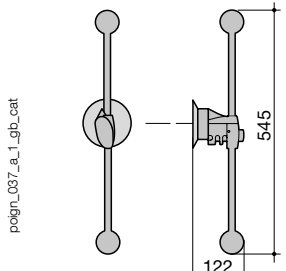
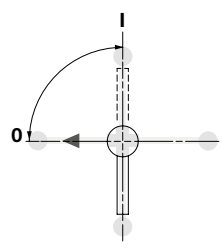
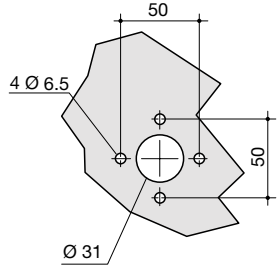
Handle type	Front operation Direction of operation	Door drilling
<p>V1 type</p> 		

SIRCO PV IEC 60947-3

Load break switches for photovoltaic applications
from 100 to 3200 A, up to 1500 VDC

Bridging bars (mm)

B4

2609 0025

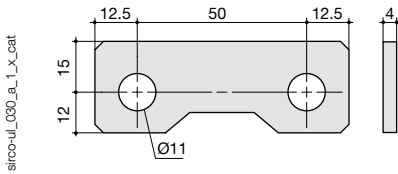

B5 - B5_{DS}

2709 0045

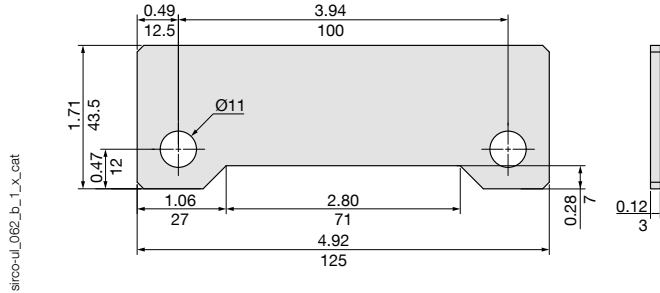

B5

2609 0080

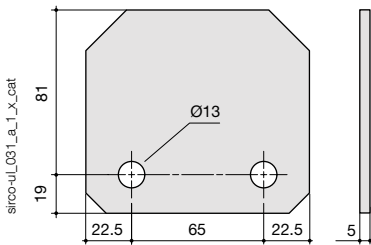

2709 0027

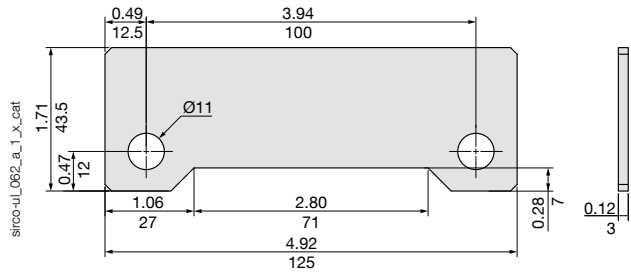

B6

2609 1100

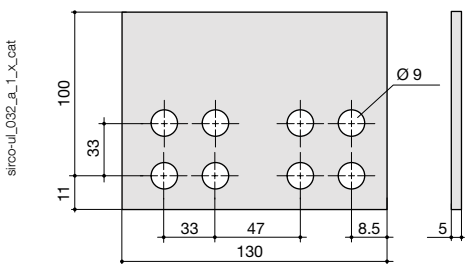

B7

2609 1200

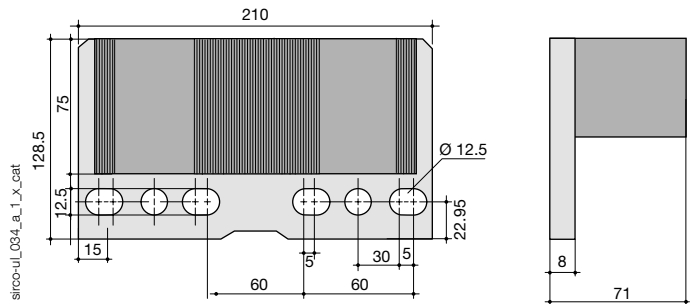

Mounting orientation

All frames

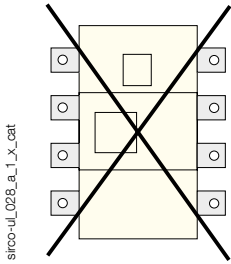

B4_{DS} - B5_{DS}

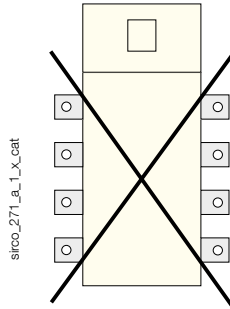

B6_{DS} - B7_{DS}

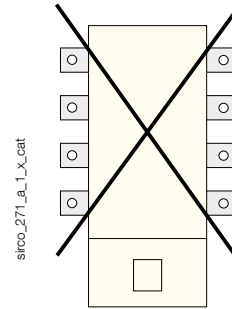



FUSERBLOC

Fuse combination switches
for industrial fuses up to 1250 A

Fuse protection



FUSERBLOC
630 to 1250 A



FUSERBLOC
32 to 400 A



FUSERBLOC
20 to 32 A

The solution for

- > Motor load break
- > Protection of industrial processes



Strong points

- > Improved safety
- > High breaking capacity
- > Specific functionalities for simplified use

A complete range

- > Centred or left side operation, rear connections, plug-in connections. Please consult us.

Conformity to standards

- > IEC 60947-3
- > EN 60947-3
- > BS EN 60947-3
- > NBN EN 60947-3
- > IEC 60269-1
- > DIN EN 60269-1
- > NF EN 60269-1
- > IEC 60269-2
- > VDE 0636-1
- > VDE 0660-107
- > Standards UL: see FUSERBLOC UL



Function

FUSERBLOC are manually operated multipolar fuse combination switches. They make and break on load and provide safety isolation and protection against overcurrent for any low voltage electrical circuit.

Advantages

Improved safety

- Complete isolation of the fuse with double breaking per pole (top and bottom of fuse).
- Positive break indication.
- IP2X protection with terminal shrouds front panel.

High breaking capacity

Protection against overloads and short-circuits thanks to high breaking capacity fuses (100 kA rms).

Specific functionalities for simplified use

- TEST position for testing control circuits without energising the power poles using U-type auxiliary contacts. In TEST position, the enclosure door can be opened.
- Mechanical or electronic fuse melting detection system (see DDMM or FMD page 270).

Customised solutions

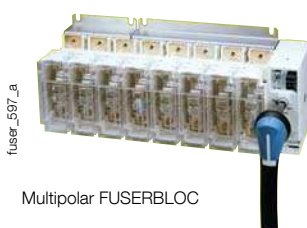

Multipolar FUSERBLOC



Centred operation

Approvals and certifications⁽¹⁾



LOVAG



Lloyd's Register

(1) Product reference on request.

What you need to know

- In addition to the FUSERBLOC rating, product selection also depends on the fuse characteristics and functional specifications, which need to be in accordance with the application. SOCOMEC FUSERBLOC are available for utilisation with **NFC, DIN or BS88 fuses**.

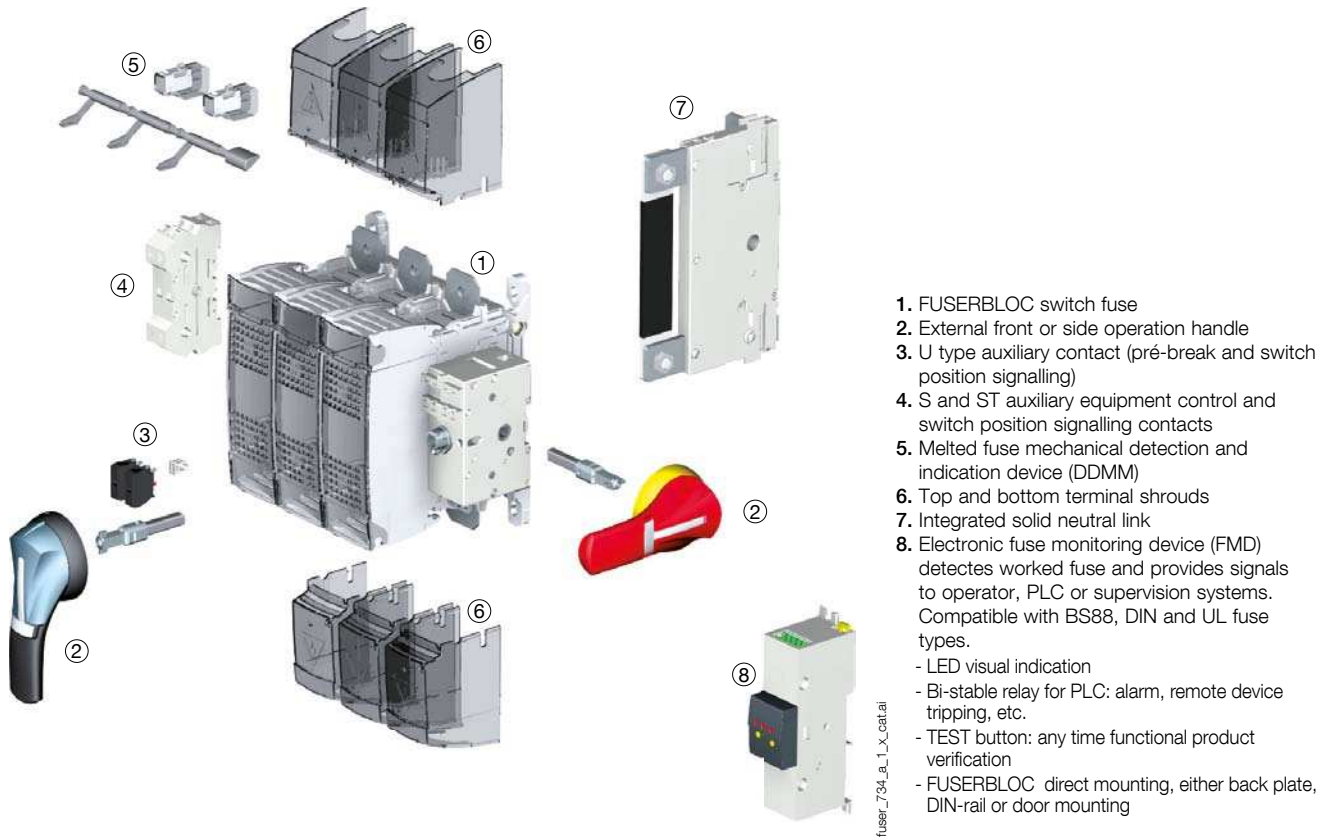

- FUSERBLOC switch fuse
- External front or side operation handle
- U type auxiliary contact (pré-break and switch position signalling)
- S and ST auxiliary equipment control and switch position signalling contacts
- Melted fuse mechanical detection and indication device (DDMM)
- Top and bottom terminal shrouds
- Integrated solid neutral link
- Electronic fuse monitoring device (FMD) detects worked fuse and provides signals to operator, PLC or supervision systems. Compatible with BS88, DIN and UL fuse types.
 - LED visual indication
 - Bi-stable relay for PLC: alarm, remote device tripping, etc.
 - TEST button: any time functional product verification
 - FUSERBLOC direct mounting, either back plate, DIN-rail or door mounting

- Whether it is 3 pole + switched neutral or 3 pole + solid neutral, the **FUSERBLOC 20 to 32 A with direct front operation and external operation** is the best suited solution in compact design.



- From 32 to 400 A, the FUSERBLOC is available in 2, 3 or 4 poles with **direct right side operation**.



- For ratings 20 to 400 A, the **flat mounting kit** provides a compact solution ideally suited to withdrawable applications.
- Maintenance of outputs from the DC common bus.



FUSERBLOC

Fuse combination switches

for industrial fuses up to 1250 A

References

BS 88 - External front and side operation - 20 to 160 A

Rating (A) Fuse size Frame size	Number of poles	Reference Switch I - 0 - TEST	Reference Changeover I - 0 - II	External front handle I - 0	TEST External front handle I - 0 - TEST	External right side handle I - 0	Changeover external front handle I - 0 - II	Shaft extensions for handle	Terminal shrouds ⁽³⁾	U type A/C ⁽²⁾	Integrated solid neutral link
CD 20 A A1 0	3 P	3641 3000	3680 3000					320 mm 1401 0532			
	3 P + switched neutral	3641 4000	3680 4000								
	3 P+solid neutral	3641 5000									
CD 32 A A1 0	3 P	3641 3001	3680 3001					IP2x as standard			
	3 P + switched neutral	3641 4001	3680 4001	S1 type	S1 type	S1 type	S1 type				
	3 P + solid neutral	3641 5001		Black IP65 1413 2111 ⁽¹⁾	Black IP65 1413 2115 ⁽¹⁾	Black IP65 1417 2111 ⁽¹⁾	Black IP65 1413 2113 ⁽¹⁾				
32 A A1 11	2 P	3841 2003									
	3 P	3841 3003	3880 3003	Red/Yellow IP65 1414 2111	Red/Yellow IP65 1414 2115	Red/Yellow IP65 1418 2111	Red/Yellow IP65 1414 2113				
	4 P	3841 6003	3880 6003								
63 A A2-A3 12	2 P	3841 2006								1 contact NO 3999 0701	3829 9310
	3 P	3841 3006	3880 3006								
	4 P	3841 6006	3880 6006								
100 A A4 ⁽⁴⁾ 13	2 P	3841 2010						320 mm 1400 1032		1 contact NC 3999 0702	
	3 P	3841 3010	3880 3010								
	4 P	3841 6010	3880 6010								
CD 160 A A3-A4 ⁽⁴⁾ 13 A	2 P	3841 2014							2 P 3998 2016 3 P 3998 3016 4 P 3998 4016		
	3 P	3841 3014	3880 3014	S2 type	S2 type	S2 type	S2 type				
	4 P	3841 6014	3880 6014	Black IP65 1423 2111 ⁽¹⁾	Black IP65 1423 2115 ⁽¹⁾	Black IP65 1427 2111 ⁽¹⁾	Black IP65 1421 2113 ⁽¹⁾				
160 A A4 14	2 P	3841 2015									3829 9320
	3 P	3841 3015	3880 3015	Red/Yellow IP65 1424 2111	Red/Yellow IP65 1424 2115	Red/Yellow IP65 1428 2111	Red/Yellow IP65 1424 2113				
	4 P	3841 6015	3880 6015								
160 A B1-B2 14	2 P	3841 2016									
	3 P	3841 3016	3880 3016								
	4 P	3841 6016	3880 6016								

(1) Standard.

(2) 4 auxiliary contacts as standard without additional contact holder.

(3) Top/bottom.

(4) For fuse size A4: max diameter 31 mm.

BS 88 - External front and side operation - 200 to 1250 A

Rating (A) Fuse size Frame size	Number of poles	Reference Switch I - 0 - TEST	Reference Changeover I - 0 - II	External front handle I - 0	TEST External front handle I - 0 - TEST	External right side handle I - 0	Changeover external front handle I - 0 - II	Shaft extensions for handle	Terminal shrouds ⁽³⁾	U type A/C ⁽²⁾	Integrated solid neutral link	
CD 200 A A3-A4 (5) 13 A	2 P	3841 2019							2 P 3998 2016		3829 9320	
	3 P	3841 3019	3880 3019						3 P 3998 3016			
	4 P	3841 6019	3880 6019						4 P 3998 4016			
200 A B1-B2 15	2 P	3841 2021		S2 type	S2 type	S2 type	S2 type	320 mm 1400 1032	2 P 3998 2025		3829 9325	
	3 P	3841 3021	3880 3021						3 P 3998 3025			
	4 P	3841 6021	3880 6021						4 P 3998 4025			
250 A B1-B2-B3 15	2 P	3841 2024		Black IP65	Black IP65	Black IP65	Black IP65					
	3 P	3841 3024	3880 3024	1423 2111 ⁽¹⁾	1423 2115 ⁽¹⁾	1425 2111 ⁽¹⁾	1422 2113 ⁽¹⁾					
	4 P	3841 6024	3880 6024	Red/Yellow IP65	Red/Yellow IP65	Red/Yellow IP65	Red/Yellow IP65					
315 A B1-B2-B3 16	2 P	3841 2031		1424 2111	1424 2115	1428 2111	1424 2113					
	3 P	3841 3031	3880 3032 ⁽⁶⁾									2 P 3898 2040
	4 P	3841 6031	3880 6032 ⁽⁶⁾									
400 A B1-B2- B3-B4 16	2 P	3841 2038							4 P 3898 4040	1 contact NC 3999 0702	3829 9339	
	3 P	3841 3038										
	4 P	3841 6038										
630 A C1-C2 17	2 P	3821 2063		S3 type								
	3 P	3821 3063										Black IP65 1433 3111 ⁽¹⁾
	4 P	3821 6063										
800 A C1-C2-C3 17	2 P	3821 2080		Red/Yellow IP65 1434 3111			Black IP65 1437 3111 ⁽¹⁾	320 mm 1400 1232	2 P 3898 2080		3829 9308	
	3 P	3821 3080							Red/Yellow IP65 1438 3111			
	4 P	3821 6080										
1250 A D1 18	2 P	3821 2120		S4 type					3898 2120		3829 9312	
	3 P	3821 3120		Black IP65 1443 3111 ⁽¹⁾								
	4 P	3821 6120										

(1) Standard.

(2) 4 auxiliary contacts as standard without additional contact holder.

(3) Top/bottom.

(4) 8 AC as standard without support (the support is for 8 additional auxiliary contacts).

(5) For fuse size A4: max diameter 31 mm.

(6) Terminal shrouds: 3 P - 3998 3025, 4 P - 3998 4025.

FUSERBLOC

Fuse combination switches

for industrial fuses up to 1250 A

References (continued)

BS 88 - Direct operation - 20 to 160 A

Rating (A) Fuse size Frame size	Number of poles	Reference Side direct operation	Reference Direct front operation	Side direct handle	Direct front handle	Auxiliary contacts	Terminal shrouds ⁽³⁾	Cage terminals	Handle key interlocking accessories ⁽²⁾
CD 20 A A1 0	3 P		3641 3000	Black 3629 4012	Black 3629 4012	1 contact NO/NC A-type 3999 0001⁽¹⁾	IP2x as standard	Standard	
	3 P + switched neutral		3641 4000						
	3 P + solid neutral		3641 5000						
CD 32 A A1 0	3 P		3641 3001						
	3 P + switched neutral		3641 4001						
	3 P + solid neutral		3641 5001						
32 A A1 1	2 P	3625 2003	consult us	Black 3629 7900					3629 7903
	3 P	3625 3003	consult us						
	4 P	3625 6003	consult us						
63 A A2-A3 2	2 P	3625 2006	consult us						
	3 P	3625 3006	consult us						
	4 P	3625 6006	consult us						
100 A A4 ⁽⁴⁾ 3	2 P	3625 2010	consult us	Black 3629 7901		1 contact NO/NC A-type 3999 0021⁽¹⁾			
	3 P	3625 3010	consult us						
	4 P	3625 6010	consult us						
CD 160 A A3-A4 ⁽⁴⁾ 3 A	2 P	3625 2014	consult us						
	3 P	3625 3014	consult us						
	4 P	3625 6014	consult us						
160 A A4 4	2 P	3625 2015	consult us						
	3 P	3625 3015	consult us						
	4 P	3625 6015	consult us						
160 A B1-B2 4	2 P	3625 2016	consult us						
	3 P	3625 3016	consult us						
	4 P	3625 6016	consult us						

(1) Max. 2 contacts.

(2) Lock not included.

(3) Top/bottom.

(4) For fuse size A4: max diameter 31 mm.

BS 88 - Direct operation - 200 to 400 A

Rating (A) Fuse size Frame size	Number of poles	Reference Side direct operation	Reference Direct front operation	Side direct handle	Direct front handle	Auxiliary contacts	Terminal shrouds ⁽³⁾	Cage terminals	Handle key interlocking accessories ⁽²⁾
CD 200 A A3-A4 ⁽⁴⁾ 13 A	2 P	3625 2019	consult us	Black 3629 7901	consult us	1 contact NO/NC A-type 3999 0021 ⁽¹⁾ 2 contacts NO/NC A-type 3999 0022 ⁽¹⁾	2 P 3998 2016 3 P 3998 3016 4 P 3998 4016	3 P 5400 3016 4 P 5400 4016	3629 7913
	3 P	3625 3019	consult us						
	4 P	3625 6019	consult us						
200 A B1-B2 5	2 P	3625 2021	consult us						
	3 P	3625 3021	consult us						
	4 P	3625 6021	consult us						
250 A B1-B2-B3 5	2 P	3625 2024	consult us						
	3 P	3625 3024	consult us						
	4 P	3625 6024	consult us						
315 A B1-B2-B3 6	2 P	3625 2032	consult us						
	3 P	3625 3032	consult us						
	4 P	3625 6032	consult us						
400 A B1-B2-B3-B4 6	2 P	3625 2039	consult us						
	3 P	3625 3039	consult us						
	4 P	3625 6039	consult us						

(1) Max. 2 contacts.

(2) Lock not included.

(3) Top/bottom.

(4) For fuse size A4: max diameter 31 mm.

BS 88 - Direct operation - 630 to 1250 A

Rating (A) Fuse size Frame size	Number of poles	Reference Side direct operation	Reference Direct front operation	Side direct handle	Direct front handle	Auxiliary contacts	Terminal shrouds ⁽³⁾	Cage terminals	Handle key interlocking accessories ⁽²⁾	
630 A C1-C2 17	2 P	3821 2063	3821 2063	S3 type Black 3899 7911 + 1437 3111	Black 3899 6011	1 contact NO U-type 3999 0701 ⁽¹⁾	2 P 3898 2080 3 P 3898 3080 4 P 3898 4080			
	3 P	3821 3063	3821 3063							
	4 P	3821 6063	3821 6063							
800 A C1-C2-C3 17	2 P	3821 2080	3821 2080							
	3 P	3821 3080	3821 3080							
	4 P	3821 6080	3821 6080							
1250 A D1 18	2 P	3821 2120	3821 2120							
	3 P	3821 3120	3821 3120							
	4 P	3821 6120	3821 6120							
						Black 3899 7011	1 contact NC U-type 3999 0702 ⁽¹⁾	3898 2120 3898 3120 3898 4120		

(1) Max. number of U-type auxiliary contacts is 8.

(2) Lock not included.

(3) Top/bottom.

FUSERBLOC

Fuse combination switches

for industrial fuses up to 1250 A

References

NFC and DIN - External front and right side operation - 25 to 125 A

Rating (A) / Fuse / Frame size	No. of poles	Switch I - 0 - TEST	Changeover switch I - 0 - II	External front handle	TEST external front handle	External right side handle	Changeover external front handle	Shaft for external handle	Auxiliary contacts ⁽³⁾	Terminal shrouds ⁽²⁾	Integrated solid neutral link
CD 25 A 10 x 38 0	3 P	3631 3002 ⁽¹⁾	3670 3002								
	3 P + switched neutral	3631 4002 ⁽¹⁾	3670 4002								
	3 P + solid neutral	3631 5002 ⁽¹⁾									
CD 32 A 10 x 38 0	3 P	3631 3003	3670 3003	S1 type	S1 type	S1 type	S1 type	320 mm 1401 0532			
	3 P + switched neutral	3631 4003	3670 4003								
	3 P + solid neutral	3631 5003									
CD 32 A 14 x 51 0	3 P	3631 3004 ⁽¹⁾	3670 3004	Black IP65 1413 2111	Black IP65 1413 2115	Black IP65 1417 2111	Black IP65 1413 2113		IP2x as standard		
	3 P + switched neutral	3631 4004 ⁽¹⁾	3670 4004	Red/Yellow IP65 1414 2111	Red/Yellow IP65 1414 2115	Red/Yellow IP65 1418 2111	Red/Yellow IP65 1414 2113				
	3 P + solid neutral	3631 5004 ⁽¹⁾									
50 A 14 x 51 11	2 P	3831 2005							U-type	1 contact NO 3999 0701	
	3 P	3831 3005 ⁽¹⁾	3870 3005								
	4 P	3831 6005 ⁽¹⁾	3870 6005								
63 A 00C 12	2 P	3831 2006								1contact NC 3999 0702	
	3 P	3831 3006 ⁽¹⁾	3870 3006								
	4 P	3831 6006 ⁽¹⁾	3870 6006								
100 A 22 x 58 13	2 P	3831 2010		S2 type	S2 type	S2 type	S2 type	320 mm 1400 1032 ⁽²⁾			
	3 P	3831 3010 ⁽¹⁾	3870 3010								
	4 P	3831 6010 ⁽¹⁾	3870 6010								
125 A 22 x 58 13	2 P	3831 2011		Black IP65 1423 2111	Black IP65 1423 2115	Black IP65 1427 2111	Black IP65 1423 2113			2 P 3998 2016 3 P 3998 3016 4 P 3998 4016	3829 9310
	3 P	3831 3011	3870 3011	Red/Yellow IP65 1424 2111	Red/Yellow IP65 1424 2115	Red/Yellow IP65 1428 2111	Red/Yellow IP65 1424 2113				
	4 P	3831 6011	3870 6011								
125 A 00 13	2 P	3831 2012									
	3 P	3831 3012	3870 3012								
	4 P	3831 6012	3870 6012								

(1) Available enclosed (see page "Enclosed fuse switches" page 730).

(2) Top/bottom.

(3) Maximum 4 contacts.

NFC and DIN - External front and right side operation - 160 to 1250 A

Rating (A) / Fuse / Frame size	No. of poles	Switch I - TEST	Changeover switch I - 0 - II	External front handle	TEST external front handle	External right side handle	Changeover external front handle	Shaft for external handle	Auxiliary contacts ⁽³⁾	Terminal shrouds ⁽²⁾	Integrated solid neutral link
160 A 00 13	2 P	3831 2015								2 P 3998 2016 3 P 3998 3016 4 P 3998 4016	3829 9320
	3 P	3831 3015	3870 3015								
	4 P	3831 6015	3870 6015								
160 A 0 14	2 P	3831 2016		S2 type	S2 type	S2 type	S2 type	320 mm 1400 1032		2 P 3998 2025 3 P 3998 3025 4 P 3998 4025	3829 9325
	3 P	3831 3016⁽¹⁾	3870 3016								
	4 P	3831 6016⁽¹⁾	3870 6016								
250 A 1 15	2 P	3831 2024		Red/Yellow IP65 1424 2111	Red/Yellow IP65 1424 2115	Red/Yellow IP65 1428 2111	Red/Yellow IP65 1424 2113			2 P 3998 2025 3 P 3998 3025 4 P 3998 4025	3829 9325
	3 P	3831 3024⁽¹⁾	3870 3024								
	4 P	3831 6024⁽¹⁾	3870 6024								
400 A 2 16	2 P	3831 2038						320 mm 1400 1232	U-type 1 contact NO 3999 0701	2 P 3898 2040 3 P 3898 3040 4 P 3898 4040	3829 9339
	3 P	3831 3038⁽¹⁾	3870 3039⁽⁴⁾								
	4 P	3831 6038⁽¹⁾	3870 6039⁽⁴⁾								
630 A 3 17	2 P	3811 2063		S3 type					1 contact NC 3999 0702	2 P 3898 2080 3 P 3898 3080 4 P 3898 4080	3829 9308
	3 P	3811 3063⁽¹⁾									
	4 P	3811 6063⁽¹⁾									
800 A 3 17	2 P	3811 2080		Red/Yellow IP65 1434 3111		S3 type		320 mm 1400 1232		2 P 3898 2120 3 P 3898 3120 4 P 3898 4120	3829 9312
	3 P	3811 3080									
	4 P	3811 6080									
800 A 4 18	2 P	3811 2081		S4 type						2 P 3898 2120 3 P 3898 3120 4 P 3898 4120	3829 9312
	3 P	3811 3081									
	4 P	3811 6081									
1250 A 4 18	2 P	3811 2120		Red/Yellow IP65 1444 3111						2 P 3898 2120 3 P 3898 3120 4 P 3898 4120	3829 9312
	3 P	3811 3120									
	4 P	3811 6120									

(1) Available enclosed (see "Enclosed fuse switches" page 730).

(2) Top/bottom.

(3) Maximum 4 contacts.

(4) Terminal shrouds: 3 P - 3998 3025, 4 P - 3998 4025.

FUSERBLOC

Fuse combination switches

for industrial fuses up to 1250 A

References (continued)

NFC and DIN - Direct operation - 25 to 125 A

Rating (A) Fuse size Frame size	No. of poles	Direct side operation	Direct front operation	Direct handle	Auxiliary contacts	Terminal shrouds	Cage terminals	Lock for fuse protection cover	Handle key interlocking accessories ⁽⁶⁾
CD 25 A 10 x 38 0	3 P		3631 3002	Black 3629 4012 ⁽¹⁾⁽²⁾	A-type 1 contact NO/NC 3999 0001 ⁽³⁾ A-type 2 contacts NO/NC 3999 0002 ⁽³⁾	IP2x as standard	Standard	Standard	
	3 P + switched neutral		3631 4002						
	3 P + solid neutral		3631 5002						
CD 32 A 10 x 38 0	3 P		3631 3003						
	3 P + switched neutral		3631 4003						
	3 P + solid neutral		3631 5003						
CD 32 A 14 x 51 0	3 P		3631 3004						
	3 P + switched neutral		3631 4004						
	3 P + solid neutral		3631 5004						
50 A 14 x 51 1	2 P	3615 2005	consult us	Black 3629 7900 ⁽⁵⁾⁽²⁾	A-type 1 contact NO/NC 3999 0021 ⁽³⁾ A-type 2 contacts NO/NC 3999 0022 ⁽³⁾	IP2x as standard	Standard	Standard	3629 7903
	3 P	3615 3005	consult us						
	4 P	3615 6005	consult us						
63 A 00C 2	2 P	3615 2006	consult us						
	3 P	3615 3006	consult us						
	4 P	3615 6006	consult us						
100 A 22 x 58 3	2 P	3615 2010	consult us	Black 3629 7901 ⁽⁵⁾⁽²⁾	A-type 1 contact NO/NC 3999 0021 ⁽³⁾ A-type 2 contacts NO/NC 3999 0022 ⁽³⁾	IP2x as standard	Standard	Standard	3629 7913
	3 P	3615 3010	consult us						
	4 P	3615 6010	consult us						
125 A 22 x 58 3	2 P	3615 2011	consult us						
	3 P	3615 3011	consult us						
	4 P	3615 6011	consult us						
125 A 00 3	2 P	3615 2012	consult us						
	3 P	3615 3012	consult us						
	4 P	3615 6012	consult us						

(1) Direct front operation.

(2) Standard.

(3) Maximum 2 contacts.

(4) Top or bottom.

(5) Direct right side operation.

(6) Locking using RONIS EL11AP lock (lock not included).

NFC and DIN - Direct operation - 160 to 400 A

Rating (A) Fuse size Frame size	No. of poles	Direct side operation	Direct front operation	Direct handle	Auxiliary contacts	Terminal shrouds	Cage terminals	Lock for fuse protection cover	Handle key interlocking accessories ⁽⁵⁾		
160 A 00 3	2 P	3615 2015	consult us	Black 3629 7901 ⁽⁴⁾⁽¹⁾		2 P 3998 2016 ⁽³⁾	3 P 5400 3016	3999 8912	3629 7913		
	3 P	3615 3015	consult us			3 P 3998 3016 ⁽³⁾				4 P 5400 4016	3999 8216
	4 P	3615 6015	consult us			4 P 3998 4016 ⁽³⁾					3999 8316
160 A 0 4	2 P	3615 2016	consult us	Black 3629 7901 ⁽⁴⁾⁽¹⁾	A-type 1 contact NO/NC 3999 0021 ⁽²⁾	2 P 3998 2025 ⁽³⁾	3 P 5400 3025	3999 8225			
	3 P	3615 3016	consult us			3 P 3998 3025 ⁽³⁾	4 P 5400 4025	3999 8325			
	4 P	3615 6016	consult us			4 P 3998 4025 ⁽³⁾		3999 8425			
250 A 1 5	2 P	3615 2024	consult us	Black 3629 7901 ⁽⁴⁾⁽¹⁾	A-type 2 contacts NO/NC 3999 0022 ⁽²⁾	2 P 3998 2025 ⁽³⁾	3 P 5400 3025	3999 8225			
	3 P	3615 3024	consult us			3 P 3998 3025 ⁽³⁾	4 P 5400 4025	3999 8325			
	4 P	3615 6024	consult us			4 P 3998 4025 ⁽³⁾		3999 8425			
400 A 2 6	2 P	3615 2039	consult us	Black 3629 7901 ⁽⁴⁾⁽¹⁾		2 P 3998 2025 ⁽³⁾	3 P 5400 3025	3999 8225			
	3 P	3615 3039	consult us			3 P 3998 3025 ⁽³⁾	4 P 5400 4025	3999 8325			
	4 P	3615 6039	consult us			4 P 3998 4025 ⁽³⁾		3999 8425			

(1) Standard.

(2) Maximum 2 contacts.

(3) Top/bottom.

(4) Direct right side operation.

(5) Locking using RONIS EL11AP lock (lock not included).

NFC and DIN - Direct operation - 630 to 1250 A

Rating (A) Fuse size Frame size	No. of poles	Direct side and front operation	Direct front handle	Direct side handle	Auxiliary contacts	Terminal shrouds
630 A 3 17	2 P	3811 2063	Black 3899 6011 ⁽¹⁾⁽²⁾			2 P 3898 2080 ⁽³⁾
	3 P	3811 3063				3 P 3898 3080 ⁽³⁾
	4 P	3811 6063				4 P 3898 4080 ⁽³⁾
800 A 3 17	2 P	3811 2080	Black 3899 6011 ⁽¹⁾⁽²⁾	S3 type Black 3899 7911 + 1437 3111	U-type 1 contact NO 3999 0701 ⁽⁴⁾ 1 contact NC 3999 0702 ⁽⁴⁾	4 P 3898 4080 ⁽³⁾
	3 P	3811 3080				
	4 P	3811 6080				
800 A 4 18	2 P	3811 2081	Black 3899 7011 ⁽¹⁾⁽²⁾			2 P 3898 2120 ⁽³⁾
	3 P	3811 3081				3 P 3898 3120 ⁽³⁾
	4 P	3811 6081				4 P 3898 4120 ⁽³⁾
1250 A 4 18	2 P	3811 2120	Black 3899 7011 ⁽¹⁾⁽²⁾			2 P 3898 2120 ⁽³⁾
	3 P	3811 3120				3 P 3898 3120 ⁽³⁾
	4 P	3811 6120				4 P 3898 4120 ⁽³⁾

(1) Direct front operation.

(2) Standard.

(3) Top/bottom.

(4) Maximum 8 contacts.

FUSERBLOC

Fuse combination switches

for industrial fuses up to 1250 A

Accessories

Direct operation handle

For front operation				
Rating (A)	Frame size	Figure no.	Handle colour	Reference
20 ... 32	0	1	Black	3629 4012
20 ... 32	0	1	Red	3629 4013
32 ... 400	11 ... 16	2	Black	3629 7910 (1)
630 ... 800	17	2	Black	3899 6011
800 ... 1250	18	3	Black	3899 7011

For right side operation				
Rating (A)	Frame size	Figure no.	Handle colour	Reference
32 ... 63	1/2	4	Black	3629 7900
100 ... 400	3 ... 6	4	Black	3629 7901
630 ... 1250	17 ... 18	5	Black	1437 7911

(1) Direct operation handle for switches 3841 xxxx and 3831 xxxx.



External front operation handle

Padlockable handle in position 0							
Rating (A)	Frame size	Handle type	Handle colour	Operation	External IP ⁽¹⁾	Defeatable handle	Reference
CD 25 ... 63	0/11/12	S1	Black	I - 0	IP55	Yes	1411 2111
CD 25 ... 63	0/11/12	S1	Black	I - 0	IP65	Yes	1413 2111
CD 25 ... 63	0/11/12	S1	Red/Yellow	I - 0	IP65	Yes	1414 2111
CD 25 ... 63	0/11/12	S1	Black	I - 0 - Test	IP65	Yes	1413 2115
CD 25 ... 63	0/11/12	S1	Red/Yellow	I - 0 - Test	IP65	Yes	1414 2115
100 ... 400	13 ... 16	S2	Black	I - 0	IP55	Yes	1421 2111
100 ... 400	13 ... 16	S2	Black	I - 0	IP65	Yes	1423 2111
100 ... 400	13 ... 16	S2	Red/Yellow	I - 0	IP65	Yes	1424 2111
100 ... 400	13 ... 16	S2	Black	I - 0 - Test	IP65	Yes	1423 2115
100 ... 400	13 ... 16	S2	Red/Yellow	I - 0 - Test	IP65	Yes	1424 2115
630 ... 800	17	S3	Black	I - 0	IP65	Yes	1433 3111
630 ... 800	17	S3	Red/Yellow	I - 0	IP65	Yes	1434 3111
800 ... 1250	18	S4	Black	I - 0	IP65	Yes	1443 3111
800 ... 1250	18	S4	Red/Yellow	I - 0	IP65	Yes	1444 3111

(1) IP: protection degree according to IEC 60529 standard.

Padlockable handle in position 0 and 1					
Rating (A)	Frame size	Handle type	Handle colour	External IP ⁽¹⁾	Reference
CD 25 ... 63	0/11/12	S1	Black	IP65	1413 2311
100 ... 400	13 ... 16	S2	Black	IP65	1423 2311

(1) IP: protection degree according to IEC 60529 standard.



External right side operation handle

Rating (A)	Frame size	Handle type	Handle colour	External IP ⁽¹⁾	Reference
CD 25 ... 63	0/11/12	S1	Black	IP55	1415 2111
CD 25 ... 63	0/11/12	S1	Black	IP65	1417 2111
CD 25 ... 63	0/11/12	S1	Red/Yellow	IP65	1418 2111
100 ... 400	13 ... 16	S2	Black	IP55	1425 2111
100 ... 400	13 ... 16	S2	Black	IP65	1427 2111
100 ... 400	13 ... 16	S2	Red/Yellow	IP65	1428 2111
630 ... 1250	17/18	S3	Black	IP65	1437 3111
630 ... 1250	17/18	S3	Red/Yellow	IP65	1438 3111

(1) IP: protection degree according to IEC 60529 standard.



External front operation handle with metal padlocking lever

Rating (A)	Frame size	Handle type	Handle colour	External IP ⁽¹⁾	Defeatable handle	Reference
CD 25 ... 63	0/11/12	S1	Black	IP65	Yes	141D 2911
CD 25 ... 63	0/11/12	S1	Red/Yellow	IP65	Yes	141E 2911
100 ... 400	13 ... 16	S2	Black	IP65	Yes	142D 2911
100 ... 400	13 ... 16	S2	Red/Yellow	IP65	Yes	142E 2911
600 ... 800	17	S3	Black	IP65	Yes	143D 3911
600 ... 800	17	S3	Red/Yellow	IP65	Yes	143E 3911
800 ... 1250	18	S4	Black	IP65	Yes	144D 3911
800 ... 1250	18	S4	Red/Yellow	IP65	Yes	144E 3911

(1) IP: protection degree according to IEC 60529 standard.



S2 type handle

S3 type handle

S-type handle adapter

Use

Enables S-type handles to be fitted in place of existing older style Socomec handles.

Adapter can be utilised as a spacer to increase the distance between the panel door and the handle lever.

Dimensions

Adds 12 mm to the depth of the handle.

Handle colour	To be ordered in multiples of	External IP ⁽¹⁾	Reference
Black	1	IP65	1493 0000

(1) IP: protection degree according to IEC 60529 standard.



access_187_a_1_cat

Alternative S-type handle cover colours

Use

For single lever handles S1, S2, S3 types and double lever handle, S4 type. Other colours: please consult us.

Handle colour	To be ordered in multiples of	Handle type	Reference
Light grey	50	S1, S2	1401 0001
Dark grey	50	S1, S2	1401 0011
Light grey	50	S4	1401 0031
Dark grey	50	S4	1401 0041

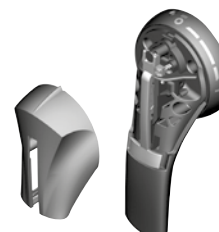

access_198_a_1_cat

Flat mounting kit

Use

The flat mounting providing compact solution ideally suited to withdrawable applications.

Kit to be used with a handle for flat mounting.

Rating (A)	Frame size	Type	Reference
CD 25 ... CD 32	0	Kit + Shaft 200 mm	1429 7709
50 ... 400	11 ... 16	Kit + Shaft 200 mm	1429 7710



fuser_535_a_1_cat

Handle for flat mounting kit

Padlockable handle in position 0						
Rating (A)	Frame size	Handle type	Handle colour	External IP ⁽¹⁾	Reference	
CD 25 ... 63	0/11/12	S1	Black	IP55	1411 2111 ⁽²⁾	
CD 25 ... 63	0/11/12	S1	Red/Yellow	IP65	1414 2111 ⁽²⁾	
100 ... 400	13 ... 16	S2	Black	IP55	1421 2111 ⁽²⁾	
100 ... 400	13 ... 16	S2	Red/Yellow	IP65	1424 2111 ⁽²⁾	

(1) IP: protection degree according to IEC 60529 standard.

(2) Defeatable handle in position I.



S2 type handle.

fuser_536_a_1_cat

FUSERBLOC

Fuse combination switches

for industrial fuses up to 1250 A

Accessories (continued)

Front operation shaft support accessory

Use

This support maintains shaft position for extension shafts greater than 320 mm in length.



fuser_698_a_2_cat

Rating (A)	Frame size	Reference
50 ... 400	11 ... 16	3899 0400

Shaft guide for external operation

Use

To guide the shaft extension into the external handle.

This accessory enables the handle to engage the extension shaft with a misalignment of up to 15 mm.

Required for a shaft lengths over 320 mm.



access_260_a_2_cat

Description	Reference
Shaft guide	1429 0000

Shaft for external front operation handle

Use

Standard lengths:

- 200 mm
- 320 mm
- 400 mm
- 500 mm.

Other lengths: consult us.

Rating (A)	Frame size	Shaft length (mm)	Reference
CD 20 ... CD 32	0	200	1401 0520
CD 20 ... CD 32	0	320	1401 0532
CD 20 ... CD 32	0	400	1401 0540 ⁽¹⁾
32 ... 400	11 ... 16	200	1400 1020
32 ... 400	11 ... 16	320	1400 1032
32 ... 400	11 ... 16	500	1400 1050 ⁽²⁾
630 ... 800	17	200	1400 1220
630 ... 1250	17/18	320	1400 1232
630 ... 1250	17/18	500	1400 1250 ⁽¹⁾

(1) Use the shaft guide accessory for external operation.

(2) Use the front operation shaft support accessory.

access_145_b_1_cat



access_369_a_1_cat

access_202_a_1_x_cat

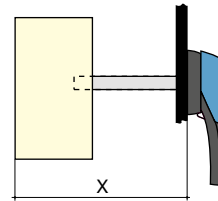

Dimension X (mm) for FUSERBLOC BS88

Rating (A)	CD 20 ... CD 32	32	63 ... 160	CD160 ... CD200	160 ... 200	250 ... 315	630 ... 800	1250
Fuse size	A1	A1	A2-A3/A4	A3-A4	B1-B2	B1-B2-B3	C1-C2-C3	D1
Frame size	0	11	12/13/14	13 A	14/15	15/16	17	18
Shaft length (mm)								
200	102 ... 245	100 ... 230	125 ... 230	150 ... 230	135 ... 230	160 ... 230	270 ... 304	
320	102 ... 365	100 ... 350	125 ... 350	150 ... 350	135 ... 350	160 ... 350	270 ... 424	304 ... 424
400	102 ... 445							
500		100 ... 530	125 ... 530	150 ... 530	135 ... 530	160 ... 530	270 ... 600	304 ... 600

Dimension X (mm) for FUSERBLOC NFC and DIN

Rating (A)	CD 25 ... CD 32	50	63	100 ... 160	160	250 ... 400	630 ... 800	800 ... 1250
Fuse size	10x38/14x51	14x51	00C	22x58/00	0	1/2	3	4
Frame size	0	11	12	13	14	15/16	17	18
Shaft length (mm)								
200	102 ... 245	100 ... 230	125 ... 230	135 ... 230	145 ... 230	160 ... 230	270 ... 304	
320	102 ... 365	100 ... 350	125 ... 350	135 ... 350	145 ... 350	160 ... 350	270 ... 424	304 ... 424
400	102 ... 445	100 ... 430	125 ... 430	135 ... 430	145 ... 430	160 ... 430	270 ... 504	304 ... 504
500		100 ... 530	125 ... 530	135 ... 530	145 ... 530	160 ... 530	270 ... 604	304 ... 604

Shaft extensions for external side operation

Use

Standard lengths, 200 mm.

Rating (A)	Frame size	Handle type	Dimension Y (mm)	Shaft length (mm)	Reference
CD 25 ... CD 32	0	S	36 ... 159	200	1401 0520
50 ... 400	11 ... 16	S	36 ... 172	200	1400 1020
630 ... 1250	17/18	S	15 ... 150	200	1400 1220

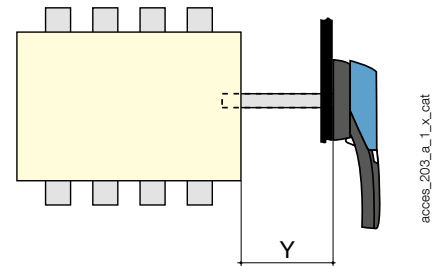

access_203_a_1_X_cat

Integrated solid neutral link

Use

Fixing the solid neutral onto the mechanism produces a device with a solid neutral of the same size as a standard three-pole device (+ 6 mm).

BS88 for external front operation			
Rating (A)	Switch body size	Bar rating (A)	Reference
32 ... 100	11/12/13	125	3829 9310
CD 160 ... CD 200	13a	200	3829 9320
160	14	200	3829 9320
200 ... 250	15	250	3829 9325
315 ... 400	16	400	3829 9339
630 ... 800	17	800	3829 9308
1250	18	1250	3829 9312

NFC and DIN For external front operation			
Rating (A)	Frame size	Bar rating (A)	Reference
50 ... 125	11/12/13	125	3829 9310
160	13	160	3829 9320
160	14	200	3829 9320
250	15	250	3829 9325
400	16	400	3829 9339
630 ... 800	17	800	3829 9308
800 ... 1250	18	1250	3829 9312



access_130_a_1_cat

access_131_a_1_cat

Solid neutral module

BS88 for external front operation				
Rating (A)	Switch body size	I _{max} (A)	Distance (mm)	Reference
32	1/11	32	27	3629 9227
63	2/12	63	32	3629 9232
100	3/13	100	36	3629 9236
CD 160 ... CD 200	13 a	200	36	3629 9237
160	4/14	160	50	3629 9250
200 ... 250	5/15	250	60	3629 9260
315 ... 400	6	400	66	3629 9266⁽¹⁾
630 ... 800	17	800	94	3629 9294
1250	18	1250	120	3629 9212

NFC and DIN For external front operation				
Rating (A)	Frame size	I _{max} (A)	Distance (mm)	Reference
50	1/11	50	27	3629 9227
63	2/12	63	32	3629 9232
100 ... 160	3/13	160	36	3629 9236
160	4/14	160	50	3629 9250
250	5/15	250	60	3629 9260
400	6/16	400	60	3629 9266⁽¹⁾
630 ... 800	17	800	94	3629 9294
800 ... 1250	18	1250	120	3629 9212

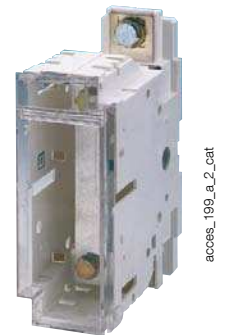

access_199_a_2_cat

(1) For external front operation switches an adaptation kit 3999 0000 must be ordered in addition to the original product reference

Solid links

BS88 switches				
Rating (A)	Frame size	Fuse size	I _{max} (A)	Reference
32	11	A1	32	3629 9003
63	12	A2-A3	63	3629 9006
100	13	A4	160	3629 9010
CD 160	13a	A3-A4	160	3629 9010
160	14	A4	160	3629 9010
160	14	B1-B2	200	3629 9016
CD 200	13a	A3-A4	160	3629 9010
200	15	B1-B2	200	3629 9016
250	15	B1-B2-B3	315	3629 9025
315	16	B1-B2-B3	315	3629 9025
400	16	B1-B2-B3-B4	400	3629 9040
630 ... 800	17	C1-C3	800	3629 9063
1250	18	D1	1250	3629 9120

NFC and DIN switches				
Rating (A)	Frame size	Fuse size	I _{max} (A)	Reference
50	1/11	14 x 51	50	6029 0000
63	2/12	00C	160	6420 0000
100 ... 125	3/13	22 x 58	125	6039 0000
125 ... 160	3/13	00	160	6420 0000
160	4/14	0	160	6421 0000
250	5/15	1	250	6421 0001
400	6/16	2	400	6421 0002
630 ... 800	17	3	800	6421 0003
800 ... 1250	18	4	1250	6441 0005

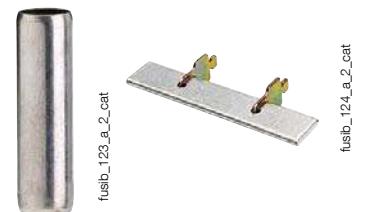

fusb_123_a_2_cat

fusb_124_a_2_cat

FUSERBLOC

Fuse combination switches

for industrial fuses up to 1250 A

Accessories (continued)

A-type auxiliary contacts

Use

Pre-break and position 0 and I signalling by 1 or 2 NO /NC auxiliary contacts. For low level use, specific auxiliary contacts: please consult us.

Connection to the control circuit

By 6.35 mm fast-on terminal.

Electrical characteristics

30 000 operations.

References

NO / NC auxiliary contacts			
Rating (A)	Frame size	Contact(s)	Reference
CD 20 ... CD 32	0	1	3999 0001
CD 20 ... CD 32	0	2	3999 0002
32 ... 400 ⁽¹⁾	1 ... 6	1	3999 0021 ⁽²⁾
32 ... 400 ⁽¹⁾	1 ... 6	2	3999 0022 ⁽²⁾

(1) Side direct operation switch only.

(2) A type auxiliary contacts cannot be mounted in conjunction with integrated solid neutral.

Characteristics

Rating (A)	Current nominal (A)	Operating current I _e (A)			
		250 VAC AC-13	400 VAC AC-13	24 VDC DC-13	48 VDC DC-13
CD 20 ... 400	16	4	2	12	2



access_046_a_1_cat

access_047_a_2_cat

U-type auxiliary contacts⁽¹⁾

Use

Compact universal type auxiliary contacts which can be configured for operation in either, or both, ON and TEST positions for CD 20 to 1250 A FUSERBLOC. Each slot can accommodate up to two interlocked A/Cs.

Connection to the control circuit

By terminals with max. section 2 x 2.5 mm².

For FUSERBLOC CD 20 to 400 A: Pre-break and signalling of positions 0, I and TEST.

For FUSERBLOC ≥ 630 A: Pre-break and position 0 and I signalling.

References

NO auxiliary contacts			
Rating (A)	Frame size	Contact(s)	Reference ⁽¹⁾
CD 20 ... 1250	0 ... 18	1	3999 0701 ⁽²⁾

NC auxiliary contacts			
Rating (A)	Frame size	Contact(s)	Reference ⁽¹⁾
CD 20 ... 1250	0 ... 18	1	3999 0702 ⁽²⁾

(1) Cannot be mounted in direct operation CD20 - CD32 switches..

(2) 4 auxiliary contacts as standard without additional A/C holder.

Contact holder for additional auxiliary contacts			
Rating (A)	Frame size	Contact(s)	Reference
CD 20 ... CD 32	0	4 (2 x 2 max)	3999 0710
32 ... 400	11 ... 16	4 (2 x 2 max)	3999 0600

Characteristics

Rating (A)	Operating current I _e (A)			
	250 VAC AC-15	400 VAC AC-15	24 VDC DC-13	48 VDC DC-13
CD 20 ... 1250	3	1.8	2.8	1.4



access_066_a_1_cat

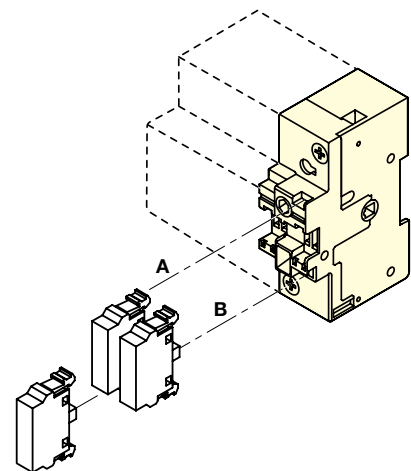

access_043_a_1_x_cat

(1) CD 20 - CD 32 : U-type auxiliary contacts cannot be mounted on switches with an integrated solid neutral or with direct operation handle.

S and ST-type auxiliary contacts

Use

For FUSERBLOCs 32 to 1250 A, position 0 and I signalling by 1 to 4 NO + NC auxiliary contacts.

Electrical principle

The NO + NC S-type auxiliary contacts can be configured as 2 NC or 2 NO.

References

S-type auxiliary contacts 0-I for external front and right-side operation (Standard operation)

Rating (A)	Frame size	Contact type	S-type AC Reference	Drive shaft (optional) Reference
32 ... 1250	11 ... 18	NC+NO	3999 0041 ⁽¹⁾	3999 0003

ST-type auxiliary contacts I-0-TEST for external front and right-side operation (TEST operation)

Rating (A)	Frame size	Contact type	Description	ST-type AC Reference	Drive shaft Reference
32 ... 400	11 ... 16	NC+NO	TEST + ON	3999 0141 ⁽²⁾	3999 0103
32 ... 400	11 ... 16	2 O	TEST + ON	3999 0241 ⁽²⁾	3999 0103

(1) Drive shaft included with S-type Auxiliary Contact.

(2) Drive shaft to be ordered in addition to the ST-type Auxiliary Contact.

Characteristics

Rating (A)	Current nominal (A)	Operating current I _o (A)	
		250 VAC AC-13	400 VAC AC-13
32 ... 1250	20	10	8

Connection

By terminals with max. cross-section 10 mm².

Mechanical characteristics

30 000 operations.



access_051_a_2_cat

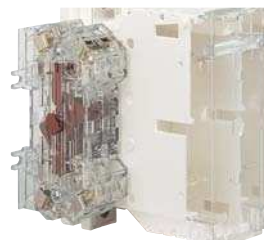

access_063_a_1_cat

Important:

- > For the 400 A frame size 16, an adaptation kit reference 3999 0000 must be ordered in addition to the auxiliary contact kit.

Fuse cover interlocking

Use

On NFC and DIN, side direct operation, locking of the opening of the fuse protection cover when FUSERBLOC is engaged (position I).

Rating (A)	Frame size	Fuse size	No. of poles	Reference
CD 20 ... 50	0 ... 1	10 x 38 / 14 x 51	2 / 3 / 4	included
63	2	00C	2 / 3 / 4	3999 8906
100 ... 125	3	22 x 58	2 / 3 / 4	3999 8912
125 ... 160	3	00	2 / 3 / 4	3999 8912
160	4	0	2 P	3999 8216
160	4	0	3 P	3999 8316
160	4	0	4 P	3999 8416
250	5	1	2 P	3999 8225
250	5	1	3 P	3999 8325
250	5	1	4 P	3999 8425
400	6	2	2 P	3999 8240
400	6	2	3 P	3999 8340
400	6	2	4 P	3999 8440

Terminal shrouds

Use

Top or bottom IP20 protection (on the front) against direct contact with terminals or connection parts.

Two sets required to fully shroud both incoming and outgoing terminals.

Rating (A)	Frame size	Position	No. of poles	Reference
CD 20 ... 63	0/1/2/12	top / bottom	2 / 3 / 4 P	integrated
100 ... CD 200	3/4/13/14	top / bottom	2 P	3998 2016
100 ... CD 200	3/4/13/14	top / bottom	3 P	3998 3016
100 ... CD 200	3/4/13/14	top / bottom	4 P	3998 4016
200 ... 400	5/6/15	top / bottom	2 P	3998 2025
200 ... 400	5/6/15	top / bottom	3 P	3998 3025
200 ... 400	5/6/15	top / bottom	4 P	3998 4025
315 ... 400	16	top / bottom	2 P	3898 2040
315 ... 400	16	top / bottom	3 P	3898 3040
315 ... 400	16	top / bottom	4 P	3898 4040
630 ... 800	17	top / bottom	2 P	3898 2080
630 ... 800	17	top / bottom	3 P	3898 3080
630 ... 800	17	top / bottom	4 P	3898 4080
800 ... 1250	18	top / bottom	2 P	3898 2120
800 ... 1250	18	top / bottom	3 P	3898 3120
800 ... 1250	18	top / bottom	4 P	3898 4120



fuser_314_a_1_cat

FUSERBLOC

Fuse combination switches

for industrial fuses up to 1250 A

Accessories (continued)

NFC and DIN worked fuse indication

Use

For fuse cartridge with striker (size 14 x 51 22 x 58; 0; 1; 2; 3 and 4).

Electrical principle

A NO/NC auxiliary contact detects that the fuse has blown.

References

NO/NC type auxiliary contacts for 2 pole

Rating (A)	Frame size	Fuses	Contact(s)	Reference
50	11	14 x 51	1 st	3994 0405
100 ... 125	13	22 x 58	1 st	3994 0210
160	14	0	1 st	3994 0216
250	15/16	1-2	1 st	3994 0225
400 ⁽¹⁾	16	2	1 st	3894 0440
630	17	3	1 st	3894 1206
800 ... 1250	18	4	1 st	3894 1212

NO/NC type auxiliary contacts for 3 pole

Rating (A)	Frame size	Fuses	Contact(s)	Reference
CD 32	0	14 x 51	1 st	3994 0303
50	11	14 x 51	1 st	3994 0405
100 ... 125	13	22 x 58	1 st	3994 0310
160	14	0	1 st	3994 0316
250	15/16	1-2	1 st	3994 0325
400 ⁽¹⁾	16	2	1 st	3894 0440
630	17	3	1 st	3894 1306
800 ... 1250	18	4	1 st	3894 1312
50 ... 250	11	-	2 nd	3994 1901
400	16	2	2 nd	3994 1902
630 ... 1250	16	-	2	3994 1901

NO/NC type auxiliary contacts for 4 pole or 3 pole + neutral

Rating (A)	Frame size	Fuses	Contact(s)	Reference
50	11	14 x 51	1 st	3994 0405
100 ... 125	13	22 x 58	1 st	3994 0410
160	14	0	1 st	3994 0416
250	15/16	1-2	1 st	3994 0425
400 ⁽¹⁾	16	2	1 st	3894 0440
630	17	3	1 st	3894 1406
800 ... 1250	18	4	1 st	3894 1412
50 ... 250	11	-	2 nd	3994 1901
400	16	2	2 nd	3994 1902
630 ... 1250	16	-	2	3994 1901

(1) For front direct and external left side operation handles, please order references 39940225 (2P), 39940325 (3P), 39940425 (4P)

Characteristics

Rating (A)	Current nominal (A)	Operating current I _n (A)			
		250 VAC AC-13	400 VAC AC-13	24 VDC DC-13	48 VDC DC-13
CD 32 ... 1250	16	4	3	12	2

Connection to the control circuit

6.35 mm fast-on terminal.

Mechanical characteristics

30 000 operations.



DDMM for cylindrical fuses



DDMM for NH fuses

fuser_311_a_1_cat

fuser_312_a_1_cat

Electronic fuse monitoring device (FMD)

Use

Provides fuse state monitoring and worked fuse indication even for fuse links without monitoring device strikers. Suitable for use with BS88, DIN and UL type fuses.

Principle

The Fuse Monitoring Device (FMD) detects the worked fuse and provides a signal via: a relay and 1 LED (FMD10) or a bi-stable relay and 3 LEDs (FMD30).

The FMD can be DIN rail or back plate mounted close to the Fuserbloc, directly mounted on the FUSERBLOC, or it can be door mounted to provide information directly on the front of a panel.

References

For FUSERBLOC 63 to 1250A - size 000 to 4

Nb of LEDs	Operating voltage Ph/Ph	Reference
1 (FMD10)	120 - 260 VAC	3899 1120
1 (FMD10)	380 - 690 VAC	3899 1380
3 (FMD30)	120 - 260 VAC	3899 3120
3 (FMD30)	380 - 690 VAC	3899 3380

Accessories

Accessories	Reference
Kit for connection accessories	Standard 3819 9120
Kit for connection accessories	Door mounted 3829 9120

Relay characteristics

Rating (A)	Relay operating current I _n (A)	
	AC-15	DC-13
63 ... 1250	2.5 A	0.2



1 LED version (FMD10)

3 LED version (FMD30)

access_319_a

access_310_a

Important:

- > For direct mounting on the 400 A frame size 16, an adaptation kit reference 3999 0000 must be ordered in addition to the FMD.

Cage terminals

Use

Connection of bare copper cables onto the terminals (without lugs).

References

Rating max (A)	Frame size	No. of poles	Reference
CD 20 ... 63	0 ... 12	2 / 3 / 4 P	integrated
100 ... 160	13/14	3 P	5400 3016
100 ... 160	13/14	4 P	5400 4016
250	15	3 P	5400 3025
250	15	4 P	5400 4025
400	16	3 P	5400 3040
400	16	4 P	5400 4040



access_053_a_1_cat

Connections

Rating (A)	Flexible cable cross-section (mm ²)	Rigid cable cross-section (mm ²)	Flexible bar width (mm)	Stripped over (mm)
100 ... 160	16 ... 95	16 ... 95	13	22
250	16 ... 185	16 ... 185	18	27
400	50 ... 240	50 ... 300	20	34

Dimensions

Rating (A)	A	A1	C	R	ØX	X1	Z
100 ... 160	47.5	22.5	25	20	8.5	M12	10
250	62	31.5	31.5	25	10.5	M16	14
400	71.5	32	38	32	10.5	M20	15

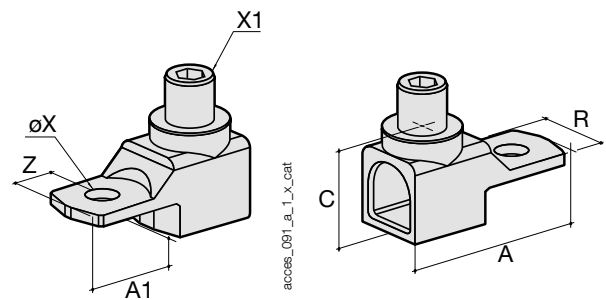

access_091_a_1_x_cat

access_092_a_1_x_cat

Handle key interlocking accessories

Use

Locking in position 0 of the direct, front or right side operation:

- using a padlock (not supplied) in direct right side operation: integrated into the handle,

- using a padlock (not supplied): right-side or front operation switch from 32 to 1250 A, factory integrated

- using a padlock (not supplied) in external operation.

Locking using RONIS EL 11 AP lock (not supplied)

Rating (A)	Frame size	Operation	Figure n°	Reference
CD 20 ... 1250	0 ... 18	external front	2	1499 7701
32 ... 63	1/2	direct	1	3629 7903
100 ... 400	3 ... 6	direct	1	3629 7913
630 ... 1250	17 ... 18	direct		3829 7923

Locking using K-type CASTELL lock (not supplied)

Rating (A)	Frame size	Operation	Figure n°	Reference
CD 20 ... 1250	0 ... 18	external front	3	1499 7702

Locking using FS-type CASTELL lock (not supplied)

Rating (A)	Frame size	Operation	Figure n°	Reference
CD 20 ... 1250	0 ... 18	external front	3	1499 7703

Locking using XOP (not supplied)

Rating (A)	Frame size	Operation	Reference
CD 20 ... 1250	0 18	external front	1499 7702

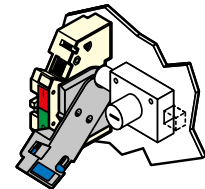

Fig. 1

access_042_a_1_x_cat

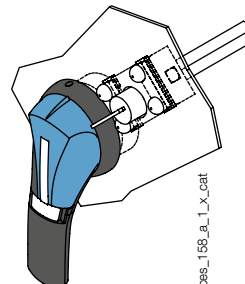

Fig. 2

access_156_a_1_x_cat

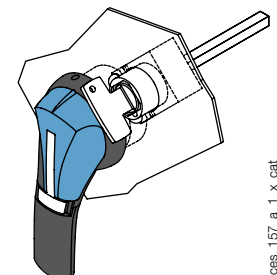

Fig. 3

access_157_a_1_x_cat

Label holder

Use

Recognisable self-adhesive label allowing identification of the devices.

Dimensions W x H (mm)	Nb of pieces in KIT	Reference
18 x 13	5	7769 9999



access_044_a_1_cat

FUSERBLOC

Fuse combination switches

for industrial fuses up to 1250 A

Characteristics according to IEC 60947-3

20 to 100 A

Thermal current I_{th} (40°C)	20 A	25 A	CD 32 A	CD 32 A	32 A	50 A	63 A	100 A
BS88/DIN fuse size	A1/-	-/10 x 38	-/10 x 38	A1/14 x 51	A1/-	-/14 x 51	A2-A3/00C	A4*/22 x 58
Frame size for direct operation	0	0	0	0	1	1	2	3
Switch body size for front and side operation	0	0	0	0	11	11	12	13
Rated insulation voltage U_i (V)	800	800	800	800	800	800	800	800
Rated impulse withstand voltage U_{imp} (kV)	8	8	8	8	8	8	8	8
Rated operational currents I_e (A)								
Rated voltage	Utilisation category	A/B ⁽¹⁾	A/B ⁽¹⁾	A/B ⁽¹⁾	A/B ⁽¹⁾	A/B ⁽¹⁾	A/B ⁽¹⁾	A/B ⁽¹⁾
400 VAC	AC-22 A / AC-22 B	20/20	25/25	32/32	32/32	32/32	50/50	63/63
400 VAC	AC-23 A / AC-23 B	20/20	25/25	32/32	32/32	32/32	50/50	63/63
690 VAC	AC-22 A / AC-22 B	20/20	25/25	32/32	32/32	32/32	50/50	63/63
690 VAC	AC-23 A / AC-23 B	20/20	25/25	32/32	32/32	32/32	50/50	63/63
220 VDC	DC-20 A / DC-20 B			-/32		32/32	50/50	63/63
220 VDC	DC-21 A / DC-21 B		-/25 ⁽⁴⁾			32/32	40/40	40/40
440 VDC	DC-20 A / DC-20 B					32 ⁽³⁾ /32 ⁽³⁾	50 ⁽³⁾ /50 ⁽³⁾	63 ⁽³⁾ /63 ⁽³⁾
440 VDC	DC-21 A / DC-21 B					32 ⁽³⁾ /32 ⁽³⁾	40 ⁽³⁾ /40 ⁽³⁾	40 ⁽³⁾ /40 ⁽³⁾
Operational power in AC-23 (kW)								
At 400 VAC without pre-break in AC ⁽¹⁾⁽⁵⁾		9/9	11/11	15/15	15/15	15/15	25/25	30/30
At 690 VAC without pre-break in AC ⁽¹⁾⁽⁵⁾		15/15	22/22	25/25	25/25	25/25	45/45	55/55
Reactive power (kvar)								
At 400 VAC ⁽⁵⁾		8	11	15	15	15	23	28
Fuse protected short-circuit withstand BS88/DIN (kA rms prospective)								
Prospective short-circuit (kA rms) ⁽⁶⁾		80/-	-/100	-/100	80/100	80/100	-/100	80/100
Associated fuse rating (A) ⁽⁶⁾		20/-	-/25	-/32	32/32	32/32	-/50	63/63
Short-circuit capacity								
Rated peak withstand current (kA peak) ⁽⁶⁾		5.5	5.5	5.5	5.5	9	7.6	10.6
Fuse selection (maximum fuse size)**								
SOCOMECS BS88 - Standard max	6A10 0020	6012 0025	6012 0032	6A10 0032	6A10 0032		6A30 0063	6A40 0100
SOCOMECS BS88 - Motor max	6A1M 0032	6013 0025	6013 0032	6A1M 0063	6A1M 0032		6A3M 0080	6A4M 0125
SOCOMECS DIN - Distribution (gl - gG)						6022 0050	6600 0063	6032 0100
SOCOMECS DIN - Motor (aM)						6023 0050	6601 0063	6033 0100
BUSSMANN - Standard max	NITD 20			NITD 32	NITD 32		BAO 63	CEO 100
BUSSMANN - Motor max	NITD 20M32			NITD 32M63	NITD 32M63		BAO 63M80	CEO 100M125
LAWSON - Standard max	NIT 20			NIT 32	NIT 32		TIS 63	TCP 100
LAWSON - Motor max	NIT 20M32				NIT 20M32		TIS 63M80	CTFP 100M125
GE - Standard max	NIT 20			NET 32	NET 32		TIS 63	TCP 100
GE - Motor max	NIT 20M32			NET 32M63	NET 32M63		TIS 63M80	OCP 100M125
Connection								
Minimum Cu cable cross-section (mm ²)	2.5	2.5	2.5	2.5	6	6	10	25
Maximum Cu cable cross-section (mm ²)	16	16	16	16	25	25	25	95
Maximum busbar width (mm)								20
Min. / Max. tightening torque min (Nm)	2/-	2/-	2/3	2	2.5/3	2.5/3	2.5/3	8.3/13
Mechanical characteristics								
Durability (number of operating cycles)	20 000	20 000	20 000	20 000	10 000	10 000	10 000	10 000
Weight of 3 P switch (kg)	0.48	0.48	0.48	0.50	0.80	0.80	1	1.5
Weight of 4 P switch (kg)	0.50	0.50	0.50	0.52	1	1	1.3	2
Weight of 1 P extra (kg)					0.2	0.2	0.3	0.5
Frame pitch (mm)					32	27	32	36

(1) Category with index A = frequent operation - Category with index B = infrequent operation.

(2) With terminal shrouds or terminal screen.

(3) 4-pole device with 2 pole in series by polarity.

(4) 3-pole device with 2 poles "+" in series and 1 pole "-".

(5) The power value is given for information only, the current values vary from one manufacturer to another.

(6) For a rated operational voltage $U_o = 400$ VAC.

* For fuse size A4: max diameter 31 mm.

** Please ensure that fuse let through current does not exceed short-circuit capacity of the switch (kA peak).

125 to 200 A

Thermal current I_{th} (40°C)	125 A	125 A	160 A	CD 160 A	160 A	160 A	CD 200 A	200 A
NFC/DIN fuse size	-/22 x 58	-/00	-/00	A3-A4*/-	A4/0	B1-B2/-	A3-A4*/-	B1-B2/-
Frame size for direct operation	3	3	3		4	4		5
Switch body size for front and side operation	13	13	13	13	14	14	13	15
Rated insulation voltage U_i (V)	800	800	800	800	800	800	800	800
Rated impulse withstand voltage U_{imp} (kV)	8	8	8	8	8	8	8	8

Rated operational currents I_e (A)

Rated voltage	Utilisation category	A/B ⁽¹⁾	A/B ⁽¹⁾	A/B ⁽¹⁾	A/B ⁽¹⁾	A/B ⁽¹⁾	A/B ⁽¹⁾	A/B ⁽¹⁾	A/B ⁽¹⁾
400 VAC	AC-22 A / AC-22 B	125/125	125/125	160/160	160/160	160/160	160/160	200/200	200/200
400 VAC	AC-23 A / AC-23 B	125/125	125/125	160/160	160/160	160/160	160/160	200/200	200/200
690 VAC	AC-22 A / AC-22 B	125 ⁽²⁾ /125 ⁽²⁾	125 ⁽²⁾ /125 ⁽²⁾	160 ⁽²⁾ /160 ⁽²⁾	160 ⁽²⁾ /160 ⁽²⁾	160 ⁽²⁾ /160 ⁽²⁾	160 ⁽²⁾ /160 ⁽²⁾	160 ⁽²⁾ /160 ⁽²⁾	200 ⁽²⁾ /200 ⁽²⁾
690 VAC	AC-23 A / AC-23 B	100 ⁽²⁾ /100 ⁽²⁾	100 ⁽²⁾ /100 ⁽²⁾	125 ⁽²⁾ /125 ⁽²⁾	125 ⁽²⁾ /125 ⁽²⁾	125 ⁽²⁾ /125 ⁽²⁾	125 ⁽²⁾ /125 ⁽²⁾	125 ⁽²⁾ /125 ⁽²⁾	160 ⁽²⁾ /200 ⁽³⁾
220 VDC	DC-20 A / DC-20 B	125/125	125/125	160/160	160/160	160/160	160/160	160/160	200/200
220 VDC	DC-21 A / DC-21 B	100/100	100/100	125/125	125/125	125/125	125/125	125/125	200/200
440 VDC	DC-22 A / DC-22 B	125 ⁽³⁾ /125 ⁽³⁾	125 ⁽³⁾ /125 ⁽³⁾	160 ⁽³⁾ /160 ⁽³⁾	160 ⁽³⁾ /160 ⁽³⁾	160 ⁽³⁾ /160 ⁽³⁾	160 ⁽³⁾ /160 ⁽³⁾	160 ⁽³⁾ /160 ⁽³⁾	200 ⁽³⁾ /200 ⁽³⁾
440 VDC	DC-23 A / DC-23 B	100 ⁽³⁾ /100 ⁽³⁾	100 ⁽³⁾ /100 ⁽³⁾	125 ⁽³⁾ /125 ⁽³⁾	160 ⁽³⁾ /160 ⁽³⁾	125 ⁽³⁾ /125 ⁽³⁾	125 ⁽³⁾ /125 ⁽³⁾	125 ⁽³⁾ /125 ⁽³⁾	200 ⁽³⁾ /200 ⁽³⁾

Operational power in AC-23 (kW)

At 400 VAC without pre-break in AC ⁽¹⁾⁽⁴⁾	63/63	63/63	80/80	80/80	80/80	80/80	80/80	100/100
At 690 VAC without pre-break in AC ⁽¹⁾⁽⁴⁾	90/90	90/90	110/110	110/110	110/110	110/110	110/110	150/185

Reactive power (kvar)

At 400 VAC ⁽⁴⁾	55	55	75	70	75	75	90	90
---------------------------	----	----	----	----	----	----	----	----

Fuse protected short-circuit withstand (kA rms prospective)

Prospective short-circuit (kA rms) ⁽⁵⁾	-/100	-/100	-/100 (50)	50/-	80/100	80/100	50/-	80/-
Associated fuse rating (A) ⁽⁵⁾	-/125	-/125	-/125 (160)	160/-	160/160	160/160	200/-	200/-

Short-circuit capacity

Rated peak withstand current (kA peak) ⁽⁵⁾	20	20	20	20	22.7	22.7	20	32.5
---	----	----	----	----	------	------	----	------

Fuse selection (maximum fuse size)**

SOCOMECS BS88 - Standard max				6A40 0160	6A40 0160	6B20 0160	6A40 0200	6B20 0200
SOCOMECS BS88 - Motor max				6A4M 0160	6A4M 0160	6B1M 0200	6A4M 0315	6B2M 0315
SOCOMECS DIN - Distribution (gl - gG)	6032 0125	6692 0125	6692 0160		6702 0160			
SOCOMECS DIN - Motor (aM)	6033 0125	6693 0125	6693 0160		6703 0160			
BUSSMANN - Standard max				DEO 160	DEO 160	DD 160	DEO 200	DD 200
BUSSMANN - Motor max				CEO 100M160	DEO 100M200	CD 100M200	DEO 200M315	DD 200M315
LAWSON - Standard max				CTFP 160	TFP 160	TF 160	TF 200	TF 200
LAWSON - Motor max				CTCP 100M160	TCP 100M200	TCP 100M200	TC 200M315	TC 200M315
GE - Standard max				TCP 100	TFP 160	TF 160	TF 200	TF 200
GE - Motor max				OCF 100M160	TCP 100M201	TC 100M200	TF 200M315	TF 200M315

Connection

Minimum Cu cable cross-section (mm ²)	35	35	35	35	50	50	35	95
Maximum Cu cable cross-section (mm ²)	95	95	95	95	95	95	95	240
Maximum busbar width (mm)	20	20	20	20	20	20	20	32
Tightening torque min (Nm)	8.3/13	8.3/13	8.3/13	8.3/13	8.3/13	8.3/13	8.3/13	20/26

Mechanical characteristics

Durability (number of operating cycles)	10 000	10 000	10 000	10 000	10 000	10 000	10 000	10 000
Weight of 3 P switch (kg)	1.5	1.5	1.8	1.8	1.8	1.8	1.8	3.2
Weight of 4 P switch (kg)	2	2	2.3	2.3	2.3	2.3	2.3	4.5
Weight of 1 P extra (kg)	0.5	0.5	0.5	0.5	0.5	0.5	0.5	1.3
Frame pitch (mm)	36	36	36	36	50	50	36	60

(1) Category with index A = frequent operation - Category with index B = infrequent operation.

(2) With terminal shrouds or phase barrier.

(3) 4-pole device with 2 poles in series per polarity.

(4) The power value is given for information only, the current values vary from one manufacturer to another.

(5) For a rated operational voltage $U_n = 400$ VAC.

** Please ensure that fuse let through current does not exceed short-circuit capacity of the switch (kA peak).

FUSERBLOC

Fuse combination switches

for industrial fuses up to 1250 A

Characteristics according to IEC 60947-3 (continued)

250 to 1250 A

Thermal current I_{th} (40°C)	250 A	315 A	400 A	630 A	800 A	800 A	1250 A
NFC/DIN fuse size	B1-B2-B3/1	B1-B2-B3/-	B1-B2-B3-B4/2	C1-C2/3	C1-C2-C3/3	-/4	D1/4
Frame size for direct operation	5	6	6	17	17	18	18
Switch body size for front and side operation	15	16	16	17	17	18	18
Rated insulation voltage U_i (V)	800	1000(800*)	1000(800*)	1000	1000	1000	1000
Rated impulse withstand voltage U_{imp} (kV)	8	12(8*)	12(8*)	12	12	12	12

Rated operational currents I_e (A)

Rated voltage	Utilisation category	A/B ⁽¹⁾	A/B ⁽¹⁾	A/B ⁽¹⁾	A/B ⁽¹⁾	A/B ⁽¹⁾	A/B ⁽¹⁾	A/B ⁽¹⁾
400 VAC	AC-22 A / AC-22 B	250/250	315/315	400/400	630/630	800/800	800/800	1250/1250
400 VAC	AC-23 A / AC-23 B	250/250	315/315	400/400	630/630	800/800	800/800	1000/1250
690 VAC	AC-22 A / AC-22 B	250 ⁽²⁾ /250 ⁽²⁾	315 ⁽²⁾ /315 ⁽²⁾	400/400	500/630	800/800	800/800	800/1250
690 VAC	AC-23 A / AC-23 B	250 ⁽²⁾ /250 ⁽²⁾	315 ⁽²⁾ /315 ⁽²⁾	315/400	315/400	630/630	800/800	800/1250
220 VDC	DC-20 A / DC-20 B	250/250	315/315	400/400	630/630	800/800	800/800	1250/1250
220 VDC	DC-21 A / DC-21 B	200/200	315/315	315/315	630/630	800/800	800/800	1250/1250
440 VDC	DC-22 A / DC-22 B	250 ⁽³⁾ /250 ⁽³⁾	315 ⁽³⁾ /315 ⁽³⁾	315 ⁽³⁾ /315 ⁽³⁾	400 ⁽³⁾ /630 ⁽³⁾	800 ⁽³⁾ /800 ⁽³⁾	800/800	1250 ⁽³⁾ /1250 ⁽³⁾
440 VDC	DC-23 A / DC-23 B	200 ⁽³⁾ /200 ⁽³⁾	250 ⁽³⁾ /315 ⁽³⁾	250 ⁽³⁾ /315 ⁽³⁾	400 ⁽³⁾ /630 ⁽³⁾	800 ⁽³⁾ /800 ⁽³⁾	800/800 ⁽³⁾	1000 ⁽³⁾ /1000 ⁽³⁾

Operational power in AC-23 (kW)

At 400 VAC without pre-break in AC ⁽¹⁾⁽⁴⁾	132/132	160/160	220/220	355/355	450/450	450/450	560/560
At 690 VAC without pre-break in AC ⁽¹⁾⁽⁴⁾	220/220	220/295	220/295	295/400	400/400	400/400	400/475

Reactive power (kvar)

At 400 VAC ⁽⁴⁾	115	145	185	290	365	355	460
---------------------------	-----	-----	-----	-----	-----	-----	-----

Fuse protected short-circuit withstand (kA rms prospective)

Prospective short-circuit (kA rms) ⁽⁵⁾	80/100	80/-	80/50	80/100	80/100	-/100	-/100
Associated fuse rating (A) ⁽⁵⁾	250/250	315/-	400/400	630/630	800/800	-/800	-/1250

Short-circuit capacity

Rated peak withstand current (kA peak) ⁽⁵⁾	32.5	40	40	70	80	80	90
---	------	----	----	----	----	----	----

Fuse selection (maximum fuse size)**

SOCOMECS BS88	6B20 0250	6B30 0315	6B40 0400	6C20 0630	6C30 0800		
SOCOMECS BS88	6B2M 3015	6B3M 0400	6B4M 0500				
SOCOMECS DIN	6712 0250		6722 0400	6732 0400		6746 0800	6746 1200
SOCOMECS DIN	6713 0250		6723 0400	6733 0400		6747 0800	6747 1200
BUSSMANN	ED 250	ED 315	ED 400	FF 630	GF 800		
BUSSMANN	DD 200M315	ED 315M400	ED 400M500				
LAWSON	TKF 250	TKF 315	TMF 400	TTM 630	TLM 800		
LAWSON	TF 200M315	TKF 315M400	TMF 400M500				
GE	TKF 250	TKF 315	TMF 400	TTM 630	TLM 800		
GE	TF 200M315	TKF 315M355	TMF 400M450				

Connection

Minimum Cu cable cross-section (mm ²)	95	185	185	2 x 150	2 x 185		
Maximum Cu cable cross-section (mm ²)	240	240	240	2 x 300	2 x 300	4 x 185	4 x 185
Maximum busbar width (mm)	32	45	45	63	63	80	80
Tightening torque min (Nm)	20/26	20/26	20/26	40/45	40/45	40/45	40/45

Mechanical characteristics

Durability (number of operating cycles)	10 000	10 000	10 000	8 000	8 000	5 000	5 000
Weight of 3 P switch (kg)	3.2	4.8	4.8	16	17	25	25
Weight of 4 P switch (kg)	4.5	6.1	6.1	20	21.5	30	30
Weight of 1 P extra (kg)	1.3	1.3	1.3			3	3
Frame pitch (mm)	60	66	66	94	94	120	120

(1) Category with index A = frequent operation - Category with index B = infrequent operation.

(2) With terminal shrouds or terminal screen.

(3) 4-pole device with 2 pole in series by polarity.

(4) The power value is given for information only, the current values vary from one manufacturer to another.

(5) For a rated operational voltage $U_e = 400$ VAC.

* Direct operation switch.

** Please ensure that fuse let through current does not exceed short-circuit capacity of the switch (kA peak).

Dimensions

External operation

NFC and DIN CD 25 to CD 32 A in size 10 x 38

External front operation

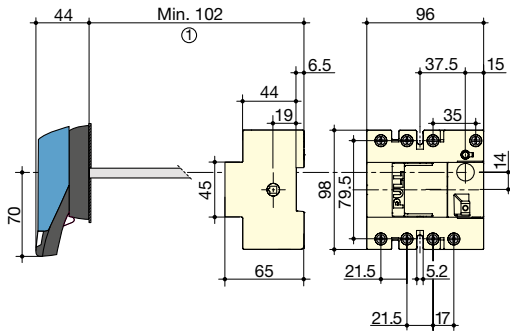

1. With 1 U-type AC: 130 mm.
 With 2 U-type AC: 155 mm.

External side operation

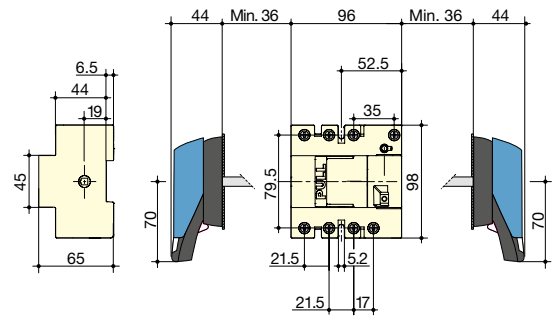

BS88 CD 20 to CD 32 A in size A1 - NFC and DIN 32 A in size 14 x 51

External front operation

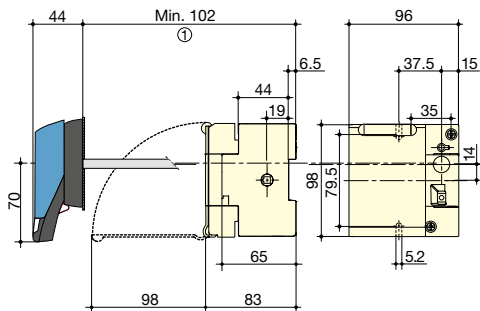

1. With 1 U-type AC: 130 mm.
 With 2 U-type AC: 155 mm.

External side operation

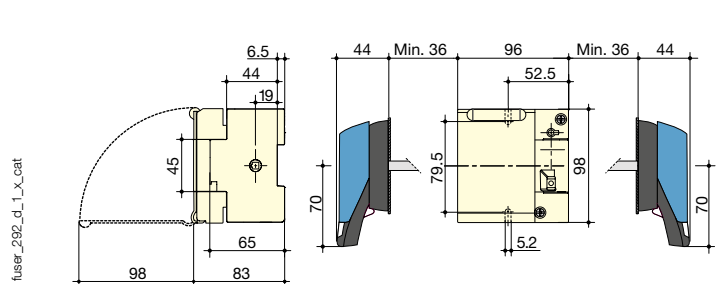

BS88 CD 20 to CD 32 A in size A1 - NFC and DIN 25 to 32 in size 10 x 38 and 14 x 51

External front operation fuse combination changeover

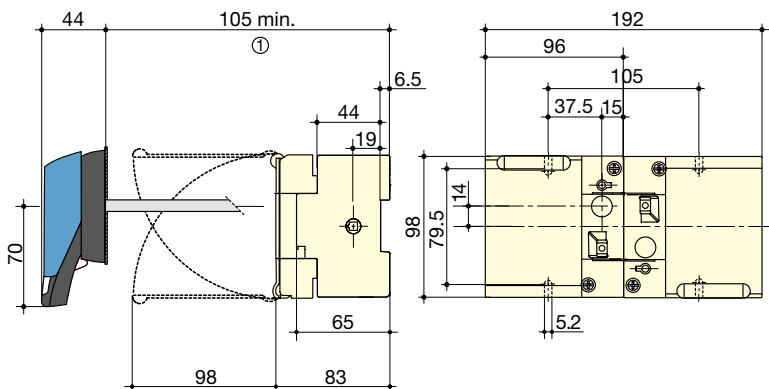

1. With 1 U-type AC: 130 mm
 With 2 U-type AC: 155 mm.

FUSERBLOC

Fuse combination switches

for industrial fuses up to 1250 A

Dimensions (continued)

External operation

BS88 32 to 250 A - NFC and DIN 50 to 250 A

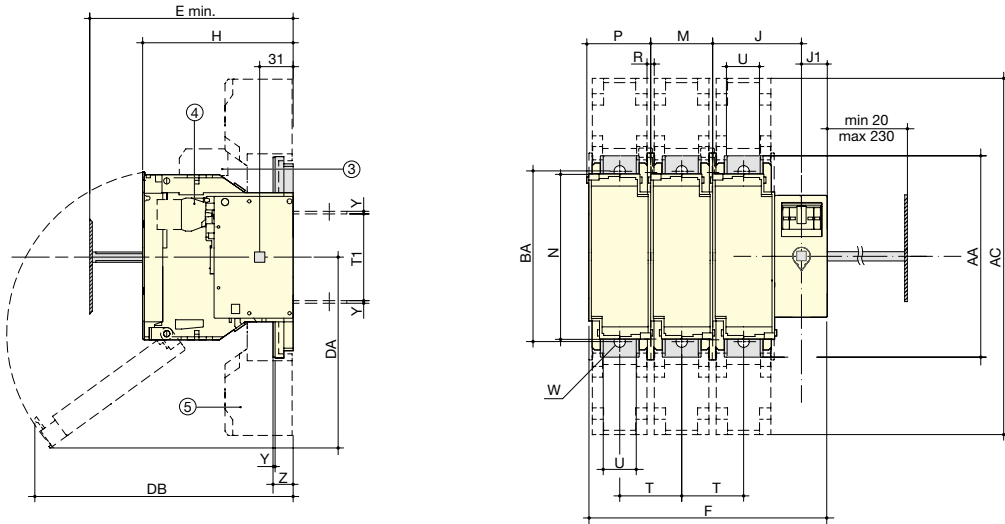

1. Position TEST.
2. Rear connection (option)
3. 1 or 2 CA type DDMM
4. 1 or 8 CA NO/NC pre-break.
5. Terminal shrouds.

Rating (A)	NFC/DIN Fuse size	BS88 Fuse size	Frame size	Overall dimensions E min	Terminal shrouds AC	Switch body								Switch mounting					Connection						
						F 3p.	F 4p.	H	J	J1	BC	DA	DB	M	N	P	R	T	T1	U	W	Y	Z	AA	BA
32		A1	11	100	-	121	148	87	45	18	70	85	153	27	106	31	6	27	59	12	-	2	-	118	-
50	14 x 51	-	11	100	-	121	148	87	45	18	70	85	153	27	106	31	6	27	59	12	-	2	-	118	-
63	00C	A2-A3	12	125	-	136	168	116	50	18	70	159	145	32	106	36	5.4	32	59	12	-	2	-	118	-
100 125	22x58	A4	13	135	268	148	184	116	54	18	125	141	179	36	127	40	5.4	36	62	20	8.5	2.5	19.5	162	141
125 160	00	-	13	135	268	148	184	126	54	18	125	141	189	36	127	40	5.4	36	62	20	8.5	2.5	19.5	162	141
CD 160 CD 200	-	A3-A4	13A	145	268	148	184	139	54	18	125	141	-	36	130	40	5.4	36	78	18	8.5	3	20	162	141
160	0	A4-B1-B2	14	145	268	190	240	136	64	18	125	174	229	50	140	54	5.4	50	62	20	8.5	2.5	19.5	162	141
200	-	B1-B2	15	154	345	234	294	146	86	25	125	185	251	60	162	64	6.4	60	84	32	11	2.5	19.5	195	166
250	1	B1-B2-B3	15	154	345	234	294	146	86	25	125	185	251	60	162	64	6.4	60	84	32	11	2.5	19.5	195	166

BS88 315 to 400 A (size B1-B2-B3-B4) - DIN 400 A (size 2)

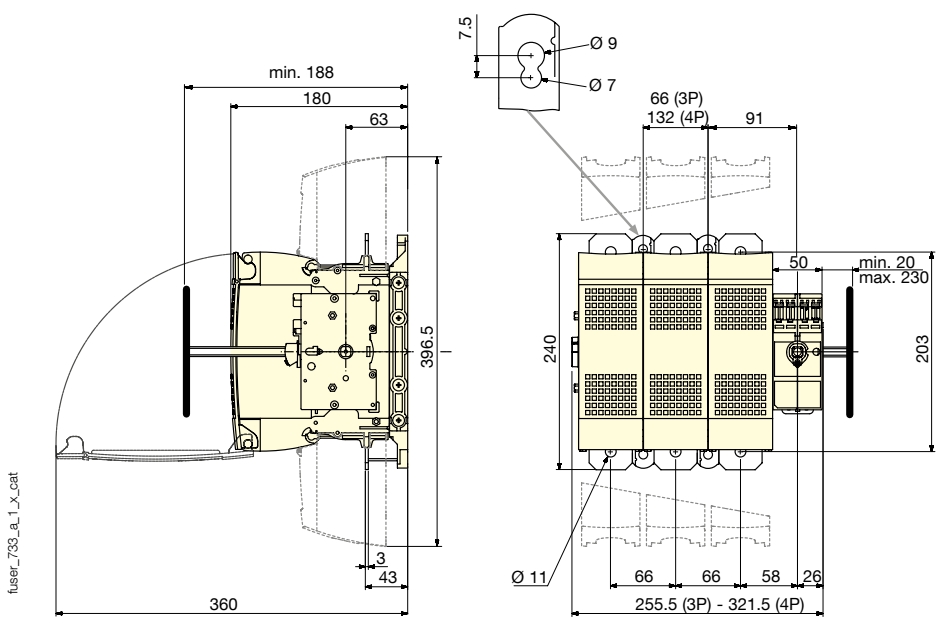

BS88 - External front operation fuse combination changeover

32 to 400 A

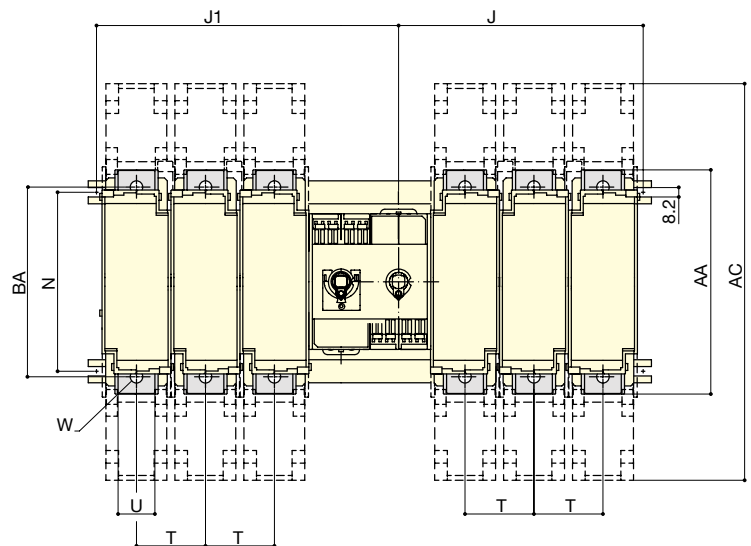
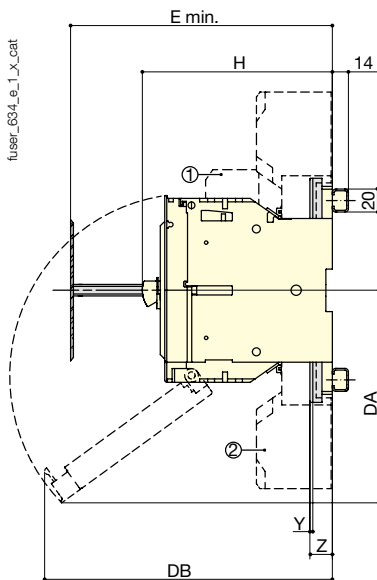
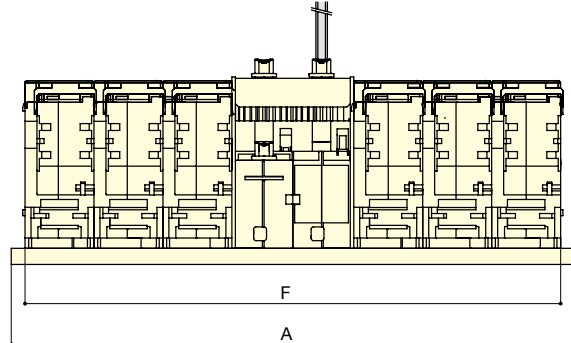

A. S1 handle: 32 and 63 A
B. S1 handle: 100 to 400 A
C. Door drilling

1. Fuse blown indication not available for BS88
2. Terminal shrouds

Rating (A)	Fuse size	Frame size	Dimensions				Terminal shrouds	Switch body								Switch mounting		Connection								
			A3 P	A4 P	E min	E max		F3 P	F4 P	H	J3 P	J4 P	J1 3P	J1 4P	DA	DB	N	T	U	W	Y	Z	AA	BA		
32	A1	11	264	318	100 ⁽¹⁾	146 ⁽¹⁾		242	296	87	102	129	138	165	85	153	90	27							118	
63	A2-A3	12	294	358	124	145		272	336	116.5	121	153	157	189	159	145	90	32							118	
100	A4	13	318	390	124	145	268	296	368	116 ⁽²⁾	133	169	169	205	141	179	128	36	20	8.5	2.5	19.5	162	141		
CD 160	A3-A4	13 A	318	390	145	225	268	296	368	139	133	169	169	205			128	36	18	8.5	3	20	162	141		
160	A4	14	402	502	124	225	268	380	480	136.5	176	226	212	262	174	229	128	50	20	8.5	2.5	19.5	162	141		
160	B1-B2	14	402	502	130	225	268	380	480	136.5	176	226	212	262	174	229	128	50	20	8.5	2.5	19.5	162	141		
CD 200	A3-A4	13 A	318	390	145	225	268	296	368	139	133	169	169	205			128	36	18	8.5	3	20	162	141		
200	B1-B2	15	490	610	130	225	345	468	588	146	213	273	263	323	185	251	155	60	32	11	2.5	19.5	195	166		
250	B1-B2-B3	15	490	610	154	225	345	468	588	146	213	273	263	323	185	251	155	60	32	11	2.5	19.5	195	166		
315	B1-B2-B3	16	526	658	154	225	355	504	636	149	231	297	281	347	200	260	168	66	50	11	3	20	205	175		
400	B1-B2-B3-B4	16	526	658	157	225	355	504	636	149	231	297	281	347	200	260	168	66	50	11	3	20	205	175		

(1) 1 AC: + 23.5 mm / 2 AC: + 47 mm.
(2) 132 mm with 2 AC.

FUSERBLOC

Fuse combination switches

for industrial fuses up to 1250 A

Dimensions (continued)

NFC and DIN - External front operation fuse combination changeover

50 to 400 A

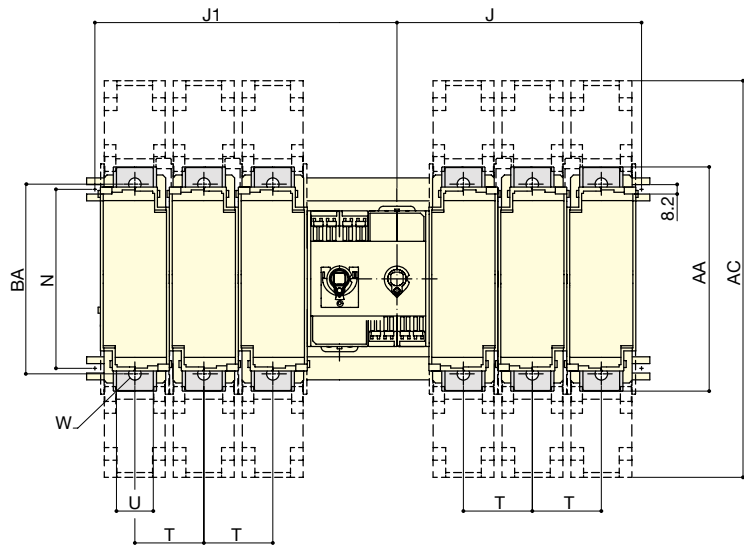
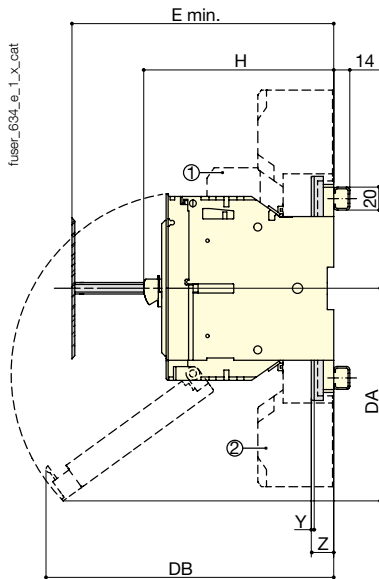
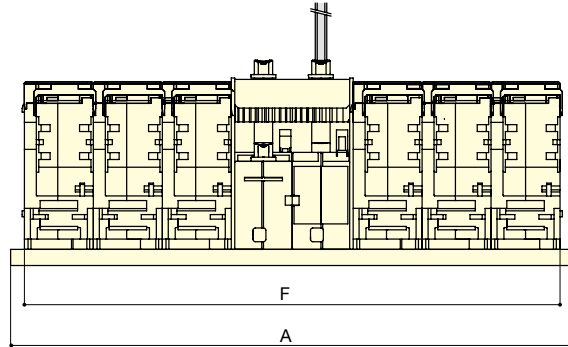

A. S1 handle: 50 and 63 A
 B. S2 handle: 100 to 400 A
 C. Door drilling

1. Fuse blown indication not available for BS88
 2. Terminal shrouds

Rating (A)	Fuse size	Frame size	Overall dimensions				Terminal shrouds	Switch body								Switch mounting		Connection							
			A 3p	A 4p	E min	E max		F 3 P	F 4 P	H	J 3 P	J 4 P	J1 3 P	J1 4 P	DA	DB	N	T	U	W	Y	Z	AA	BA	
50	14 x 51	11	264	318	100 ⁽¹⁾	146 ⁽¹⁾		121	148	87 ⁽¹⁾	102	129	138	165	85	153	90	27						118	
63	00C	12	294	358	125	145		136	168	116.5 ⁽²⁾	121	153	158	189	159	145	90	32						118	
100	22 x 58	13	318	390	135	145	268	148	184	116 ⁽²⁾	133	169	169	205	141	187	128	36	20	8.5	2.5	19.5	162	141	
125	22 x 58	13	318	390	135	145	268	148	184	116 ⁽²⁾	133	169	169	205	141	179	128	36	20	8.5	2.5	19.5	162	141	
125	00	13	318	390	135	145	268	148	184	126.5	133	169	169	205	141	193	128	36	20	8.5	2.5	19.5	162	141	
160	00	13	318	390	135	145	268	148	184	126.5	133	169	169	205	141	193	128	36	20	8.5	2.5	19.5	162	141	
160	0	14	402	502	145	225	268	190	240	136.5	176	226	212	262	174	229	128	50	20	8.5	2.5	19.5	162	141	
250	1	15	490	610	154	225	345	234	294	146	213	273	263	323	185	251	155	60	32	11	2.5	19.5	195	166	
400	2	16	526	658	157	225	355	252	318	149	231	297	281	347	200	260	168	66	50	11	3	20	205	175	

(1) 1 AC: +23.5 / 2 AC: +47
 (2) 132 with 2 AC

Direct operation

NFC CD 25 to CD 32 A in frame size 0 / fuse size 10 x 38

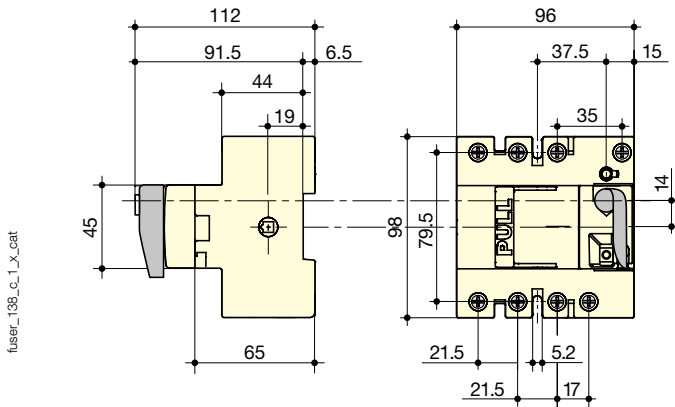

BS88 CD 20 to CD 32 A in frame size 0 / fuse size A1 - NFC CD 32 A in frame size 0 / fuse size 14 x 51

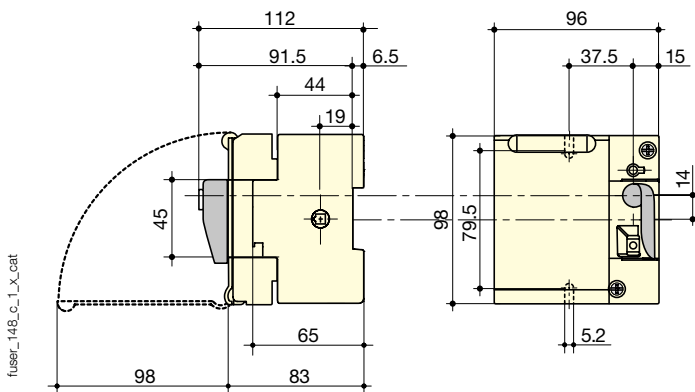

FUSERBLOC

Fuse combination switches

for industrial fuses up to 1250 A

Dimensions (continued)

Direct operation (continued)

BS88 32 to 400 A - NFC and DIN 50 to 400 A

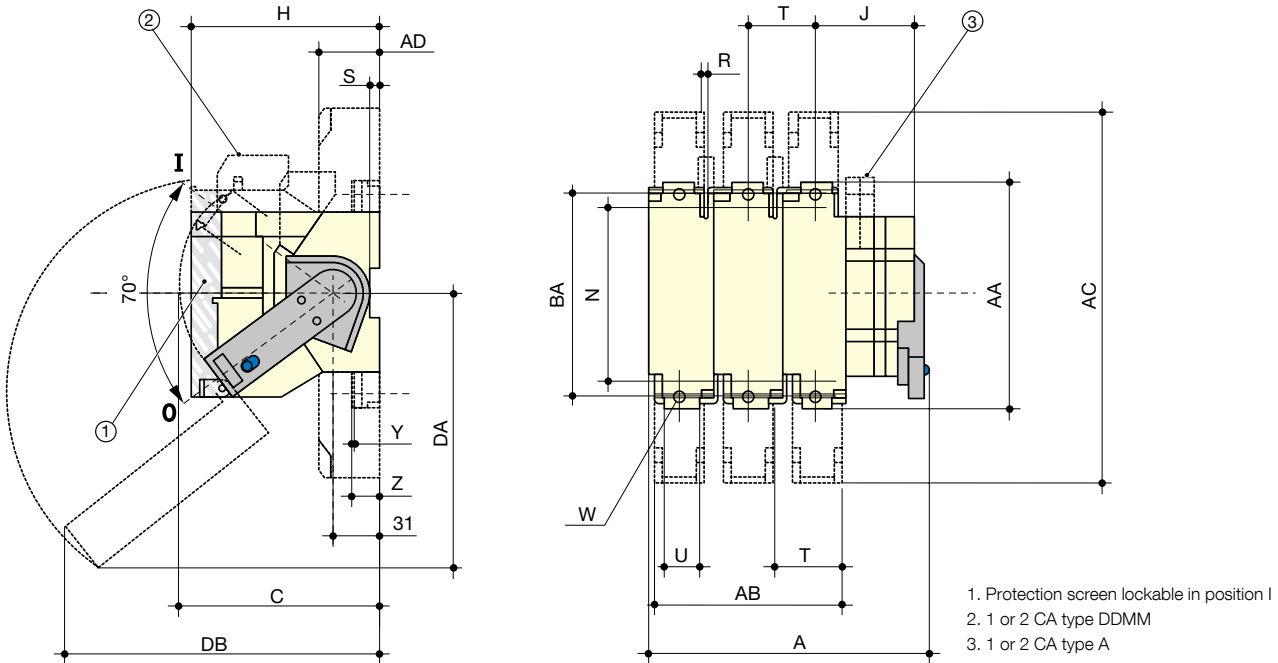

fuser_064_b_1_LX_cat

Rating (A)	NFC/DIN Fuse size	BS88 Fuse size	Frame size	Overall dimensions			Terminal shrouds				Switch body				Switch mounting			Connection						
				A 3p.	A 4p.	C	AB 3p.	AB 4p.	AC	AD	H	J	DA	DB	N	R	S	T	U	W	Y	Z	AA	BA
32	-	A1	1	118	145	134	-	-	-	-	87	33.5	-	-	106	5.4	6.5	27	-	-	-	-	118	-
50	14 x 51	-	1	118	145	134	-	-	-	-	87	33.5	-	-	106	5.4	6.5	27	-	-	-	-	118	-
63	00C	A2-A3	2	133	165	134	-	-	-	-	116	36	159	145	106	5.4	6.5	32	-	-	-	-	118	-
100	22 x 58	A4	3	150	186	173	108	144	268	44	116	38	-	-	127	5.4	-	36	20	8.5	2.5	19.5	162	141
125	22 x 58	-	3	150	186	173	108	144	268	44	116	38	-	-	127	5.4	-	36	20	8.5	2.5	19.5	162	141
125	00	-	3	150	186	173	108	144	268	44	126	38	141	193	127	5.4	-	36	20	8.5	2.5	19.5	162	141
160	00	-	3	150	186	173	108	144	268	44	126	38	141	189	127	5.4	-	36	20	8.5	2.5	19.5	162	141
CD 160	-	A3-A4	3A	152	188	173	108	144	268	44	139	38	-	-	130	5.4	-	36	20	8.5	3	19.5	162	141
160	-	A4	4	192	242	173	136	172	268	44	136	45	174	229	140	5.4	-	50	20	8.5	2.5	19.5	162	141
160	0	B1-B2	4	192	242	173	136	172	268	44	136	45	174	229	140	5.4	-	50	20	8.5	2.5	19.5	162	141
CD 200	-	A3-A4	3A	152	188	173	108	144	268	44	139	38	-	-	30	5.4	-	36	20	8.5	3	19.5	162	141
200	-	B1-B2	5	253	313	173	180	240	345	65	146	81	185	251	162	6.4	-	60	32	11	2.5	19.5	195	166
250	1	B1-B2-B3	5	253	313	173	180	240	345	65	146	81	185	251	162	6.4	-	60	32	11	2.5	19.5	195	166
315	-	B1-B2-B3	6	253	313	173	180	240	355	65	146	81	185	251	162	6.4	-	66	32	11	2.5	19.5	195	175
400	2	B1-B2-B3-B4	6	271	337	173	192	258	355	65	149	86	200	260	172	6.4	-	66	50	11	3	20	205	175

External and direct operation

BS88 630 to 800 A - DIN 630 to 1250 A

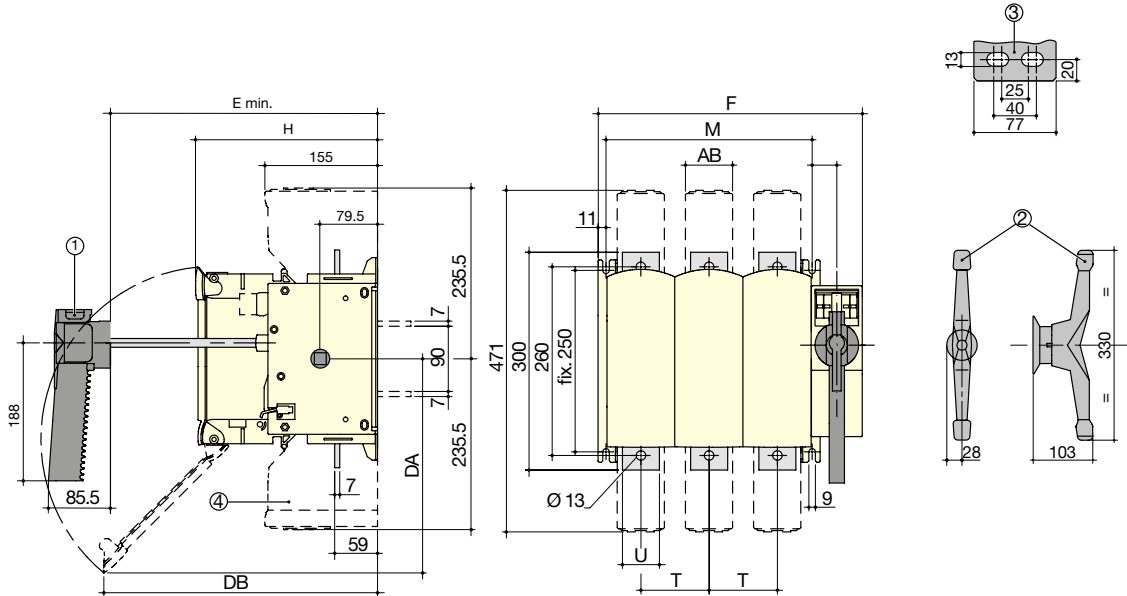

1. For handle frame size 17.
2. For handle frame size 18.
3. Connection terminals for frame size 18.
4. Terminal shrouds.

Rating (A)	DIN Fuse size	BS88 Fuse size	Frame size	Overall dimensions	Switch body					Switch mounting		Connection		Terminal shrouds
				E min	F 3p.	F 4p.	H	DA	DB	M 3p.	M 4p.	T	U	AB
630	3	C1-C2	17	265	364	458	250	300	380	284	378	94	51	65
800	3	C1-C2-C3	17	265	364	458	250	300	380	284	378	94	51	65
800	4	-	18	304	442	562	289	355	295	362	482	120	77	88
1250	4	D1	18	304	442	562	289	355	295	362	482	120	77	88

fuser_415_g_1_x_cat

FUSERBLOC

Fuse combination switches

for industrial fuses up to 1250 A

Dimensions for external operation handles

BS88 - 32 to 63 A - NFC and DIN - 25 to 63 A

Handle type	Front operation		Side operation	
	Direction of operation	Door drilling	Direction of operation	Door drilling
S1 type Box size 0 				

fuser_712_a_1_gb_cat

BS88 / NFC and DIN - 100 to 400 A

Handle type	Front operation		Side operation	
	Direction of operation	Door drilling	Direction of operation	Door drilling
S2 type Box size 11-16 				

fuser_713_a_1_gb_cat

BS88 / NFC and DIN - 630 to 800 A

Handle type	Front operation		Side operation	
	Direction of operation	Door drilling	Direction of operation	Door drilling
S3 type Box size 17 				

fuser_714_a_1_gb_cat

BS88 / NFC and DIN - 800 to 1250 A

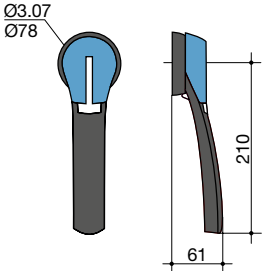
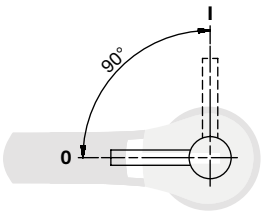
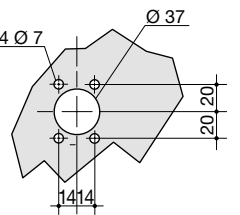
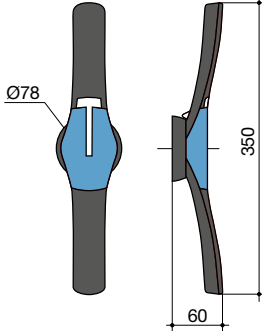
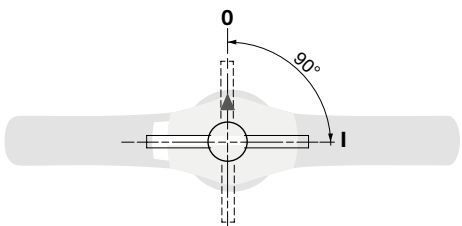
Handle type	Front operation Direction of operation	Side operation Direction of operation	Door drilling
<p>S3 type Box size 18</p> 			
<p>S4 type</p> 			

fuser_715_a_1_gb_cat